

Malmo peat area

The Malmo peat area (24 acres) is in Seattle. East 45th Street passes close to its southern border, and 25th Avenue N.E. is close to its western border (map, fig. 62). It lies at the north end of Union Bay, which is an arm of Lake Washington. Most of this peat (fig. 62) is either fibrous or a mixture of fibrous and woody peat. There is

some diatomite in hole 6. The area was drained in 1917, when the level of the lake was lowered about 7 feet (see Mercer Slough peat area on p. 69), and for many years it has been utilized as a nursery by Malmo Nurseries & Seed Stores, Inc. Most of this peat area was covered with fill dirt in 1954, preparatory to construction of a shopping center here.

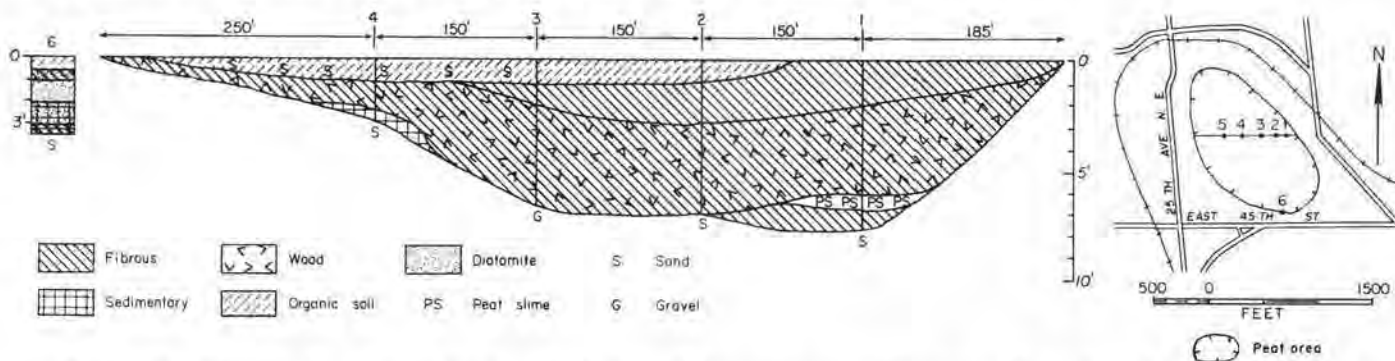

FIGURE 62.—Map, profile, and graphic log of a hole in Malmo peat area (24 acres). Map adapted from field sketch.

Paradise Lake peat area No. 1

The Paradise Lake peat area No. 1 (23 acres, of which 4 acres is sphagnum) is in sec. 5, T. 26 N., R. 6 E., about 7 miles east of Bothell, from which it is reached by paved roads and an improved gravel road. The lake and the peat lie in an undrained depression in the glacial drift of the plateau region. It is mapped as Rifle peat on the soil map of King County (Poulson et al., 1952).

disintegrated and watery. At the bottom of the layer near the lake it is decomposed. The fibrous peat is brown and varies from raw to disintegrated to decomposed. The sedimentary peat is gray green to olive brown and brown. The clay at the bottom of holes 1 and 2 is blue, and there is gravel at the bottom of hole 3. The layer of brown pumicite is half an inch thick. No evidence of any attempt at utilization was seen except a wire fence on the bog and the remains of an old log cabin near the woods at the margin.

The sphagnum bog (map, fig. 63) and a swamp forest occupy the area directly south of the lake. Some of the area at the west side of the lake has been cleared for use as a fishing resort.

Paradise Lake peat area No. 2 is north of the lake, in Snohomish County, so it is described on page 180 under that county heading.

The sphagnum found in the profile (fig. 63) is mostly

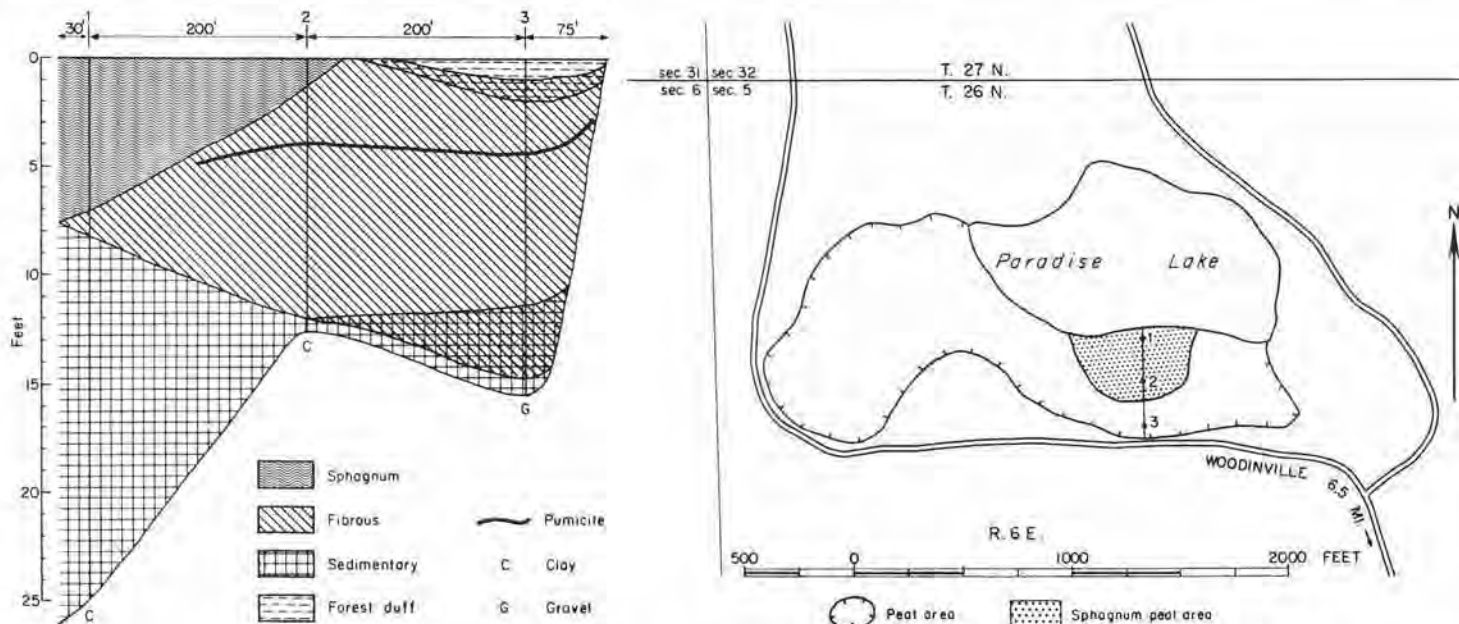

FIGURE 63.—Map and profile of Paradise Lake peat area No. 1, King County (23 acres, including 4 acres of sphagnum). Map adapted from U. S. Department of Agriculture soil map of King County.

Redmond peat area

The Redmond peat area (21 acres) is in sec. 7, T. 25 N., R. 6 E. It is about 1 mile east of Redmond, from which it is reached by State Highway 2 and a county road (map, fig. 64). It lies in an undrained depression in the glacial drift of the plateau region. It is mapped as Rifle peat on the soil map of King County (Poulson et al., 1952).

The north part of the peat area is mostly covered with hardhack, Labrador tea, ferns, sedges, and weeds.

Some of it has been burned. The south part is in cultivation (oats in 1951). When inspected by Rigg in 1926 the north part of this area was a typical sphagnum bog which showed evidence of having been burned a few years earlier. The south part was in oats.

The fibrous peat in this deposit (fig. 64) is brown and is decomposed near the surface but is merely disintegrated at deeper levels. The sedimentary peat is olive to olive brown. The layer of brown pumicite is $\frac{3}{4}$ to 1 inch thick.

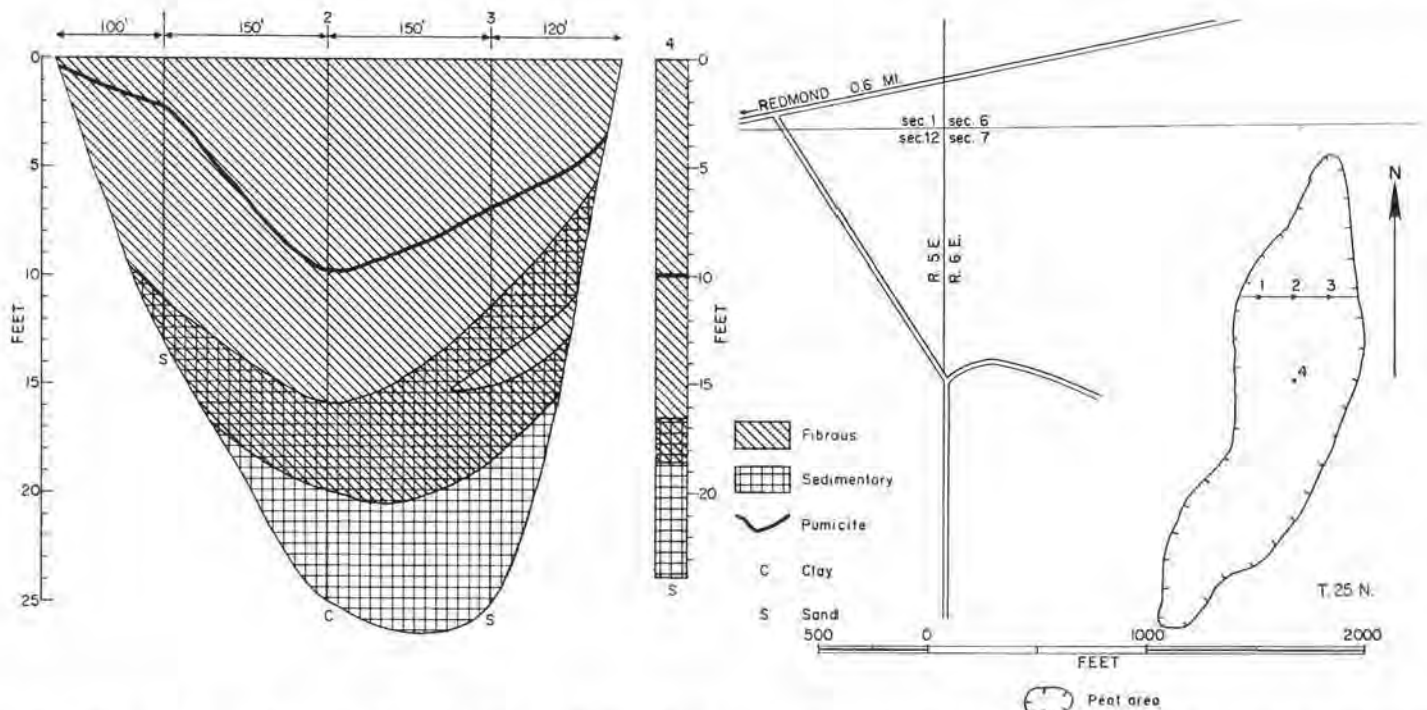

FIGURE 64.—Map, profile, and graphic log of a hole in Redmond peat area (21 acres). Map adapted from U. S. Department of Agriculture soil map of King County and U. S. Army Map Service photomosaic.

Black Diamond peat area

The Black Diamond peat area (18 acres) is in sec. 2, T. 21 N., R. 6 E., about 19 miles southeast of Renton, from which it is reached by State Highway 5. It is on the west side of the highway about $1\frac{1}{2}$ miles north of Black Diamond. It lies in a depression in the glacial drift of the plateau region. It is mapped as Greenwood peat on the soil map of King County (Poulson et al., 1952).

The map and profile (fig. 65) are redrawn from Rigg and Richardson (1938). This was partly a sphagnum bog and partly a sedge meadow, but several years prior to 1938 it was greatly modified by burning. No evidence of any attempt at utilization was evident in 1938.

Hansen (1941, 1947) shows 6.0 meters (19 feet 8 inches) of materials in his sedimentary column in this peat. This includes 4.0 meters (13 feet 1 inch) of fibrous peat, 1.0 meter (3 feet 3 inches) of limnic (sedimentary) peat, and 1.0 meter of silt. He shows volcanic ash (pumicite) in the fibrous peat at a depth of 2.0 meters (6 feet 7 inches) below the surface. A comparison of these data with the profile and the separate holes (fig. 65) indicates that his boring was not in the deepest part of the deposit.

Auburn Junction peat areas No. 1 and No. 2

Auburn Junction is the junction of U. S. Highway 410 (State Highway 5) with U. S. Highway 99 about 20 miles south of Seattle. Two peat areas are in sec. 16, T. 21 N., R. 4 E.

Area No. 1 (7 acres) is 100 feet east of Highway 99, and its northern border is about 300 feet south of highway 410. It is mostly covered with a dense growth of bracken fern, but there is a small pond in which water lilies and other aquatic herbs grow. Bracken ferns commonly form a dense and almost pure stand after a fire, and their presence here together with blackened trunks of small trees indicates complete burning a few years ago. There are some dry remains of *Sphagnum* among the ferns. The area is mapped as Greenwood peat on the soil map of King County (Poulson et al., 1952).

Most of the material in the profile (fig. 66) is olive-green to olive-brown sedimentary peat which is mixed with fibrous and woody peat near the surface. The peat at the 2-foot depth is rather strongly acidic (pH 4.5).

Area No. 2 (8 acres), which is about half a mile east of No. 1, is reached by a trail from Highway 410. It is a

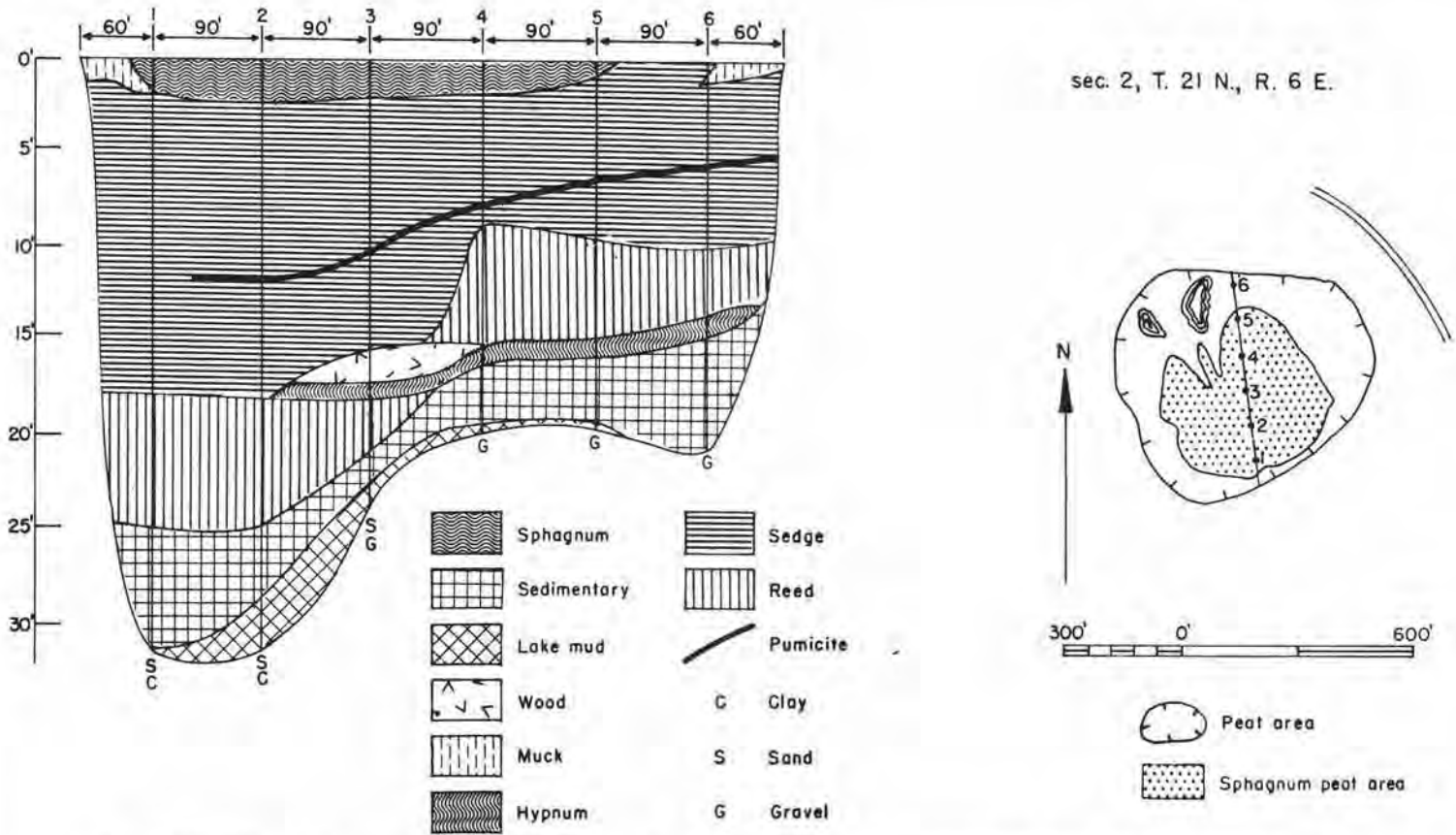

FIGURE 65.—Map and profile of Black Diamond peat area (18 acres). Map adapted from Rigg and Richardson (1938).

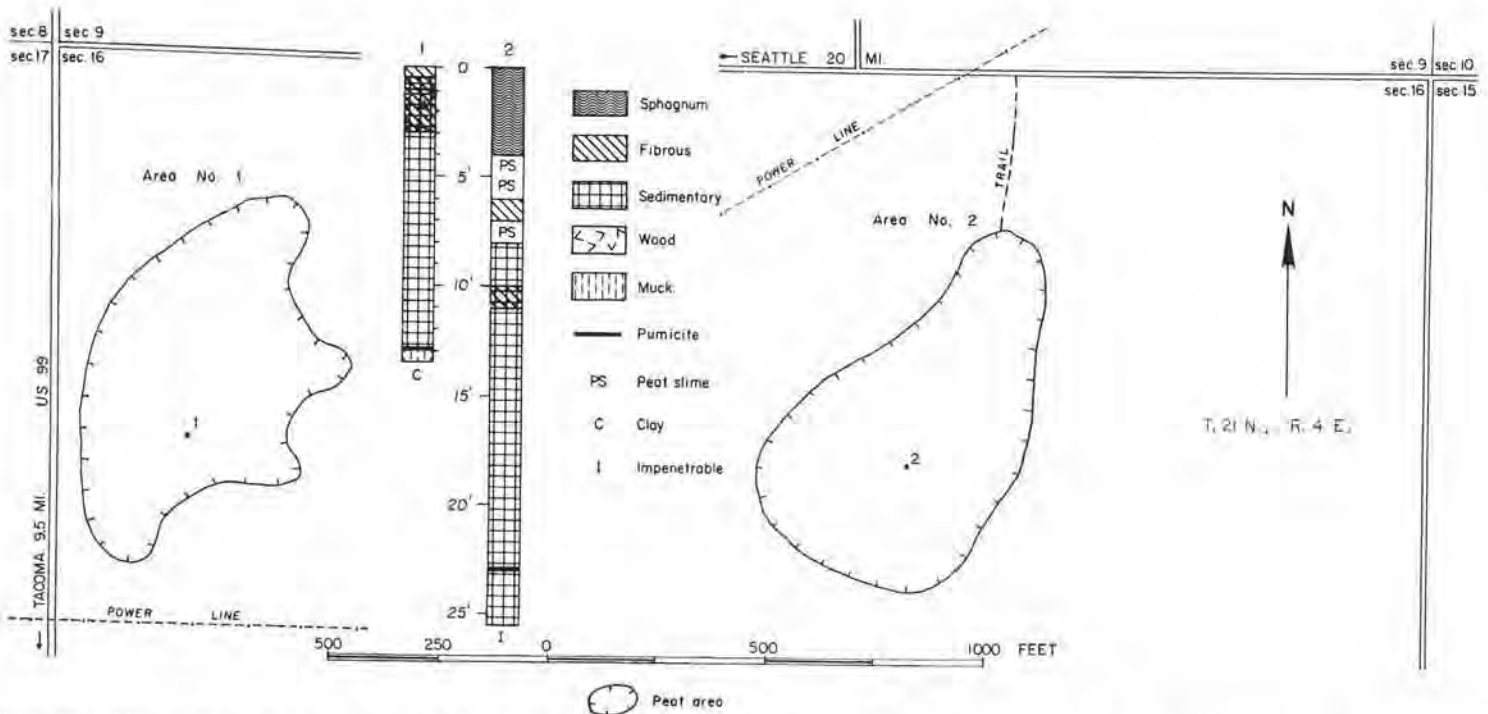

FIGURE 66.—Map and graphic logs of two holes in Auburn Junction peat areas (7 acres and 8 acres). Map adapted from U. S. Department of Agriculture soil map of King County and U. S. Army Map Service photomosaic.

sphagnum bog which is still in its natural condition. It is mostly covered with Labrador tea shrubs 1 to 2 feet tall, but in some wetter places there is a varied bog flora including herbaceous plants. The bog is practically treeless and thus presents a very open appearance. The few scattered trees present are mostly hemlocks, some of which are 25 feet tall. The area is mapped as Mukilteo peat on the soil map of King County (Poulson et al., 1952).

At the surface (fig. 66) the sphagnum is brown and raw, but at the 4-foot depth it is disintegrated and watery and has 2 feet of peat slime under it. The small amount of fibrous peat in the profile is brown, fine, and watery. The sedimentary peat is olive green to olive brown. At the depth of 25½ feet it is too compact to be penetrated farther with the peat borer. The mixture of fibrous and sedimentary peat at the 11-foot depth is rather strongly acidic (pH 4.5).

The layer of pumicite in these two peat areas indicates that both were in a very early stage of development when the ash fell. They may be compared with the Lakota peat deposit (fig. 59), which was in a comparatively late stage of development at the time of the fall. The layer of brown pumicite in area No. 1 is 1 inch thick.

No evidence of any attempts at utilization was seen in either of the Auburn Junction peat areas.

Federal Way peat area

The Federal Way peat area (14 acres) is in sec. 8, T. 21 N., R. 4 E., about 5 miles west of Auburn. It is on the Mirror Lake road and is about ¾ mile west of U. S. Highway 99, which is locally known as Federal Way (map, fig. 67). It is shown as Mukilteo peat on the soil map of King County (Poulson et al., 1952). The peat lies in an undrained depression in the glacial drift of the plateau

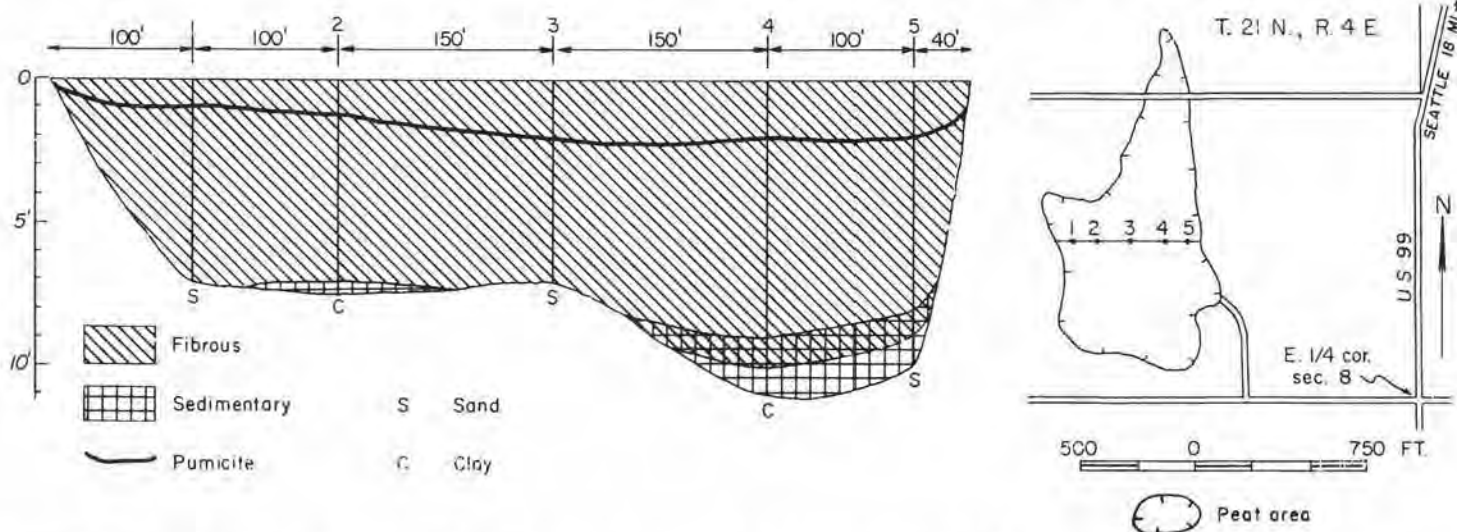

FIGURE 67.—Map and profile of Federal Way peat area (14 acres). Map adapted from U. S. Department of Agriculture soil map of King County and U. S. Army Map Service photomosaic.



FIGURE 68.—Loading peat, Federal Way Humus Company.

region. The vegetation has been removed to facilitate the removal of peat. Peat is being excavated by the use of power machinery and sold for agricultural use by the Federal Way Humus Company, P. O. Box 200, Auburn.

The peat revealed in the banks of the excavation and in the profile (fig. 67), which is in a part of the area from which no peat has been removed, is mostly fibrous. It is brown to dark brown and disintegrated to decomposed. At the 6-foot depth in hole 4 it is rather strongly acidic (pH 4.3). The layer of brown pumicite is 2 inches thick.

North Lake peat area

The North Lake peat area (13 acres) is in sec. 15, T. 21 N., R. 4 E., about 2 miles west of Auburn and about 1 mile east of U. S. Highway 99. The peat and the lake lie in a depression in the glacial drift of the plateau region. It is mapped as Greenwood peat on the soil map of King County (Poulson et al., 1952).

The peat area borders the north end of the lake (map, fig. 69) and merges into the marshy shore of the lake. The vegetation on the peat is mostly undisturbed and consists of low brush (hardhack and Labrador tea), small trees (crab apple and cascara), and small herbs and some mosses (not *Sphagnum*).

The peat (fig. 69) is mostly fibrous, either alone or mixed with sedimentary peat. It is brown to dark brown,

and most of it is disintegrated. The sedimentary peat is olive brown and is compact at the bottom. It rests on blue clay.

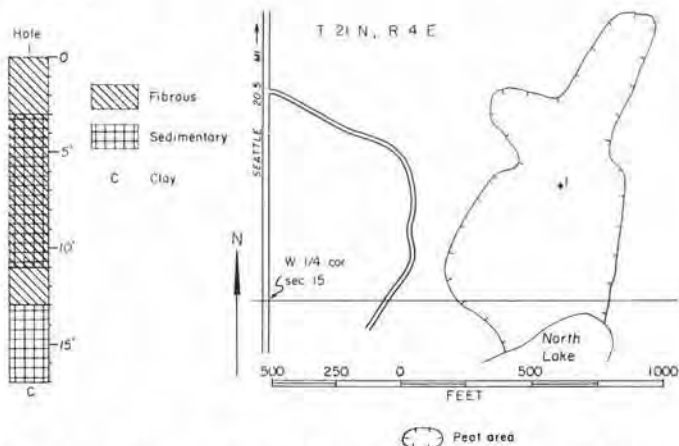

FIGURE 69.—Map and graphic log of a hole in North Lake peat area (13 acres). Map adapted from U. S. Department of Agriculture soil map of King County and U. S. Army Map Service photomosaic.

Seola peat area

The Seola peat area (12 acres) is south of the West Seattle district of the city of Seattle. The streets and avenues are numbered on the Seattle system. There is access to the peat by a private road which leads west from 28th Avenue S.W. near 104th Street S.W. (map, fig. 70).

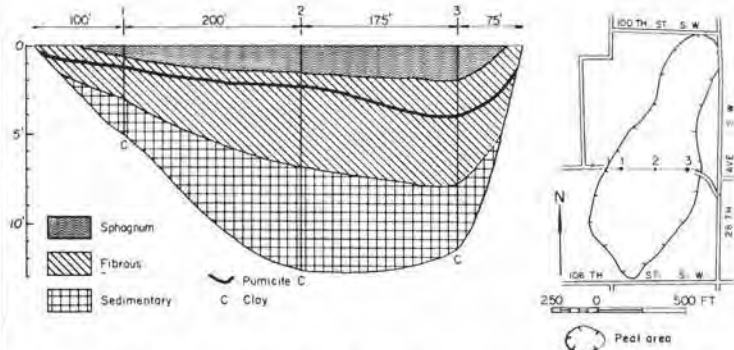

FIGURE 70.—Map and profile of Seola peat area (12 acres). Map adapted from U. S. Department of Agriculture soil map of King County and U. S. Army Map Service photomosaic.

Peat is being removed from the area by the use of power machinery and sold for agricultural use by the Seola Humus Company, 7335 34th Avenue S.W., Seattle. The sphagnum and the fibrous peat (fig. 70) are brown and mostly somewhat disintegrated, but some of the fibrous peat is slightly mixed with sedimentary peat, and this mixture is black. The sedimentary peat where it occurs alone is olive. It rests on blue clay. The layer of brown pumicite is 1 inch to 2 inches thick.

This peat area is a bog of mixed sedges and *Sphagnum* which in 1920 bore a growth of low bog shrubs and numerous scattered small coniferous trees. It has been greatly modified by the activities connected with the removal of peat.



FIGURE 71.—Part of bank of excavation in Seola peat deposit (28th Avenue S.W. and 104th Street S.W., Seattle). Layer of white diatomite, approximately 3 inches thick, 18 inches below surface. Layer of brown pumicite (dark color) below diatomite. Top and bottom of bank not shown.

Ames Lake peat area

The Ames Lake peat area (10 acres) is half a mile west of Ames Lake, in secs. 13 and 24, T. 25 N., R. 6 E., and secs. 18 and 19, T. 25 N., R. 7 E. This is about 9 miles southeast of Redmond, from which the area is reached by State Highway 2 and by a county road leading northeast from the highway to the vicinity of Ames Lake, and thence by an old logging road which ends a few hundred feet from the peat (map, fig. 72). A trail leads from the end of this road to the peat area. This peat lies at an elevation of about 300 feet above sea level in a depression in the glacial drift of the plateau region. It is mapped as Greenwood peat on the soil map of King County (Poulson et al., 1952).

This is a roughly circular sphagnum bog which is still in its natural condition and is surrounded by coniferous forest. In its center is a pond which is shown on the Sultan 30-minute quadrangle and the Carnation 7½-minute quadrangle. Water lilies and water shields grow in the margin of the pond. The zone of the bog bordering

Arrow Lake peat area

The Arrow Lake peat area (8 acres) is in sec. 6, T. 22 N., R. 4 E. The streets and avenues there are numbered on the Seattle system. The peat is just west of First Avenue South and is near 196th Street (map, fig. 73).

This was formerly a shallow lake (Mud Lake). The water was pumped out about 1940, and peat has been produced by the Arrow Lake Humus Company since that date. By 1952 a large part of the peat had been removed from about half of the area. There is some shallow water in the pit, and occasional pumping is necessary. The depression is a kettle in glacial drift.

Numerous Douglas fir logs which were buried in this peat have been removed. Some of them have been sawed into lumber which was used for building purposes and other uses in connection with the removal of the peat. Some of the logs were 30 inches in diameter, and the longest was 50 feet in length. Smaller pieces of wood are common in the peat, and there are some well-preserved Douglas fir cones. No stumps have been found, and all the logs had broken ends and showed the remains of limbs. It seems evident that the trees grew on the glacial drift bordering the lake and were broken by wind.

Some of the peat is being removed by a specially constructed scraper with grill sides, which operates by a cable and dumps into a hopper for loading into trucks. Some of it is put through a hammer mill. Most of the unexcavated area has been scalped to prepare it for the removal of peat. In areas which have not been scalped the the vegetation is composed mostly of rushes (*Juncus*) and fireweed.

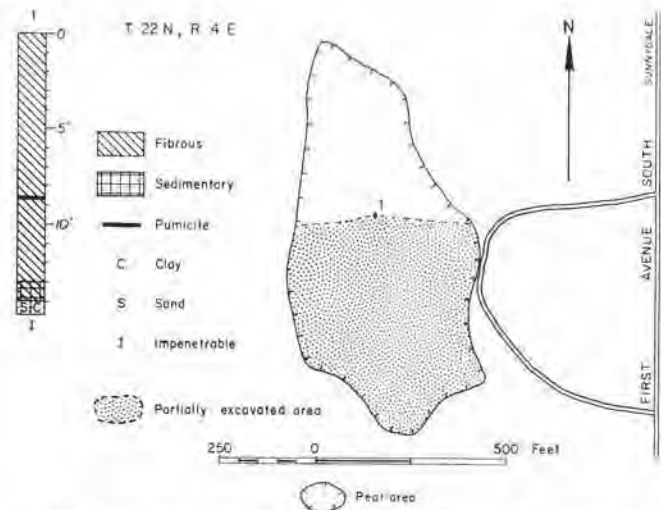

FIGURE 73.—Map and graphic log of a hole in Arrow Lake peat area (8 acres). Map adapted from U. S. Department of Agriculture soil map of King County and U. S. Army Map Service photomosaic.

The peat in this deposit is practically all fibrous (fig. 73), and the plant remains indicate that it originated from sedges. It is mostly disintegrated, but some coarse fibers still remain. Its color is brown. The mixture of fibrous and sedimentary peat is olive in color and is very compact. The mixture of sedimentary peat with sand and clay could not be penetrated by the borer beyond the depth of 14

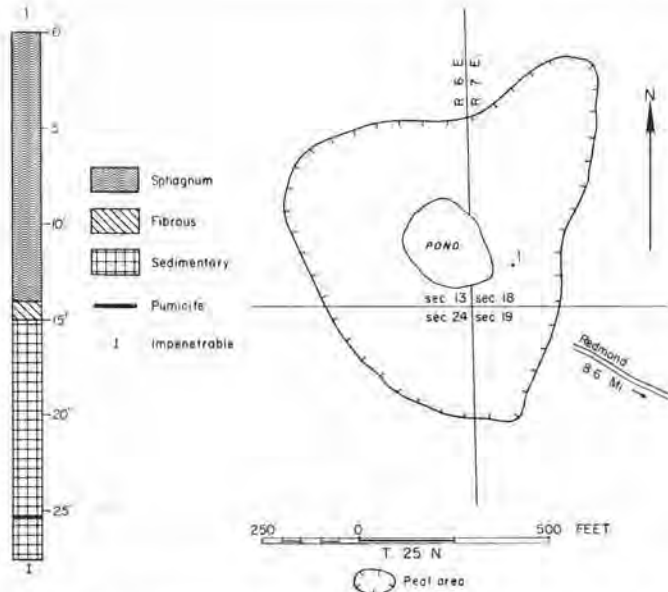

FIGURE 72.—Map and graphic log of a hole in Ames Lake peat area (10 acres). Map adapted from U. S. Department of Agriculture soil map of King County and U. S. Army Map Service photomosaic.

the lake is very wet and is covered with a growth of bog herbs, among which some small bog shrubs grow. Farther back from the pond the shrubs are somewhat taller and the herbs are less abundant. Young hemlock trees, many of them not more than 1 foot tall, grow on the bog.

The sphagnum peat (fig. 72) is unusually deep (14 feet) in the one hole that was bored. It is brown and watery, and changes gradually from raw at the surface to decomposed at the bottom of the layer. The fibrous peat is brown and watery and occurs in a layer only 1 foot thick. The sedimentary peat is olive, and at the 27½-foot depth it is too compact to be penetrated farther with the peat borer.

The position of the layer of pumicite (white, half an inch thick) in this peat indicates that only sedimentary peat had been deposited before the time of the ash fall and that afterward the deposition of sedimentary peat went on for a long time before the formation of fibrous peat and sphagnum peat began. In the Moss Lake peat, 6 miles northeast of Ames Lake, about 8 feet of sedimentary peat had accumulated up to the time of the ash fall, and in the Beaver Lake peat, 4 miles southwest of the Ames Lake peat, more than 20 feet of sedimentary peat had accumulated before that time. No ash was found in the Lake Joy peat, which probably indicates that peat formation there did not begin until after the time of the fall of ash.

This bog and the pond in it are good places for the study of aquatic and semiaquatic organisms, both plant and animal, which live under acid conditions. Such basic knowledge is important in planning for the best utilization of our resources in the future. This bog might well be preserved for scientific study.



FIGURE 74.—Old bank of peat excavation in Arrow Lake peat deposit.

feet 8 inches. The layer of pumicite is 2 inches thick. It is brown, but it weathers white where it is exposed in banks in the excavated area.

Webster Lake peat area

The Webster Lake peat area (estimated as 8 acres) is in sec. 34, T. 23 N., R. 6 E., about 2½ miles north of Maple Valley and about 8 miles southeast of Renton, from which it is reached by State Highway 5, a county road, and a private road. It is a sphagnum bog surrounding Webster Lake in a depression in the glacial drift of the plateau region. The peat is more than 10 feet deep, but no other data are available. It is mapped as Rifle peat on the soil map of King County (Poulson et al., 1952).

Bingaman Lake peat area

The Bingaman Lake peat area (7 acres) is in sec. 34, T. 22 N., R. 4 E., about 2 miles southwest of Kent. It is reached by county roads and an improved road which ends at the border of the peat. A pond in the center of the peat area (map, fig. 75) is drained by a small stream which flows northeastward to White River. On the soil map of King County (Poulson et al., 1952) the area is mapped as Greenwood peat.

This is a very wet bog, and the peat is 22 feet deep (fig. 75). The area is owned by three cranberry producers, who have a total of 4¼ acres in production. They control the level of the lake and thus flood the bog when necessary to protect against low temperatures. The cranberry bogs produce good crops in some years.

Carlson peat area

The Carlson peat area (about 7 acres) is in sec. 16, T. 25 N., R. 6 E., about half a mile north of the Happy Valley peat. It is in a kettle in the plateau region and is reached by a steep crooked road from State Highway 2. It is a practically treeless sphagnum bog surrounded by a zone of hardwood. On the soil map of King County (Poulson et al., 1952) it is mapped as Greenwood peat with some Rifle peat on the south side.

The mixture of decomposed sphagnum peat and fibrous

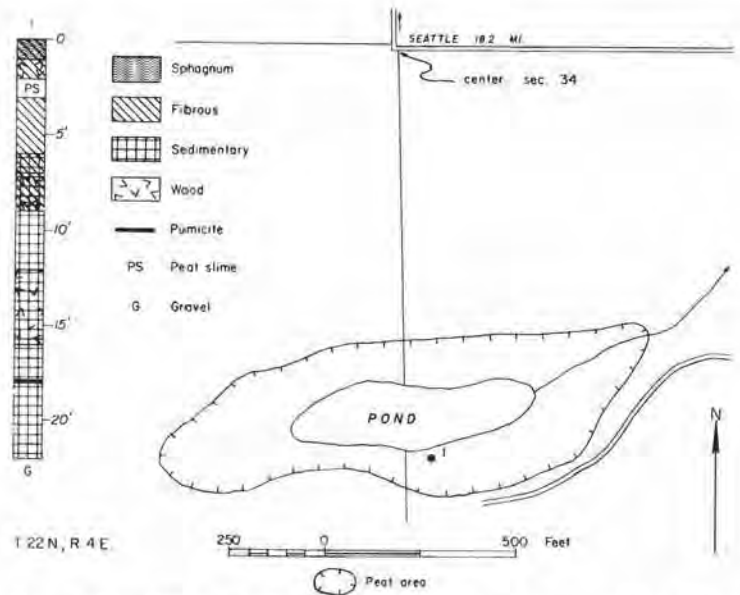

FIGURE 75.—Map and graphic log of a hole in Bingaman Lake peat area (7 acres). Map adapted from U. S. Department of Agriculture soil map of King County and U. S. Army Map Service photomosaic.

peat at the surface (fig. 41) is dark brown. The fibrous peat immediately under it is also decomposed, but at deeper levels it is merely disintegrated. The mixture of fibrous peat and sedimentary peat extending from the 9-foot to the 17½-foot level is olive brown. The peat in this deposit is rather strongly acidic even at the bottom. The pH of the watery fibrous peat at the 7-foot depth is 4.3, and that of the mixture of fibrous and sedimentary peat at 17 feet is 4.9. The layer of brown pumicite is 2 inches thick.

In 1950 peat was being removed from this bog and sold by the truckload for agricultural purposes by Eric E. Carlson, Route 1, Box 173, Redmond.

Lake Joy peat area

The Lake Joy peat area (6 acres) is in secs. 26 and 35, T. 26 N., R. 7 E. It is about 5 airline miles southeast of Duvall, from which it is reached by State Highway 15B and a county road leading up the hill from this highway at Stillwater. The peat borders the north arm of Lake Joy (map, fig. 76), which lies in a depression in the glacial drift of the plateau region. It is about 1 mile west of the Moss Lake peat.

It is shown as Rifle peat on the soil map of King County (Poulson et al., 1952). On this map are also shown an area of perhaps 10 acres of Rifle peat bordering the west shore of the lake and another of similar size bordering the southeast shore. These were not examined.

The Lake Joy peat area is a sphagnum bog with the usual bog shrubs, including the small woody vines of the native cranberry. Pigeon wheat moss grows with the *Sphagnum* on the surface. There are some scattered small hemlock and spruce trees on the bog.

The sphagnum (fig. 76) is brown. The fibrous peat is brown, and it varies from disintegrated to decomposed.

It is mixed with woody peat at two levels. The sedimentary peat is olive brown. It rests on blue clay.

The surface peat to a depth of about 2 feet has been removed from an area about 10 feet square.

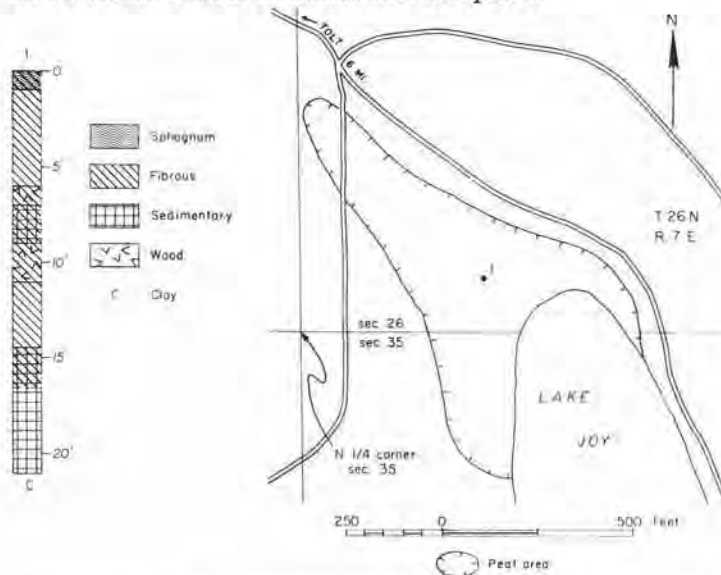

FIGURE 76.—Map and graphic log of a hole in Lake Joy peat area (6 acres). Map adapted from U. S. Department of Agriculture soil map of King County.

Echo Lake peat area

The Echo Lake peat area (5 acres) is in sec. 6, T. 26 N., R. 4 E., about 6 miles north of the north city limits of Seattle and about half a mile south of the northern boundary of King County. The extreme northeast end of the peat area is buried under U. S. Highway 99. The bog is about a quarter of a mile southwest of Echo Lake, and there was some drainage in winter from the peat area into the lake before the construction of the highway.

In 1923 this was a sphagnum bog in which Labrador tea was the dominant shrub. There were also some other bog shrubs, but very few herbaceous species. There was a natural broad swampy brushy marginal ditch. There were practically no trees on the bog.

In 1952 the northern part of the area was in use as a

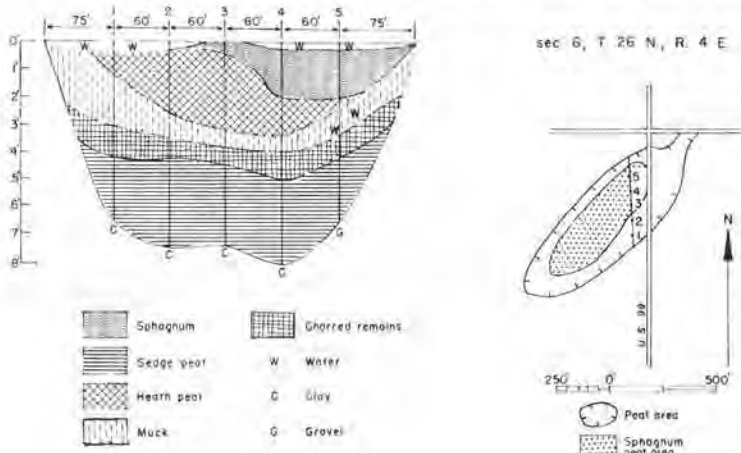

FIGURE 77.—Map and profile of Echo Lake peat area (5 acres). Map adapted from Rigg and Richardson (1938).

nursery, and the area of utilization had been recently extended.

The map and profile (fig. 77) have been redrawn from Rigg and Richardson (1938).

Formerly there was a small sphagnum bog bordering the north end of Echo Lake, but this was mostly buried several years ago by regrading when the property was improved.

Misner Farm peat area

The Misner Farm peat area (3½ acres) is in sec. 15, T. 21 N., R. 4 E., about 2 miles west of Auburn. It is less than 1 mile east of the North Lake peat area. A county road passes close to its east border (map, fig. 78). The peat lies on the glacial drift of the plateau region.

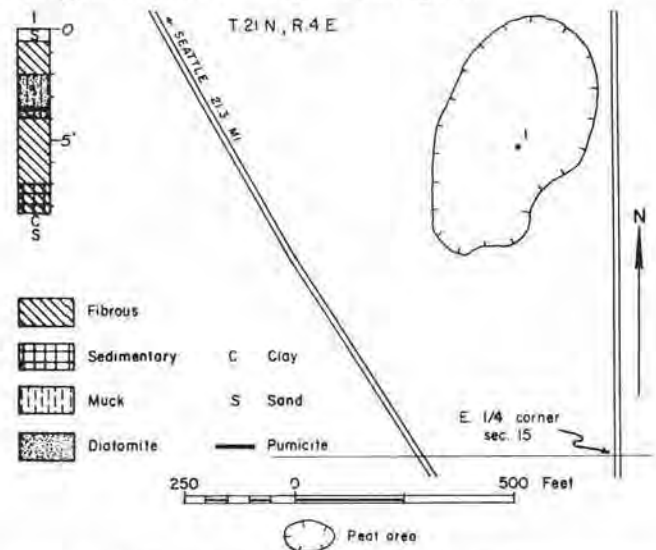

FIGURE 78.—Map and graphic log of a hole in Misner Farm peat area (3½ acres). Map adapted from U. S. Department of Agriculture soil map of King County and U. S. Army Map Service photomosaic.

There is an old commercial cranberry bog (1 acre) on this peat, on which the vines are still growing and producing berries. When examined in 1950 it was somewhat overrun by sedges, willows, and hardhack. The fibrous peat (fig. 78) is dark brown and is disintegrated to decomposed. The diatomaceous muck is brown. The layer of brown pumicite is 2 inches thick. The mixture of fibrous and sedimentary peat is olive. It rests on gray clay and sand.

Meridian peat area

The Meridian peat area (3½ acres) is in lot 1, block 1, Green Lake 5-acre tracts, near the intersection of Meridian Avenue and North 165th Street. It is north of the city limits of Seattle, but the avenues are named and the streets numbered on the Seattle system. There is some drainage to this area from the Ronald peat area.

This is a sphagnum bog with the usual flora of bog shrubs. It has been somewhat modified by the removal of the surrounding forest and the grading of a street near the east border of the area.

Three holes bored in the central part of the area in January 1953 vary from 23 to 25 feet in depth. They show

sphagnum peat, fibrous peat, woody peat, and sedimentary peat. The layers of peat are essentially the same in all three holes, varying only in thickness from hole to hole. The top layer is sphagnum from 4 to 5 feet thick. Under this is 1 foot of mixed sphagnum and fibrous peat, then 2 to 3½ feet of fibrous peat, 1 to 2 feet of mixed fibrous and sedimentary peat, and then 14 to 14½ feet of sedimentary peat. The sphagnum is brown and is raw at the top and disintegrated at the bottom. The sedge peat is brown and is slightly disintegrated. Woody peat occurs only as mixtures with other kinds of peat, occurring at the 7- to 8-foot depth in hole 2 and the 4- to 5-foot and the 13- to 14-foot depths in hole 3. The sedimentary peat is olive brown. It is wet at the top but is extremely dry and compact at the bottom. In hole 3 it is too compact to be penetrated with the peat borer beyond the 25-foot depth. The blue clay at the bottom of holes 1 and 2 is soft. White pumicite at a depth of from 20 to 24½ feet forms a layer 1 to 2 inches thick.

Some peat was removed and marketed by the former owner, W. E. Weaver, 165th Street and Meridian Avenue, Seattle. This area was acquired by the City of Seattle in 1953 to form part of the site of a station of Seattle City Light.

Lake Leota peat area

The Lake Leota peat area (2½ acres) is in secs. 11 and 12, T. 26 N., R. 5 E., about 4 miles east of Bothell. State Highway 2C (Woodinville to Duvall) passes about 200 feet north of the peat, which borders the north shore of Lake Leota (map, fig. 79).

The Lake Leota peat area (2½ acres) is in secs. 11 and 12, T. 26 N., R. 5 E., about 4 miles east of Bothell. State Highway 2C (Woodinville to Duvall) passes about 200 feet north of the peat, which borders the north shore of Lake Leota (map, fig. 79).

There is some drainage in winter from the east end of the lake to Daniels Creek, which flows into Cottage Lake Creek. This drainage has been somewhat increased by a ditch.

This area is a sphagnum bog with the usual flora of bog herbs, shrubs, and small coniferous trees, and the usual aquatic herbs where the bog borders the lake. The margin of the bog was somewhat disturbed a few years ago by the installation of a float for bathing, but the float has now been abandoned.

This small bog has a complicated structure (fig. 79).

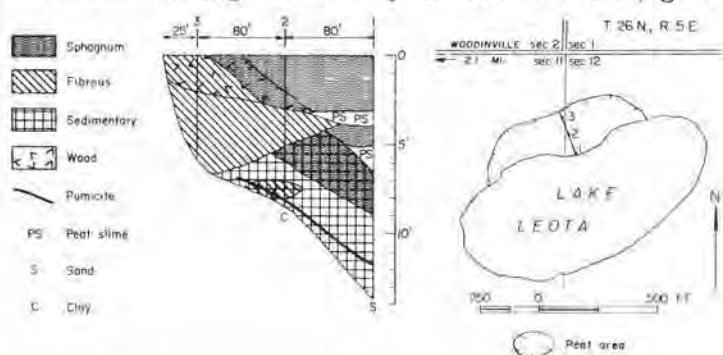

FIGURE 79.—Map and profile of Lake Leota peat area (2½ acres).
Map adapted from U. S. Army Map Service photomosaic.

There are six different kinds of material in it, and some of the layers of these materials are not continuous. The sphagnum is of good quality, but the amount of it is small.

An unpublished manuscript by G. W. Dorfmeier gives details of the flora of this bog, information about the layers of peat, and a list of the genera of the diatoms present in it. The diatoms were identified by Mr. and Mrs. H. E. Sovereign. A deposit consisting of a mixture of diatomite and organic matter 1 foot thick and 45 feet in width occurs close to the surface in the sedge peat near the marginal ditch at the north side of the bog. The 14 genera of diatoms present in this deposit are: *Amphora*, *Anomoioneis*, *Cymbella*, *Diploneis*, *Eunotia*, *Fragilaria*, *Gomphonema*, *Melosira*, *Navicula*, *Neidium*, *Nitzschia*, *Pinnularia*, *Surirella*, and *Tabellaria*. All these are also found scattered in the peat at various depths, some of them at the very bottom. They are, however, extremely scarce in the sphagnum layer.

There is considerable organic matter mixed with the diatomite. The percent of mineral matter in the dried material is 59.58, and this is probably composed mostly of the siliceous remains of diatoms. The pumicite (brown, 1 inch thick) in this bog was examined by J. D. Barksdale. He found that the glass is dacitic in composition, with an index of refraction of 1.500 to 1.505.

Some vegetables are grown on the muck at the border of the peat, but the lake level is too high to permit extension of cultivation.

Small peat areas in Seattle

In addition to the ones described individually (Ravenna and Malmo) there are also remains of a few other small peat areas in Seattle. At some of them dirt has been dumped on the peat and small dwellings have been erected. A permanent commercial building has been erected on one. This structure rests on piling driven through the peat (19 feet deep) into the clay and sand beneath.

KITSAP COUNTY DEPOSITS

Nettleton peat area

The Nettleton peat area (137 acres) is in secs. 23, 24, and 26, T. 24 N., R. 2 W., about 12 miles west of Bremerton. It is about 2 miles southwest of Crosby and about 4 miles southeast of Holly, which is on the shore of a small harbor (Anderson Cove) on Hood Canal. There are county roads within a quarter of a mile of the western and northern borders of the peat. Old logging roads, some of which are overgrown by young trees, extend to the steep slopes leading down to the peat.

The area is shown as Greenwood peat on the soil map of Kitsap County (Wildermuth et al., 1939), and as marsh on the Holly quadrangle. It is over 1 mile long and averages about 800 feet in width. It occupies an elongated depression in glacial drift. Big Beef Creek, which flows northeastward to Hood Canal, originates in the vicinity of the north end of this peat. The southern end of the peat area is drained by Tahuya Creek southwestward to Hood Canal.

This is a sphagnum bog with the usual flora of bog shrubs, 1 to 2 feet or more in height, and also the small

creeping woody vines of the native cranberry. There are some bog herbs. The bog was burned some years ago, and the shrubs and small lodgepole pine trees on much of it were killed. The shrubs (Labrador tea and bog laurel) have regenerated from stems and roots which survived the fire, and young lodgepole pine trees, 1 to 6 feet or more in height, have grown since the fire.

Sphagnum moss, both in flat patches and hummocks, is growing on fairly large areas, but in other places there is no living *Sphagnum* at all. In some places there is good sphagnum peat, 1 to 2 feet thick, and in others there is none. It seems probable that much of the sphagnum moss was destroyed in the fire.

This bog has been visited three times (April 1946; July 27, 1949; and June 30, 1950), but a complete profile of it has not been made. In 1946, when the north and central parts were examined, there was no standing water on this bog except a few shallow pools here and there. Borings made near the center of the bog showed 22½ feet of peat. It is mostly brown fibrous peat, which is mixed with sedimentary peat near the bottom. In 1949 the southern part was inspected. The growth of Labrador tea was very dense, there was no standing water, and the surface was firm enough to furnish good footing. When the north end was again visited in 1950, it was flooded to a depth of more than 3 feet. The average annual precipitation at Bremerton over a period of 40 years is 37.45 inches.

It is possible that the layer of peat moss (sphagnum) may be thicker in some other places than it is in the part that has been bored, and it is evident that the quantity of fibrous peat in the deposit is large. More borings should be made before incurring the expense of building a road into the bog. The drainage should also be investigated.

West of Nettleton peat area

This is a sphagnum bog about half a mile west of the Nettleton bog and in general similar to it. In August 1950 it was flooded but could be entered by men in hip boots. However, the water was too deep to permit convenient boring of the peat. This area is shown as Greenwood peat on the soil map of Kitsap County (Wildermuth et al., 1939). Its area is roughly estimated at 100 acres.

Other peat areas near Nettleton

Eight other smaller areas of Greenwood peat in this part of Kitsap County are shown on the soil map (Wildermuth et al., 1939). A small one lies just north of the Nettleton bog. Seven others lie to the east and southeast. The area of the largest of these is roughly estimated as 50 acres, and the total area of the other six is probably 80 acres or more. Further investigation would be necessary to determine whether they contain enough peat moss (sphagnum) and/or fibrous peat to justify development.

Carpenter Lake peat area

The Carpenter Lake peat area (102 acres) is in secs. 26 and 27, T. 27 N., R. 2 E., about 1 mile northwest of Kingston. Carpenter Lake lies in the peat area. A stream flows across the peat into the lake and across the peat again from the lake's outlet (map, fig. 80). Most of the peat area is mapped as Rifle peat on the soil map of Kitsap County (Wildermuth et al., 1939), but the peat bordering the lake is mapped as Greenwood. The peat lies in a region of glacial drift.

The part of the peat area lying east and south of the lake was examined. The sphagnum bog has the usual bog

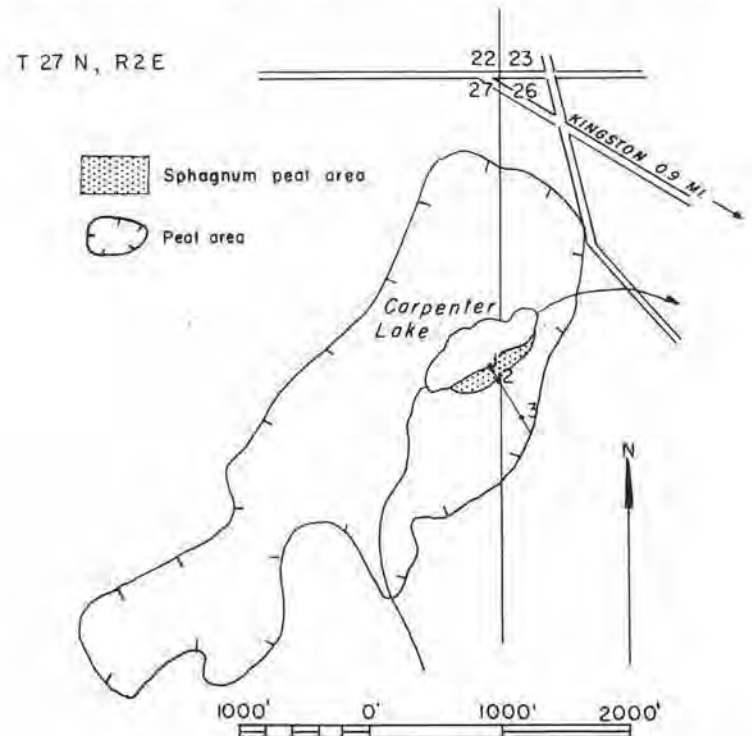
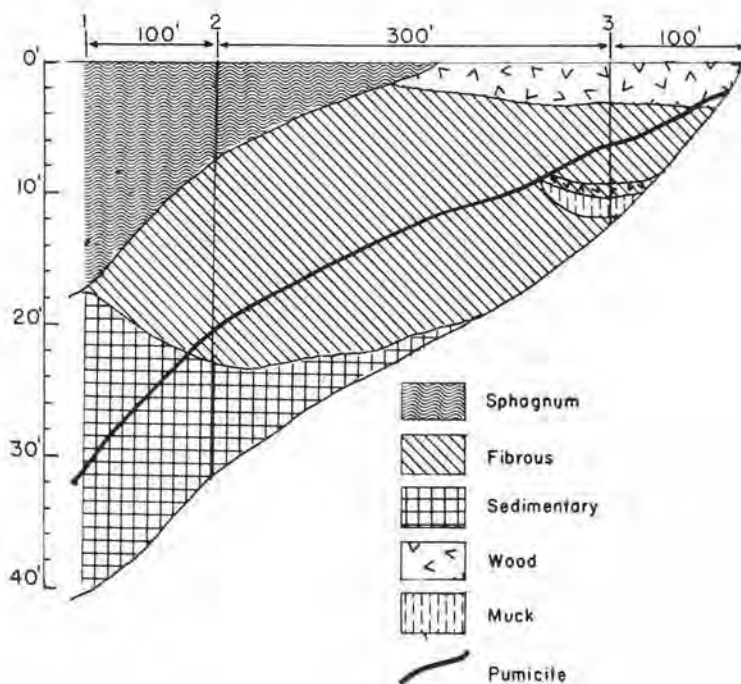

FIGURE 80.—Map and profile of Carpenter Lake peat area (102 acres). Map adapted from U. S. Department of Agriculture soil map of Kitsap County.

vegetation, and there is swamp and aquatic vegetation between it and the margin of the lake. The area from the border of the sphagnum bog to the border of the peat area is mostly wooded with willow and alder, but there are some open swampy places. The average annual precipitation at Keyport over a period of 23 years is 34.55 inches.

The sphagnum peat in hole 1 (fig. 80) down to the 9-foot depth is brown, raw, and of good quality. Below that, down to 17 feet, it is disintegrated and watery. In hole 2 it is similar, but the total depth is only 7 feet and it is dark brown toward the bottom. The fibrous peat is light brown to dark brown and disintegrated to decomposed. Some of it is watery and some contains wood peat and coniferous needles. The wood peat is raw and brown. The layer of white pumicite is 1 inch thick.

The water of the lake is strongly acidic (pH 3.8). The peat near the surface is also strongly acidic (pH 3.5), but at deeper levels the acidity is somewhat less (pH 4.5 to 5.0).

Some of the peat near the north end of the area is utilized for the production of vegetables.

Tahuya Lake peat area

The Tahuya Lake peat area (73 acres) lies in secs. 17 and 20, T. 24 N., R. 1 W., about 11 miles by road west of Bremerton and a little over 1 mile southeast of Crosby. It surrounds Tahuya Lake (map, fig. 81). The Tahuya River flows across the peat into the north end of the lake, then out of the south end of the lake, flowing lengthwise of the southeast arm of the peat and into Hood Canal. The river is a comparatively small stream where it flows over

the peat, but farther south in Mason County it receives a number of tributaries and carries a much larger volume of water.

The lake and the peat lie in a depression in a hilly region of glacial drift, but bedrock crops out along the river just south of the peat area.

About 25 acres of this peat area is sphagnum bog. This is in three separate areas, all bordering the lake. There is an area of about 15 acres at the southwest corner of the lake, one of about 5 acres on the east side, and one of about 5 acres near the north end. The remaining 48 acres is composed of wet sedge meadow, wet alder thicket, and wet areas covered with spiraea, sweet gale, and hardhack brush. The entire peat area is shown as alluvial soils on the soil map of King County (Wildermuth et al., 1939).

The sphagnum found in the profile (fig. 81) and in hole 7 varies from 3 to 6 feet in depth. It consists of whole stems with leaves still attached and is brown in color. The layer of sphagnum under this in the profile is somewhat disintegrated and is mixed with the remains of sedges and other fibrous plants. The fibrous peat is brown and varies from disintegrated to decomposed, and some is watery. Some of it is slightly mixed with leaves and small roots, and some has a felty character. A trace of pumicite was found in only one hole (hole 3).

Good peat moss (sphagnum) was produced for several years from the area which borders the southwest corner of the lake by J. M. Hoar of Bremerton. The peat was excavated by hand in the form of sods, dried in the open during the summer, and transported to a large building for storage. Handcars on rails were used for transportation. The building provided ample storage space and

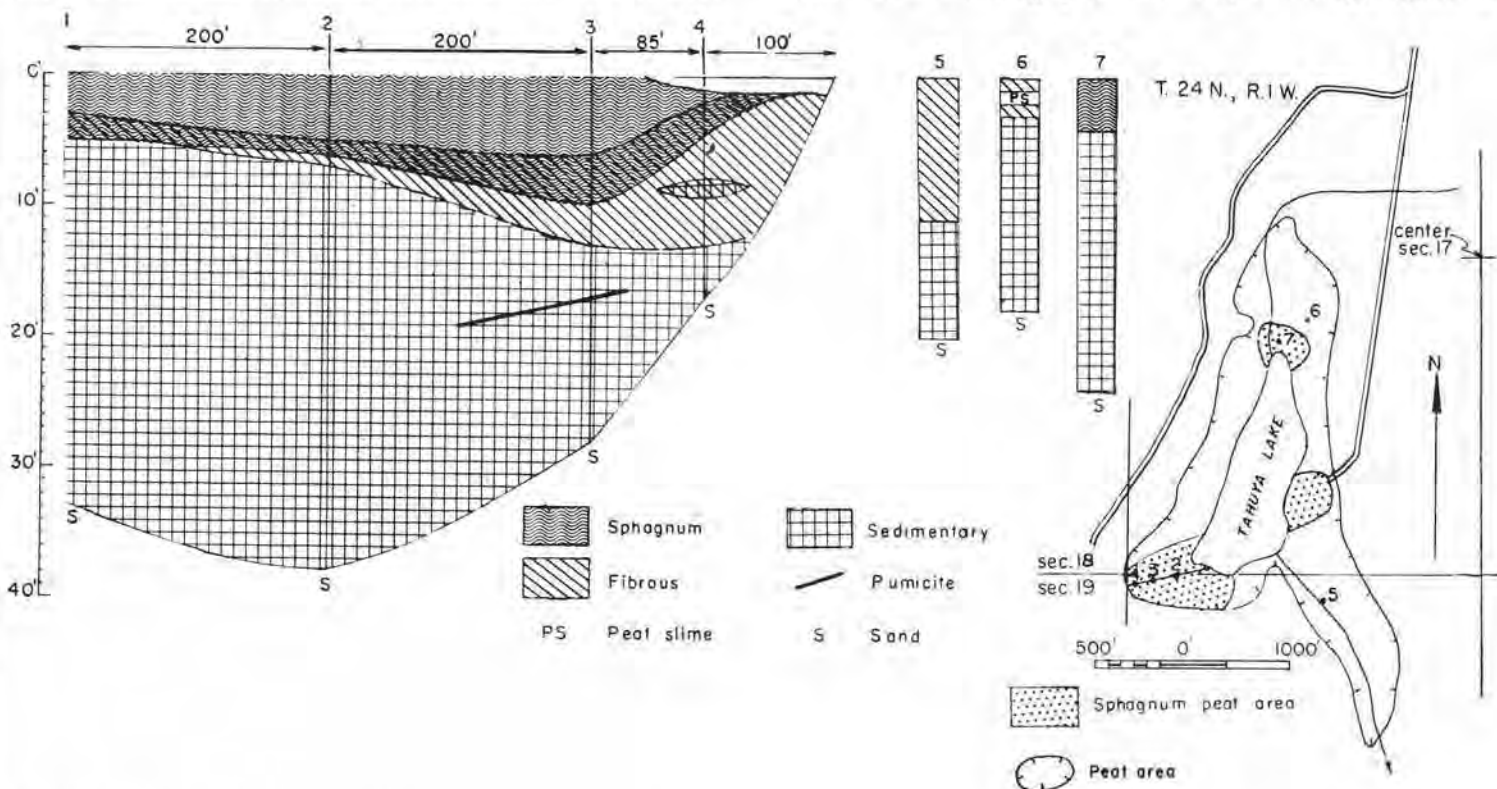

FIGURE 81.—Map, profile, and graphic logs of three holes in Tahuya Lake peat area (73 acres). Map adapted from U. S. Army Map Service photomosaic.



FIGURE 82.—Bales of peat moss on truck and loading platform, Tahuya Lake peat deposit.



FIGURE 83.—General view of Tahuya Lake peat deposit, showing excavated areas.



FIGURE 84.—Near view of excavated area in sphagnum peat, Tahuya Lake peat deposit.



FIGURE 85.—Hauling excavated blocks of sphagnum moss from bog to storage shed on handcar, Tahuya Lake peat deposit.

also contained machinery for shredding and baling. Some of the moss was placed in special paper sacks holding three-fourths of a cubic foot. The baled or sacked material was marketed in Seattle. During the severe winter of 1949-50 the building collapsed under the heavy weight of snow, and production was discontinued. In 1950 good peat moss was being excavated by hand from the 5-acre area near the east shore of the lake by Mr. Hoar.

The production and marketing of peat moss from the Tahuya Lake area has been one of the largest and most continuous of such operations in the state. The size of the sphagnum areas and the good quality of the moss are favorable for continued production.

Fibrous peat has been removed with mechanical equipment from the southeast arm of the peat area by the Lake Tahuya Humus Company (C. A. Turner, owner) of Bremerton for several years. It is sold mostly by the truckload or on larger contracts in Bremerton and vicinity. The fact that this peat has been marketed in the same vicinity for several years indicates its good quality.

Port Madison Indian Reservation peat area

This peat area (estimated 60 acres) on the Port Madison Indian Reservation is in secs. 18 and 19, T. 26 N., R. 2 E., about 3 miles by road west of Suquamish. Water flows from a large pipe buried in the peat into a stream which flows into Agate Passage. The peat area is elongated north

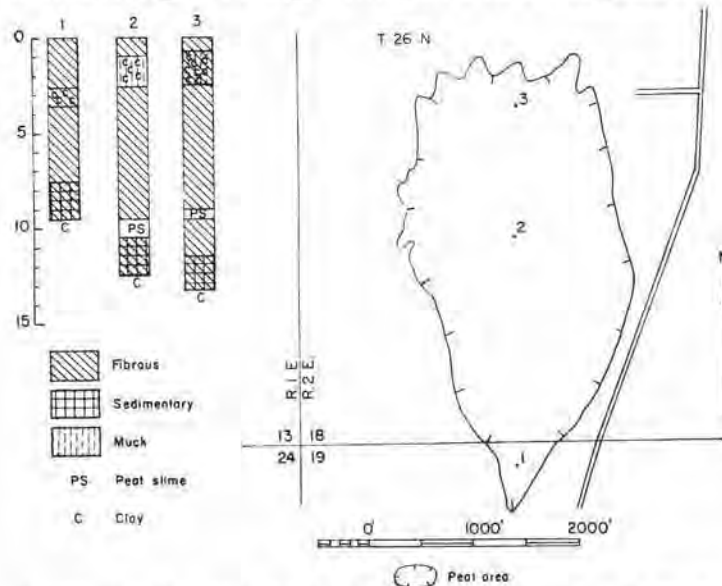

FIGURE 86.—Map and graphic logs of three holes in Port Madison Indian Reservation peat area (60 acres, estimated). Map adapted from U. S. Department of Agriculture soil map of Kitsap County.

and south, having an extreme length of about $\frac{3}{4}$ mile and an extreme width of about 1,800 feet. On the soil map of Kitsap County (Wildermuth et al., 1939) this area is mapped as Greenwood peat with a strip of Rifle peat on the north and east borders.

A sphagnum bog occupies the central and north central parts of this area. A robust species of *Sphagnum* covers the surface and also forms some hummocks. The shrubs here are Labrador tea and bog laurel, and there are also some native cranberry vines. The principal species on

the extreme northern part of the bog is a reed (*Juncus*). The southern part of the area is covered with a dense growth of hardhack with some patches of slender species of *Sphagnum* growing on the surface among the shrubs. A little farther north, Labrador tea and some bog laurel grow with the hardhack. There are also some grassy areas in which the bog shrubs are small and scattered. Very few trees grow on this peat area, although there are a few small white pine trees in some places.

Three holes (fig. 86) show a progressive decrease in the depth of the peat from north to south. The most abundant material is brown fibrous peat. The upper part of this is mixed with fine roots, but the lower part is of good quality. Some clay and muck occur near the surface.

Some peat was removed from the eastern part of this bog and marketed locally in 1950. When this peat was being excavated, a layer of diatomite 8 to 14 inches thick was encountered at a depth of 2 to 3 feet.

Suquamish sphagnum bog

A small sphagnum bog (less than 1 acre) lies near the north end of Division Street in the town of Suquamish. It has the usual flora of bog shrubs. It is shallow (2 to 3 feet) and rests on clay.

Lost Lake peat area

The Lost Lake peat area (30 acres) is in sec. 15, T. 23 N., R. 1 W., 8 miles southwest of Bremerton. It is reached by State Highway 14 and an unimproved road leading west from the highway to the vicinity of the peat. This unimproved road joins the highway at a point 1.8 miles southwest of the Bremerton airport.

Lost Lake is in the southern part of the peat area. The peat lies in a depression in glacial drift. The forest on the adjoining land has been logged. On the soil map of Kitsap County (Wildermuth et al., 1939) the area is mapped as Spalding peat.

This is a very wet bog with an unusual association of living *Sphagnum* moss, swamp shrubs, and swamp and aquatic herbs. The combination of hardhack, rushes, and water lilies with a thick cover of living *Sphagnum* on the surface of the peat illustrates this plant community. Water, 1 to 3 feet deep, stood on the surface in some places on July 1, 1950. In the vicinity of the lake the water was more than 3 feet deep.

Though there is much living *Sphagnum* on this peat area, it has formed very little peat (fig. 87). What sphagnum peat there is, is near the margin. Farther out the *Sphagnum* forms a loose growth in the water. Most of the peat in this deposit is fibrous and is brown to dark brown. The upper part of this peat is soft, but toward the bottom it is compact, and at the bottom it is too compact to be penetrated with the peat borer. At the 3-foot level it is strongly acidic (pH 3.8).

No evidence of any attempts at utilization was seen. The lack of drainage, the watery character of the surface peat, and the extreme compactness of the peat at the bottom render the area unfavorable for utilization.

Mace Lake peat area

The Mace Lake peat area (29 acres) is in sec. 5, T. 22 N., R. 2 E. It is 13 miles southeast of Port Orchard, from

T 23 N, R 1 W

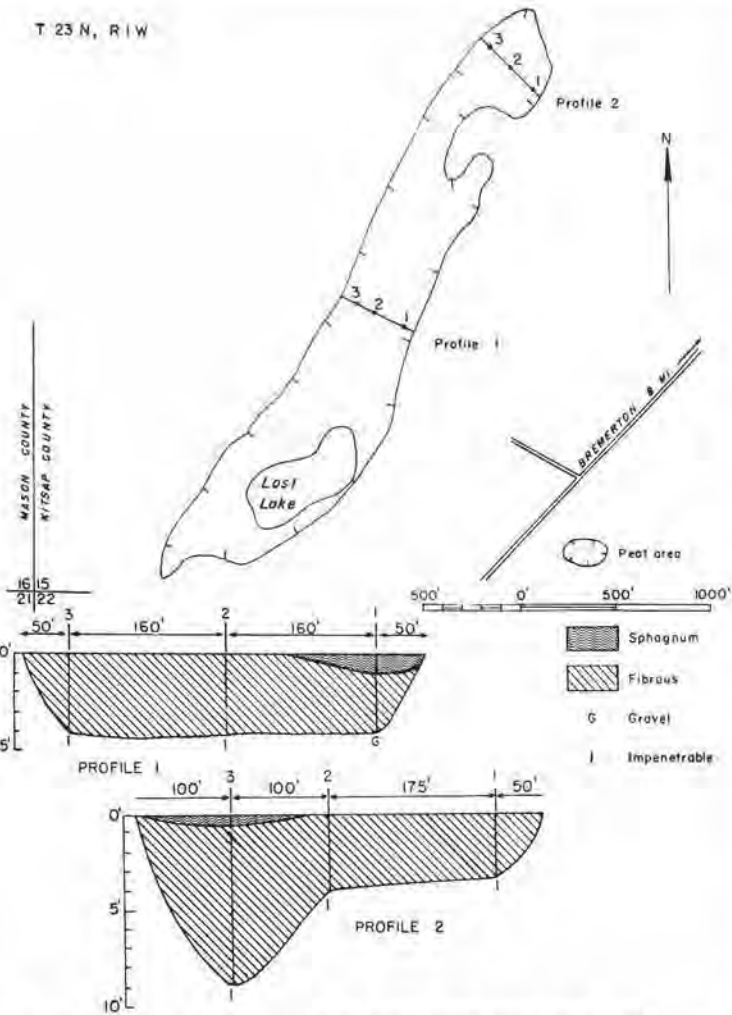

which it is reached by State Highway 14 and county roads. It is a little over 2 miles east of Burley. The peat is mapped as Greenwood peat on the soil map of Kitsap County (Wildermuth et al., 1939).

The central part is a sedge meadow with a slender species of *Sphagnum* growing on the surface among the sedge stems. There is hardhack brush in some places, and a wide zone of hardhack around the margin. Water lilies and erect aquatic herbs grow in some places, especially in the vicinity of the lake.

The peat in this deposit is fibrous and sedimentary, mostly a mixture of the two (fig. 88). The *Sphagnum* which grows on the surface has not formed any peat. The fibrous peat, alone and mixed with sedimentary peat, is brown to dark brown, and some of it is very watery. It varies from raw to decomposed. There is some hypnum peat mixed with it in a few places. The layer of brown pumicite is 1/2 to 1 inch thick.

Gurley Creek peat area

The Gurley Creek peat area (23 acres) is in sec. 8, T. 23 N., R. 2 E., about 5 miles southeast of Port Orchard. It lies close to the north end of Long Lake but does not border it (map, fig. 89). Gurley Creek, which is about 3 miles long, flows from the lake to the salt water of Yukon Harbor, crossing the northern part of the peat area. The peat lies in a gently rolling region of glacial drift, and is mapped as Rifle peat on the soil map of Kitsap County (Wildermuth et al., 1939).

The north end of the peat, near Gurley Creek, was investigated. This includes some swamp forest of small trees and also some open areas. In one of the open areas there is an old commercial cranberry bog (a quarter of an acre) and a drainage ditch near it.

At the margin of the commercial bog the peat is more than 45 feet deep (fig. 89). Bottom was not reached be-

FIGURE 87.—Map and profiles of Lost Lake peat area (30 acres). Map adapted from U. S. Army Map Service photomosaic.

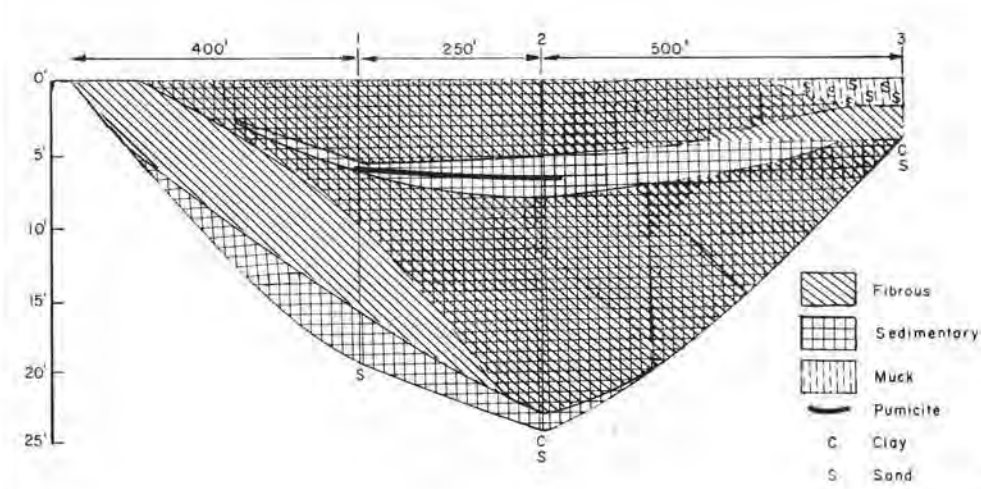

T. 22 N., R. 2 E.

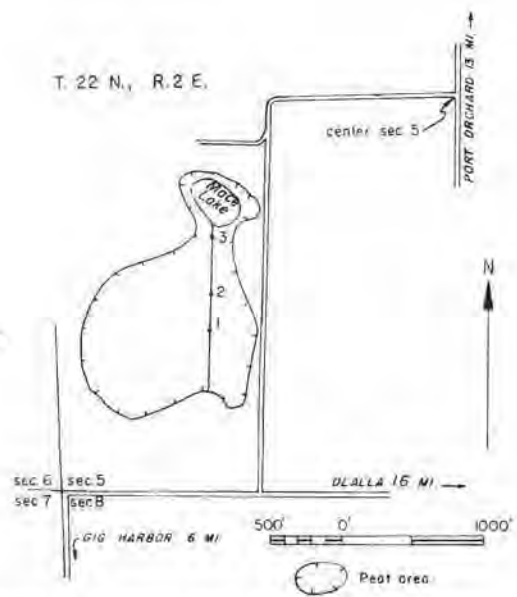

FIGURE 88.—Map and profile of Mace Lake peat area (29 acres). Map adapted from U. S. Army Map Service photomosaic.

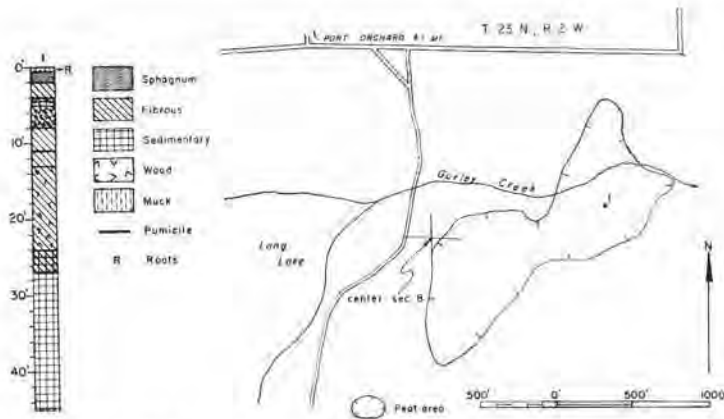

FIGURE 89.—Map and graphic log of a hole in Gurley Creek peat area (23 acres). Map adapted from U. S. Department of Agriculture soil map of Kitsap County.

cause, although the peat is soft and easily penetrated at that depth, a shortage of equipment available at the time prevented deeper boring.

The sphagnum in the layer near the surface is relatively free from roots and other extraneous material. Wood peat is abundant from the 4-foot to the 8-foot level and is scattered through the fibrous peat at deeper levels. The fibrous peat is brown to dark brown, and most of it is decomposed. Some of it is watery, and all of it is soft except at the 16- to 17-foot level, where there is a compact layer. The sedimentary peat is brown. The ½-inch layer of pumicite at the 11-foot level is white, and the 2-inch layer of pumicite exposed in the bank of a drainage ditch about 150 feet north of the boring is yellowish brown. The peat varies from strongly acidic (pH 3.7) in sphagnum at the 1-foot level to weakly acidic (pH 5.6) in sedimentary peat at the 45-foot level.

The commercial cranberry bog produced well for several years, but it is now overrun with weeds, alsike clover, Labrador tea, and young alder trees, and is practically abandoned. The vines used in establishing the bog were obtained from the Grayland commercial cranberry region in Pacific County. The berries from the Gurley Creek bog sold well locally during World War II.

This seems to be a favorable area for the commercial production of cranberries. The favorable conditions are good peat, a mild climate, and an abundance of water. The peat lies very near sea level, and its nearness to Puget Sound gives it a somewhat oceanic climate.

Weather data at Bremerton, only a few miles distant, indicate moderate temperatures and abundant, but not excessive rainfall. The mean annual temperature is 51.1° F. The highest temperature recorded during the 40 years for which records are available is 98° F. (June) and the lowest is 14° F. (January). The average length of the growing season is 211 days; the latest killing frost recorded is April 28, and the earliest is September 25. The average annual snowfall is 16.4 inches. No snowfall has ever been recorded in June, July, August, or September, and only a trace in May and October. The average annual precipitation is 37.45 inches. In 1936 there were only 130 clear days; the rest were cloudy or partly cloudy. During

a large part of the year the sun is hidden from view by rain, fog, and clouds.

There is plenty of water in the peat, and the ditches seem to provide sufficient surface drainage. Water is being pumped from the creek for use on the ranch in which the old commercial cranberry bog is located. Apparently there is sufficient water for flooding cranberry areas to prevent injury by low temperatures, if this should be necessary.

Square Lake peat area

The Square Lake peat area (21 acres) is in sec. 16, T. 23 N., R. 1 E., about 5 miles southwest of Port Orchard by county roads and an unimproved road. The peat surrounds the lake (map, fig. 90). Square Creek flows from the north end of the lake, and its water eventually reaches Sinclair Inlet at Port Orchard. On the soil map of Kitsap County (Wildermuth et al., 1939) the peat area is mapped as Spalding peat, and the area surrounding it is mapped as Everett gravelly sandy loam.

The part of the peat area south of the lake was investigated. This part is a very wet sphagnum bog. In June 1950, in the vicinity of the profile there was 6 inches of standing water at the south end, and this increased to 3 feet near the lake.

There are two distinct stages of development in the bog. The more extensive area bordering the lake is in a very early stage of development, and the plant community there comprises aquatic species (water lilies and buckbean) with some sedges. A slender species of *Sphagnum* grows in the water among these plants. Near the southeast border of the bog there is a later stage of development in which a robust species of *Sphagnum* forms a dense thick layer among the stems of bog shrubs (Labrador tea and bog laurel). Native cranberry and sundew are common. This later stage is advancing on the earlier stage, and the level of the surface of the advancing margin is 1 to 2 feet higher than that of the earlier stage. There are also some patches of this later stage farther out toward the lake. There are some small lodgepole pine trees

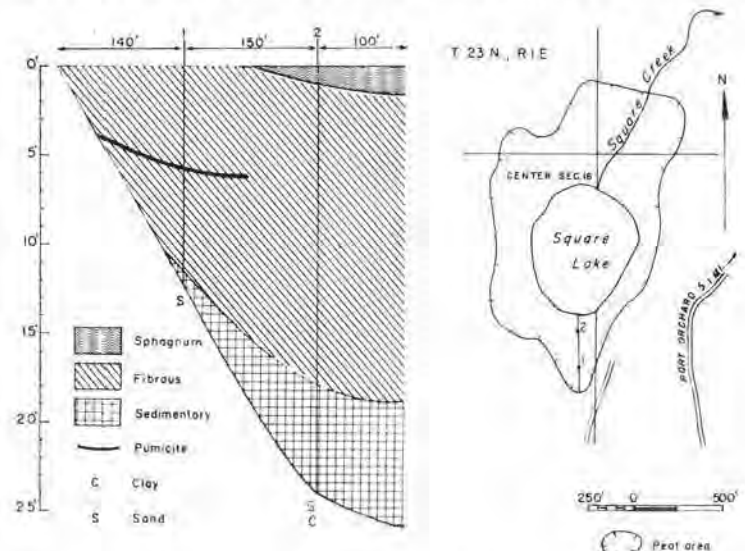

FIGURE 90.—Map and profile of Square Lake peat area (21 acres). Map adapted from U. S. Army Map Service photomosaic.

and a few small cedar trees in the main area of this later stage. It seems probable that if this peat area remains undisturbed, the robust species of *Sphagnum* with its accompanying shrubs will overrun the earlier stage area, and in the course of years there will be a considerable accumulation of good moss.

Most of the peat in this profile is fibrous (fig. 90). It is brown, and it varies from raw near the surface to disintegrated and decomposed at deeper levels. It is all soft, and some of it is watery. The sedimentary peat varies from olive brown to olive green. It is soft at the top of the layer and compact at the bottom. This peat deposit rests on

sand and clay. Though living *Sphagnum* is abundant, it has formed very little peat. The layer of brown pumicite is 2 inches thick.

Kitsap Lake peat area

The Kitsap Lake peat area (19 acres) is in sec. 17, T. 24 N., R. 1 E., about 3 miles west of Bremerton. It borders the south side of the lake (map, fig. 91). A small stream flows sluggishly across the peat to the south end of the lake, and Chico Creek flows from the north end of the lake to the salt water of Dye's Inlet. The lake and the peat lie in a depression in glacial drift. The peat is shown

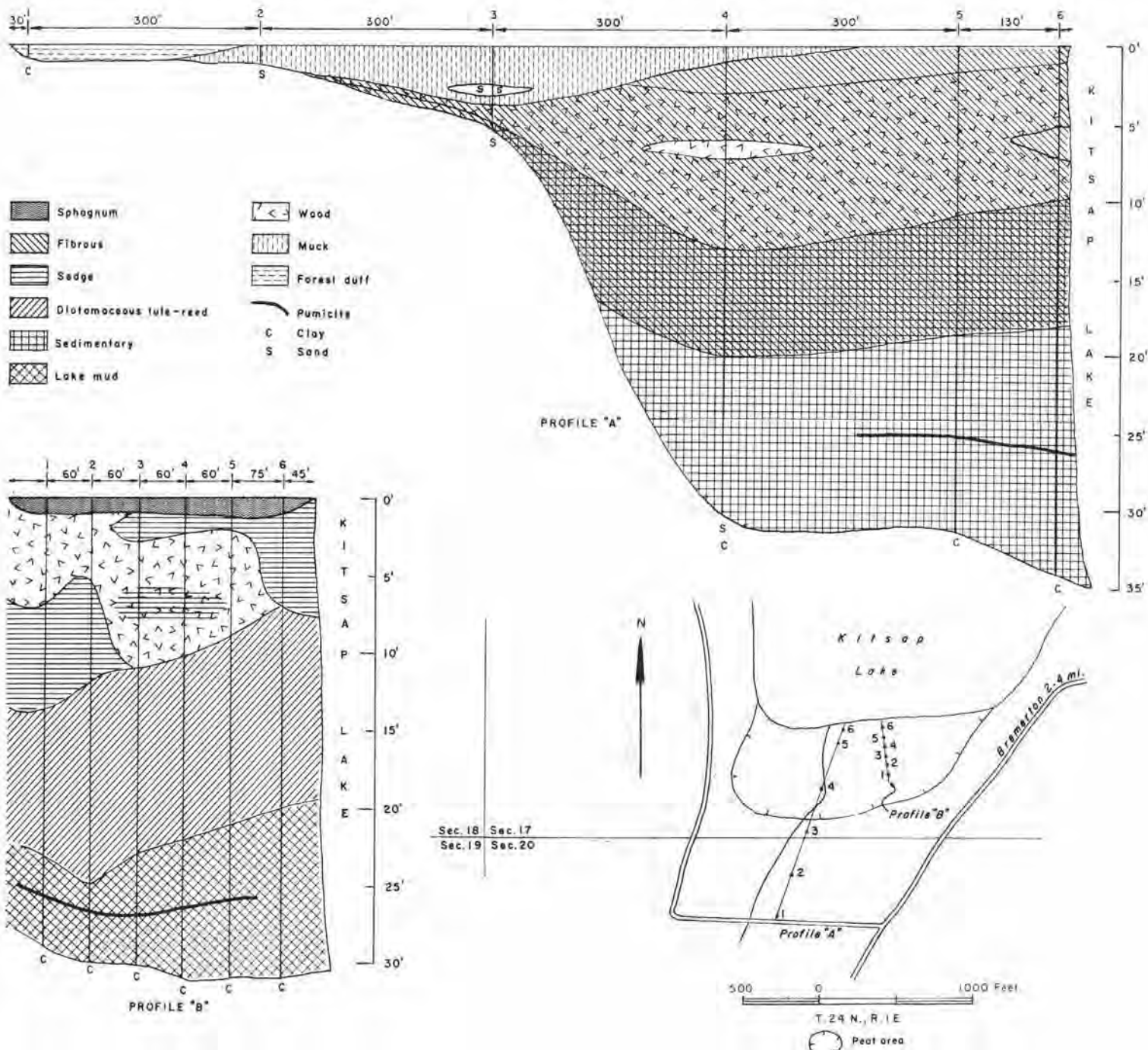

FIGURE 91.—Map and profiles of Kitsap Lake peat area (19 acres). Map adapted from U. S. Army Map Service photomosaic.

on the soil map of Kitsap County (Wildermuth et al., 1939) as alluvial soils, undifferentiated.

This peat is covered with swamp forest varying from coniferous forest at the south, in which there has been some logging, to small alders, willows, and swamp dogwood at the lake shore. The shrubby undergrowth in the forest includes salmon berry, devilsclub, and hardhack; and the herbaceous undergrowth includes ferns and skunk cabbage.

The profile (profile A, fig. 91) shows a transition from forest duff to muck to fibrous peat. The muck is black. The fibrous peat is dark brown and soft, and some of it is decomposed. In general, the mixture of fibrous peat and woody peat has the same physical properties as the sedge peat. The sedimentary peat varies from olive brown to olive green and is compact at the bottom. The layer of white pumicite is 1/2 to 1 inch thick. The peat rests on gray and blue clay and gray sand.

A profile (profile B, fig. 91) by Rigg and Richardson (1938) is based on field work done in 1937. It extends 360 feet south from the south shore of the lake and shows a little over 1 foot of sphagnum. The sphagnum was not found in the borings made for the 1950 profile, which is farther west than the earlier one. The thicket of trees and shrubs near the lake shore has increased in area and density between the time of the two investigations.

Lofall peat area

The Lofall peat area (19 acres) is in sec. 25, T. 27 N., R. 1 E., about 3 miles by road southwest of Lofall and about 6 airline miles west of Kingston. State Highway 21 (Bremerton to Port Gamble to Kingston) passes through Lofall, which is on the shore of Hood Canal. There is a county road to a ranch not far from the peat, and an old logging road leads on to the immediate vicinity of the peat. From the end of this road the peat is reached by walking down a steep slope over logged-off land. The peat lies in an undrained depression in glacial drift. It is mapped as Greenwood peat on the soil map of Kitsap

County (Wildermuth et al., 1939), and an extensive area surrounding the peat is mapped as Alderwood loam.

A considerable part of the peat area in the vicinity of hole 2 of the profile is sphagnum bog with a growth of low bog shrubs (Labrador tea and bog laurel) on it. In the vicinity of hole 1 there are cattails, and the surface of the peat is covered with old, partly burned logs and the general debris of logging. In the vicinity of holes 3 and 4 there are other plant communities—sedge swamps, water lilies and other aquatic plants, some brushy thickets in which old snags of conifers still stand, and various transition zones where these border one another.

Most of this peat deposit (fig. 92) consists of fibrous peat and its mixture with other materials. Though living *Sphagnum* is common on the surface, it has formed very little peat. The 20 inches of sphagnum at hole 2 is of good quality except that it is dark colored. The small amount of sedimentary peat at the bottom of hole 3 is olive green and compact. The fibrous peat is soft and varies from light brown to dark brown. A small amount of it is raw, but most is decomposed. At the 12-foot level in hole 3 it is rather strongly acidic (pH 4.5).

No evidence of any attempt at utilization was seen. The lack of drainage from the depression in which the peat lies is unfavorable for utilization for crops though not necessarily for the removal of the peat. The lack of an access road at present is also unfavorable.

Sunnyslope peat areas

Eight relatively small areas of Greenwood peat and two areas of Spalding peat, all lying in an area of Alderwood loam and all within 8 miles southwest of Port Orchard, are mapped on the soil map of Kitsap County (Wildermuth et al., 1939).

The larger area of Spalding peat (13 acres) is in sec. 7, T. 23 N., R. 1 E., and sec. 12, T. 23 N., R. 1 W. (map, fig. 93), about a quarter of a mile southwest of the village of Sunnyslope. The plants growing on the northeastern part

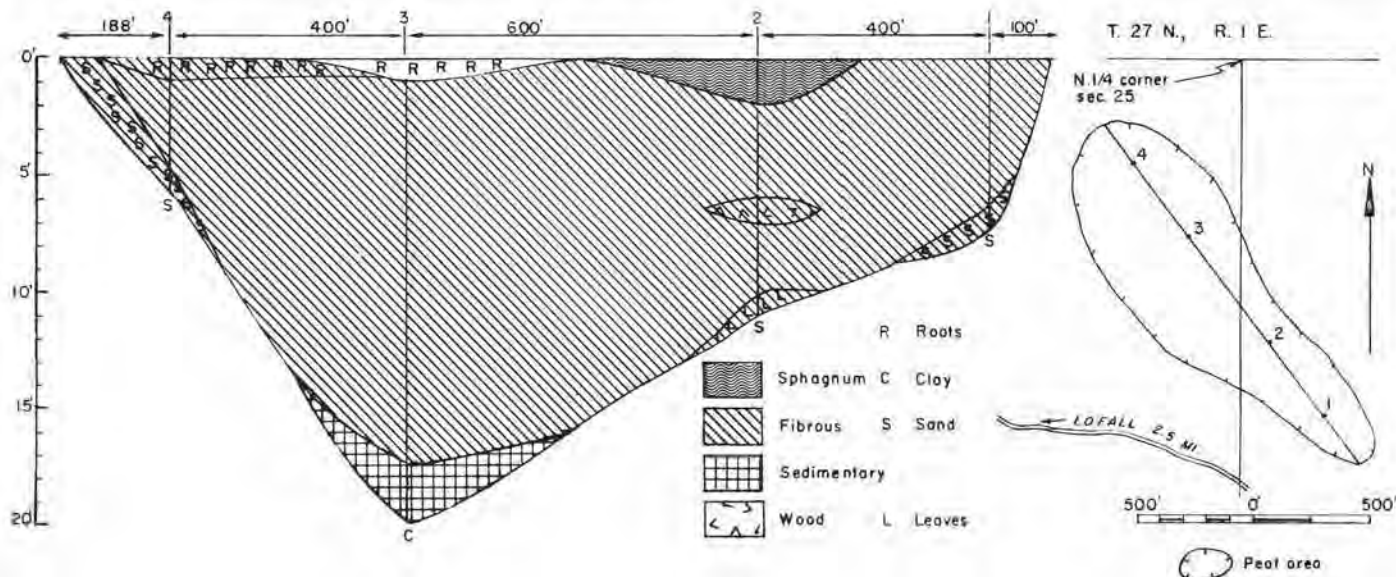

FIGURE 92.—Map and profile of Lofall peat area (19 acres). Map adapted from U. S. Army Map Service photomosaic.

of this area are hardhack, sedges, rushes, buttercups, gentians, and *Sphagnum*. There is a drainage ditch in the vicinity of hole 2.

The peat in this deposit (fig. 93) is nearly all fibrous. It varies from light brown to black and from disintegrated

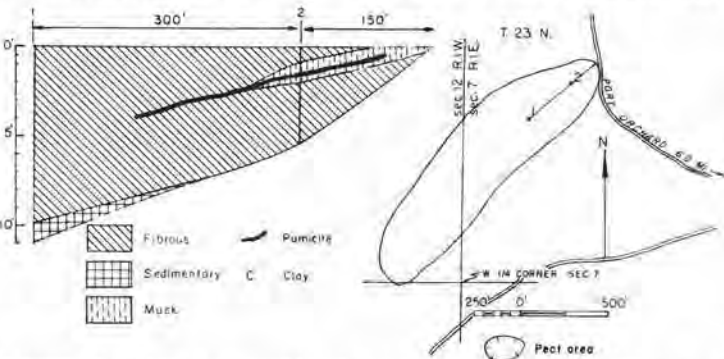

FIGURE 93.—Map and profile of Sunnyslope peat area (13 acres). Map adapted from U. S. Department of Agriculture soil map of Kitsap County and U. S. Army Map Service photomosaic.

to completely decomposed. The muck is black, and the sedimentary peat is olive brown. Associated pumicite is brown and forms a layer 1 inch thick. The peat rests on blue clay.

The other of these Spalding peat areas (3 acres, estimated) is parallel to the one described above and a few hundred feet east of it. It has been burned, and there are some down logs on it. Its vegetation includes hardhack, sedges, and some *Sphagnum*. The deposit has a depth of only 2½ feet of fibrous peat, and it rests on clay. A layer of pumicite at the 1-foot level is brown.

The eight small areas of Greenwood peat shown on the soil map of Kitsap County have not been investigated.

Glenwood peat area

The Glenwood peat area (13 acres) is in sec. 6, T. 22 N., R. 1 E., about 2½ miles northwest of Glenwood and about 10 miles by road southwest of Port Orchard. An improved road passes close to the north end of the peat. On the soil map of Kitsap County (Wildermuth et al., 1939) it is mapped as Greenwood peat, and the extensive area around it is mapped as Everett gravelly sandy loam.

In June 1950 there was 6 to 12 inches of standing water on this peat. The trees on it are lodgepole pine, crab apple, aspen, and cascara. Some of the pines are as much as 20 feet tall. The shrubs are Labrador tea, hardhack, and wild rose.

One hole near the center of the area shows 8 feet of fibrous peat overlying 1 foot of sedimentary peat, which rests on gravel. The fibrous peat is dark brown to black and disintegrated to decomposed. It is soft, except near the surface, where there is a hard layer. The sedimentary peat is olive brown and contains some fibers and some clay. A 1-inch layer of pumicite at the 1-foot level is brown.

There is a drainage ditch in the middle of the peat area, but the ditch was not traced to its outlet.

Seabeck peat area

The Seabeck peat area (5 acres, estimated) is in sec. 20, T. 25 N., R. 1 W. It is on the peninsula which separates Seabeck Bay from the main channel of Hood Canal and is about 1 mile from Seabeck by a road which extends around the head of the bay. It is mapped as Greenwood peat on the soil map of Kitsap County (Wildermuth et al., 1939). It is in a ravine, through which there may be some drainage to the southeast. The surrounding area is mapped as Everett gravelly sandy loam.

Most of this area is a sphagnum bog. A sketch map and profile were published by Rigg and Richardson (1938). The profile is redrawn from their publication, and the map (fig. 94) is redrawn from their publication and the soil map of Kitsap County (Wildermuth et al., 1939). The region was logged long ago, and the channels across the bog were evidently made by dragging logs across it.

No data on this bog since 1937 are available. At that time it had the usual flora of bog shrubs, and *Sphagnum* was growing vigorously among them. There were some small coniferous and deciduous trees in the sphagnum, and aspen, crab apple, and hardhack grew in the zone of peat which surrounded the sphagnum area.

Miller Lake peat area

The Miller Lake peat area (9 acres) is in secs. 21 and 28, T. 27 N., R. 2 E., about 3 miles west of Kingston. A

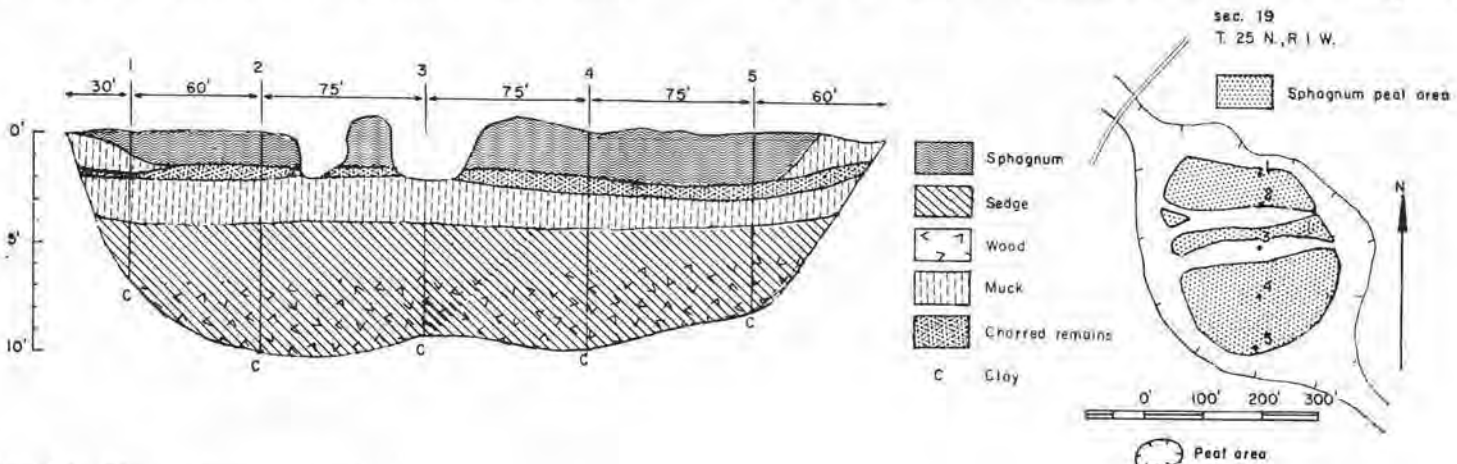

FIGURE 94.—Map and profile of Seabeck peat area (5 acres, estimated). Map adapted from Rigg and Richardson (1938) and U. S. Department of Agriculture soil map of Kitsap County.

paved highway (State 21) crosses the peat (map, fig. 95). The area is mapped as Spalding peat on the soil map of Kitsap County (Wildermuth et al., 1939), and the area so mapped is more extensive than the area mapped in figure 95, which was made from a U. S. Corps of Engineers photomosaic.

Most of the area mapped in figure 95 is covered with a dense growth of willows, but near the center is an open

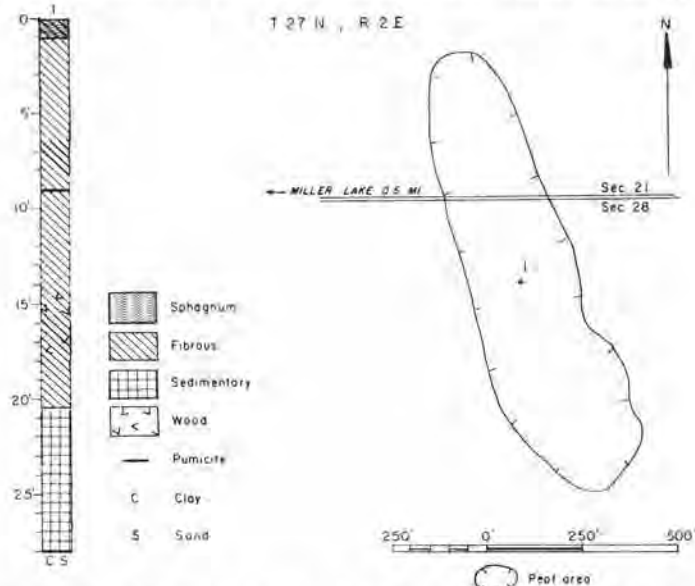

FIGURE 95.—Map and graphic log of a hole in Miller Lake peat area, Kitsap County (9 acres). Map adapted from U. S. Army Map Service photomosaic.

sphagnum bog of about 1 acre in which bracken ferns and skunk cabbage grow with Labrador tea and bog laurel. There are some small cedar trees and some crab apple trees. Living *Sphagnum* forms an almost continuous cover among the stems of the erect plants and also forms some hummocks.

The fibrous peat is brown and varies from raw to disintegrated to decomposed. There is some charred material at the 5-foot level and some wood peat at a depth of 14 to 18 feet. The sedimentary peat is dark green and rests on clay and sand. The ½-inch layer of pumicite is brown.

Roberts Lane peat areas

The two Roberts Lane peat areas (total 12 acres) are in sec. 28, T. 23 N., R. 1 E., about 7 miles by road southwest of Port Orchard. The relation of roads to these two areas is shown on the maps (figs. 96 and 97).

On the soil map of Kitsap County (Wildermuth et al., 1939) the larger of the two areas is mapped as Greenwood peat, and the area around it is mapped as Alderwood loam.

The flora of this peat is composed of lodgepole pine, hardhack, reeds, and some water lilies. Reed canary grass flourishes. The surface is very wet, and there is some shallow standing water.

This peat was drained in about 1935 by a ditch and a line of tile. Oats and vegetables were successfully produced there then. Later, the tile drain was interfered with, and the peat was flooded. The area has not been

restored to crop production, and wild ducks nest there now.

Most of the peat in the larger area (fig. 96) is fibrous, and is brown and disintegrated. The organic soil is black.

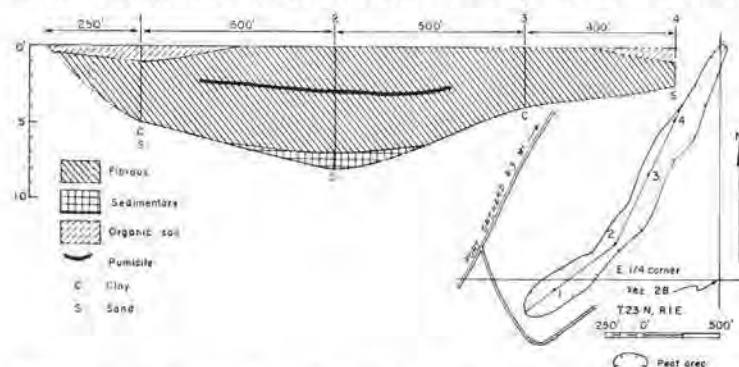

FIGURE 96.—Map and profile of Roberts Lane peat area No. 1 (8 acres). Map adapted from U. S. Department of Agriculture soil map of Kitsap County and U. S. Army Map Service photomosaic.

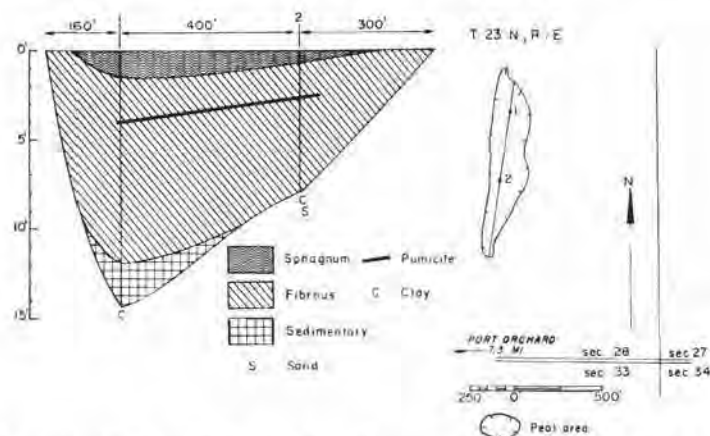

FIGURE 97.—Map and profile of Roberts Lane peat area No. 2 (4 acres). Map adapted from U. S. Army Map Service photomosaic.

The sedimentary peat is olive brown and rests on clay and sand. The 1-inch layer of pumicite is brown.

The smaller area (map, fig. 97) is very wet. The bog shrubs (Labrador tea and bog laurel) grow with aquatic herbs such as water lily and buckbean. *Sphagnum* is growing vigorously over most of the bog and forms a cover 1 to 2 feet thick among the stems of the bog shrubs.

Most of the peat is fibrous (fig. 97). The general characteristics of the fibrous peat and the sedimentary peat are similar to those of the materials in the larger area. The 2-inch layer of pumicite is brown.

The sphagnum is of good quality and could supply a local use, but there is insufficient quantity to justify commercial development.

Mathews Lake peat area

The Mathews Lake peat area (7 acres) is in sec. 28, T. 23 N., R. 1 E., about 7 miles southwest of Port Orchard and about ½ mile south of Mathews Lake. It is mapped as Greenwood peat on the soil map of Kitsap County (Wildermuth et al., 1939).

There are stumps of coniferous trees up to 6 inches in diameter. The living vegetation is characteristic of a swamp. One hole near the center of the area shows 3 feet of mixed fibrous and woody peat, some of which is charred. Under this is 1½ feet of muck with a 2-inch layer of brown pumicite at the 4-foot depth. Under the muck is 1½ feet of fibrous peat, 1 foot of fibrous and wood peat, and 1½ feet of white to brown diatomite resting on gray fine sand.

Teel Brothers peat area

The Teel Brothers peat area (7 acres) is in sec. 7, T. 23 N., R. 1 E., about 5 miles southwest of Port Orchard. A county road extends close to the peat (map, fig. 98).

The vegetation where undisturbed is Labrador tea, hardhack, rushes, grasses, and *Sphagnum*.

The 1 foot of sphagnum peat (fig. 98) is raw and free from extraneous material except that it is somewhat

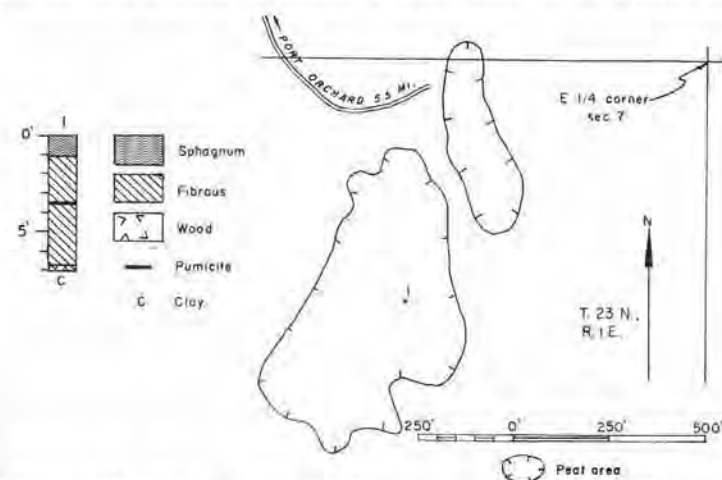

FIGURE 98.—Map and graphic log of a hole in Teel Brothers peat area (7 acres). Map adapted from U. S. Army Map Service photomosaic.

mixed with fibrous peat at the bottom of the layer. The fibrous peat is brown. At some levels it contains a small amount of charred material. It is rather strongly acidic (pH 4.3). Brown pumicite forms a layer 1 inch thick.

In 1950 peat was being excavated and marketed in bulk by Teel Brothers, of Bremerton. The water which has accumulated in the excavation is strongly acidic (pH 4.0).

Nels Johnson Lake peat area

The Nels Johnson Lake peat area (2 acres) is in sec. 17, T. 23 N., R. 1 E., about 6 miles southwest of Port Orchard. It lies very close to Nels Johnson Lake but does not border it. A county road extends near it (map, fig. 99). It is mapped as Greenwood peat on the soil map of Kitsap County (Wildermuth et al., 1939), and the land surrounding it is mapped as Everett gravelly sandy loam.

This area is very wet, and water a few inches to over 1 foot deep stands on most of it. It is mainly covered with hardhack brush, but in some places there are water lilies and sedges. *Sphagnum* is growing in the water or on the peat over most of the area. Some of the area has been burned, but the hardhack is regenerating from the old stems. There are some small, dead, fire-blackened trees.

The sphagnum shown on the profile (fig. 99) consists mostly of loose masses of sphagnum in the water. The fibrous peat is brown and decomposed, and the muck is

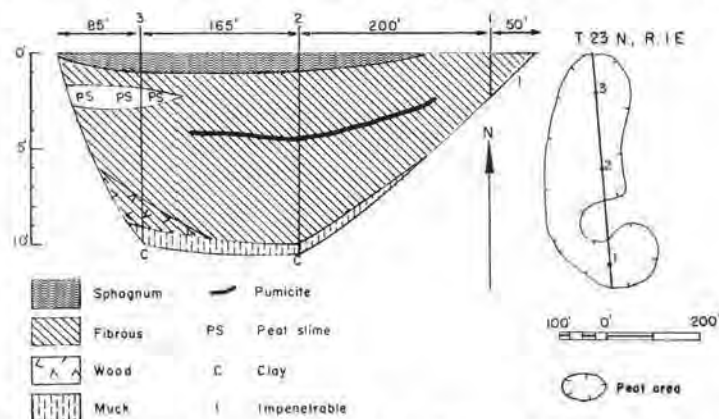

FIGURE 99.—Map and profile of Nels Johnson Lake peat area (2 acres). Map adapted from U. S. Department of Agriculture soil map of Kitsap County and U. S. Army Map Service photomosaic.

brown to black and rests on gray clay. The 2-inch layer of pumicite is brown.

KITTITAS COUNTY DEPOSITS

Kittitas County has very little peat. The Soil Survey of Kittitas County (Smith, Dwyer, and Schafer, 1945, p. 52) gives the total area of surveyed peat as 256 acres, varying in thickness from less than 12 inches to 3 feet or more, resting on clay or clay mixed with sand or silt. The peat occurs in small swampy depressions and near the foot of west slopes from a place near the mouth of the Cle Elum River westward. Several of these peat areas are shown on the soil map (detailed reconnaissance sheet 2) in the valley of the Yakima River. Peat also occurs in many small swampy depressions and seepy areas on slopes in the mountains and in local stream valleys outside the area of detailed survey.

Kachess Lake area

The Kachess Lake area is estimated to contain 25 acres of peat and muck in a swampy area of about 180 acres. It is in sec. 13, T. 21 N., R. 12 E., south of the road which extends to Kachess Lake from the point where U. S. Highway 10 crosses Swamp Creek. Part of Swamp Creek originates in the area. This is not within the portion of the county shown on the soil map of Kittitas County (Smith, Dwyer, and Schafer, 1945).

A boring shows this to be a muck area, containing very little peat. It shows a 1-foot layer of living sedge roots at the surface, underlain by 3 feet of brown muck, 1 foot of brown fibrous peat, 2½ inches of pumicite, and 9½ inches of black muck which rests on bluish-gray clay.

A boring, made by Hansen (1947) for the purpose of collecting fossil pollen, shows a sedimentary column 4.2 meters (about 13 feet 9 inches) deep with a layer of pumicite at a depth of 3.2 meters (about 10 feet 6 inches). It seems probable that this boring was in the Kachess Lake area.

KLICKITAT COUNTY DEPOSITS

Conboy Lake peat area

An estimated 50 acres of peat is known to occur in Klickitat County in the Conboy Lake area a few miles south of Glenwood. Conboy Lake is a lake in name only, as most of its area is devoted to farming. An originally larger swampy area has been ditched so that only a few tens of acres remain poorly drained. Ditches lead to Outlet Creek, a tributary to the Klickitat River. The area known as Conboy Lake lies in a much larger flat area, several miles wide, which extends about 10 miles southwest from Glenwood. The flat appears to be underlain by Quaternary lavas, but the surface is covered by alluvium.

Local farmers have reported peat or muck soils in the Conboy Lake area in portions of secs. 15, 16, 21, 22, 23, 26, 27, 28, 33, and 34, T. 6 N., R. 12 E., but a hasty examination indicates that most of that area is covered by mineral soil and that such peat as may be found would be exceedingly shallow. However, much of the eastern part of sec. 33 was covered by shallow water in the middle of June 1953, when the examination was made, and the deepest peat probably is there. One hole bored near the center of the NE¼ sec. 33, T. 6 N., R. 12 E., where the water was 6 inches deep, was in a pure stand of a low-growing sedge. This hole showed 4 feet of decomposed dark-brown fibrous peat lying on coarse gray sand. At the 2-foot depth was a ½-inch layer of cream-colored pumicite.

Near the center of the W½ sec. 32, near the western edge of the flat area, and about 1½ miles west of the hole mentioned above, is a group of three fairly large springs, in the vicinity of which early settlers reportedly were once able to harvest wild cranberries. This would indicate that *Sphagnum* was growing there at the time, as wild cranberries in Washington, with rare exceptions, grow only in sphagnum bogs. At the present time, however, no sign of living *Sphagnum* nor any accumulation of

moss peat is to be found. A hole near one of the springs in an area covered by short sedges and weeds showed, from top to bottom: 1½ feet of fine disintegrated compact, brown to black fibrous peat containing some wood; 6 inches of white coarse pumicite; 6 inches of black muck; 4 inches of tan diatomite; 2 inches of brown fine pumicite; and 1 foot of black diatomaceous muck.

LEWIS COUNTY DEPOSITS

Davis Lake peat area

The Davis Lake peat area (542 acres) is in secs. 1, 2, 11, 12, and 13, T. 12 N., R. 4 E., and secs. 7 and 18, T. 12 N., R. 5 E. It is reached by driving half a mile southeast from Morton on State Highway 5 (map, fig. 100). The peat area entirely surrounds Davis Lake, the surface of which is at an elevation of about 950 feet. The peat and the lake lie in a valley partially dammed by glacial debris. A stream whose water eventually reaches the Cowlitz River flows into the lake from the southeast and out of it at the northwest end. The peat is mapped on an unpublished map of the U. S. Soil Conservation Service as well as on a published soil map of Lewis County (Fowler and Ness, 1954), where it is shown as Rifle peat. The topography of the region is shown on the Eatonville quadrangle.

Holes 1 and 2 of the profile (fig. 100) are in a hayfield of reed canary grass. At hole 3 there are ash trees, small alder trees, hardhack brush, and reed canary grass. Hole 4 is in the transition zone from the swamp vegetation of the lake shore (sedges, scouring rushes, and water lilies) to the swamp forest of alder and ash (up to 18 inches in diameter), under which hardhack and nettles grow. Hole 5 is in the swamp forest.

The kinds of peat found in the profile are fibrous, woody, sedimentary, and peat slime. Muck, silt, and pumicite are also present. The peat at hole 1 rests on blue clay; at holes 2, 3, and 4 it rests on soft gray clay; and at hole 5 it rests on sandy, gravelly clay.

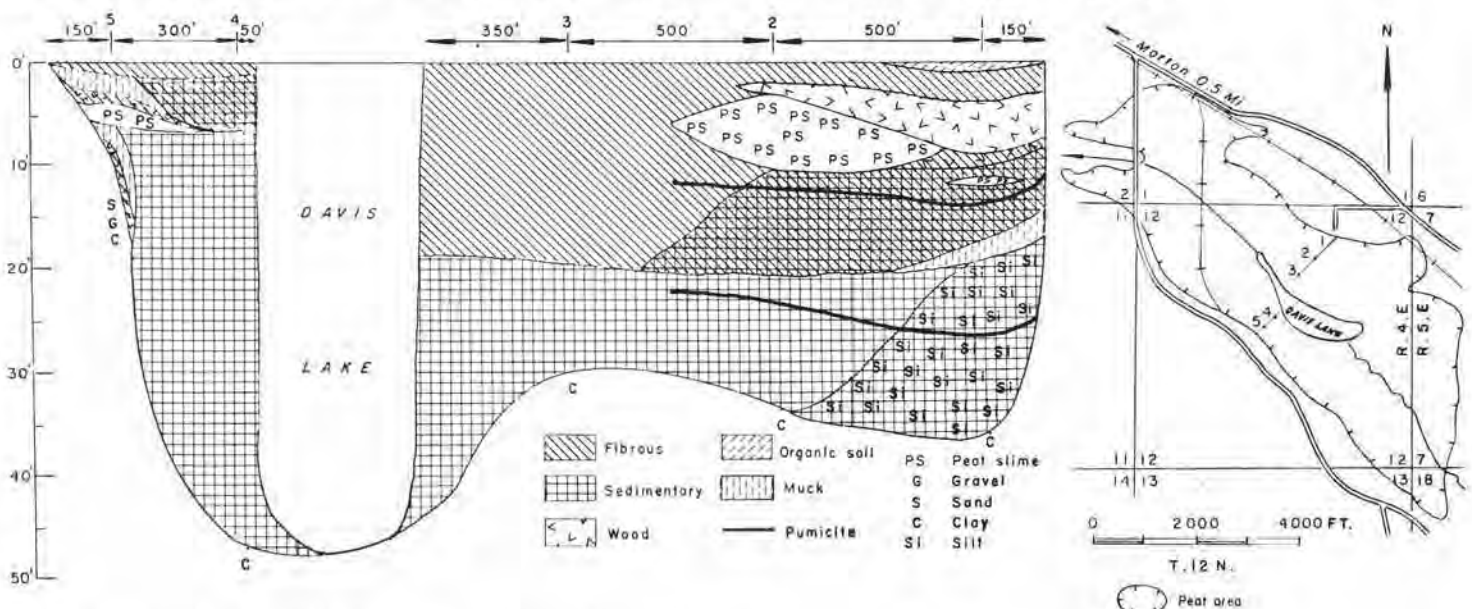

FIGURE 100.—Map and profile of Davis Lake peat area, Lewis County (542 acres). Map adapted from U. S. Department of Agriculture soil map of Lewis County.

The fibrous peat is brown and ranges from disintegrated to decomposed. The woody peat is brown and disintegrated. The sedimentary peat is olive to olive green. The upper layer ($\frac{1}{2}$ inch thick) of pumicite found in holes 1 and 2 is gray; the lower layer ($\frac{1}{2}$ inch thick) is coarse and white at hole 1 and gray at hole 2. The peat slime at hole 2 is brown. Some silt is mixed with the sedimentary peat in the lower part of hole 1.

The peat area was being used in 1951 for pasture and for the production of hay. At Kosmos, which is about 3 miles southeast of this peat, the average length of the growing season for the 22 years preceding 1941 was 147 days, and the average annual precipitation for the 23 years preceding 1941 was 57.82 inches.

Mineral peat area

The peat area (148 acres) half a mile west of Mineral is in secs. 7 and 8, T. 14 N., R. 5 E. (map, fig. 101). State Highway 5 crosses it between Elbe and Morton. The elevation of the area is 1,490 feet. The area is mapped as Rifle peat on the soil map of Lewis County (Fowler and Ness, 1954).

Hole 1 of the profile is at the side of a drainage ditch at the margin of a grass pasture. Hole 2 is in a swamp forest of alder, which has an undergrowth of hardhack, sedges, and skunk cabbage. Holes 3 and 4 are in a swamp forest of spruce, hemlock, and alder, which has an undergrowth of hardhack and skunk cabbage.

The fibrous peat, which comprises most of the deposit (fig. 101), is dark brown and varies from disintegrated to decomposed. The muck is brown to dark brown. Pumicite occurs in two layers in this deposit; in the upper layer it is brown and is 1 to 2 inches thick, and in the lower layer it is 3 inches thick and is coarse and gray. The clay and sand on which the peat rests vary from gray to blue.

Forest peat area

The Forest peat area is in sec. 28, T. 13 N., R. 1 W., about 2 miles southeast of Forest and about $4\frac{1}{2}$ miles east of Napavine.

It is only a small mound of peat, less than 1 acre in area. Formerly there were springs under and around it,

but since an artesian well was bored nearby, the flow from the springs has decreased. The former vegetation is now mostly destroyed, and grass and shrubs cover the peat.

The upper 1 foot of peat is a mixture of dark-brown sphagnum and fibrous peat which is weakly acid (pH 5.0). Below this is 2 feet of dark-brown fibrous peat which ranges from disintegrated to decomposed. Under this is 6 inches of wood peat, then 6 inches of black muck which rests on gray clay.

This small bog evidently formed over springs. Probably, before it was disturbed by man's activities, it was similar in some ways to small bogs occurring in Ohio and Utah and one in Yellowstone Park (Rigg, 1942).

LINCOLN COUNTY DEPOSITS

Creston peat and muck area

The Creston peat and muck area (10 acres) is in sec. 13, T. 26 N., R. 34 E., about 2 miles east of Creston and a few hundred feet south of U. S. Highway 2. This is the only peat deposit reported in Lincoln County.

It lies in an over-deepened part of a channel in the scablands and surrounds a pond estimated to be 800 feet long and 200 feet wide. (See Bretz, 1923, for a discussion of the channeled scablands of the Columbia Plateau.) The plants growing on the peat and muck and in the margin of the pond are mostly sedges, cattails, and tules (bulrushes).

A hole bored east of the pond reveals seven kinds of material, two of which form three layers each. Two layers of pumicite are present. The materials penetrated in the hole, from top to bottom, were: 5 inches of fibrous peat, 1 inch of diatomite, 1 foot 6 inches of muck, 2 feet of fibrous peat, 1 foot of muck, 8 inches of tan pumicite, 4 inches of muck, 1 foot of diatomite, 1 foot of wood peat, 1 foot of fibrous peat, 3 feet of sedimentary peat (with a $\frac{1}{2}$ -inch layer of white pumicite at the 10-foot depth), and 1 foot of mixed sedimentary peat and clay resting on solid rock. The fibrous peat is brown and decomposed. The muck is dark brown to black. The woody peat is dark brown, and the sedimentary peat is olive green. The

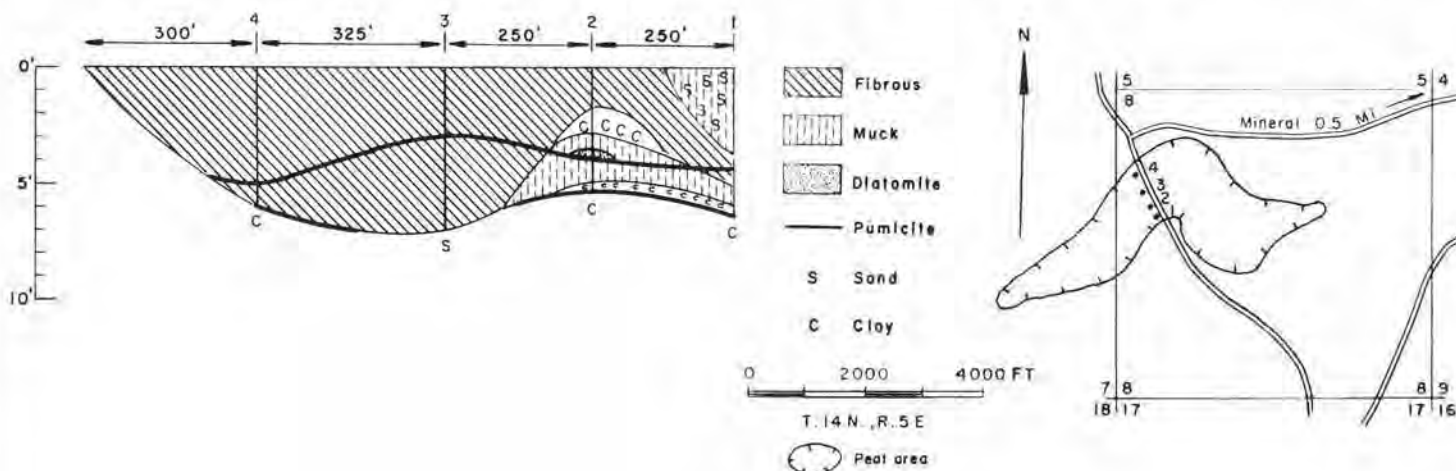

FIGURE 101.—Map and profile of Mineral peat area (148 acres). Map adapted from U. S. Department of Agriculture soil map of Lewis County.

diatomite is gray in color and is almost pure, having only a slight admixture of organic matter. The clay mixed with the sedimentary peat at the bottom is gray.

Hansen (1947) bored this peat area to obtain fossil pollen. He found 2.6 meters (8 feet 6 inches) of sediments with a layer of pumicite 1.1 meters (3 feet 7 inches) below the surface. Irregularities in the depth of this peat would be expected, as it lies in a scabland channel in solid basalt.

The land surrounding the peat is used for pasture, and stock range onto the margin of the peat.

MASON COUNTY DEPOSITS

Deer Creek peat area

The Deer Creek peat area (500 acres) is in secs. 9, 10, 16, 17, 19, 20, 21, 29, and 30, T. 21 N., R. 2 W., about 7 miles northeast of Shelton. State Highway 14A (Shelton to Belfair) passes about 3/4 mile southeast of the peat. Several county roads give access to the peat area (map, fig. 102). The peat lies along both sides of Deer Creek for a distance of about 6 miles, from a point near the head of the creek to a point about 2 miles from its mouth at the head of Oakland Bay. It is mapped as Mukilteo and Rifle peat on the unpublished soil map of Mason County (Ness et al.).

Much of this peat area is a wet sedge meadow with aquatic species growing among the sedges. Alders, willows, and hardhack grow near the margin. Some of the area has been burned.

The peat revealed in the profile (fig. 102) is mostly fibrous and sedimentary, but much woody peat is mixed with the fibrous peat, and there is one layer of pure woody peat. The fibrous peat is brown to dark brown and ranges from disintegrated to decomposed. There is some charred material at the 4- to 5-foot depth in hole 3. The color of the sedimentary peat varies from olive to olive green to dark green and brown. The pumi-

cite found in hole 2 is brown and forms a layer half an inch thick. The peat rests mostly on blue clay, but there is gray sand at the bottom of hole 1 and blue sand with the blue clay at the bottom of hole 4.

Johns Creek peat area

The Johns Creek peat area (500 acres) is in secs. 1 and 2, T. 20 N., R. 4 W.; secs. 25, 26, and 36, T. 21 N., R. 4 W.; secs. 30, 31, and 32, T. 21 N., R. 3 W.; and secs. 5 and 6, T. 20 N., R. 3 W. It is about 4 miles north of Shelton. U. S. Highway 101 passes about 1/2 mile west of it, and several improved and unimproved roads give access to the peat at different places (map, fig. 103). The peat at the profile, which extends northward from the north shore of Johns Lake, is reached from an unimproved road which ends 200 feet north of the profile and about 80 feet above it. Johns Creek heads in a small lake and flows eastward about 8 1/2 miles to Oakland Bay. A very short tributary drains Johns Lake to Johns Creek. Peat borders the north and east shores of Johns Lake, and borders the tributary as well as all but the lower 2 miles of the main creek. The peat area is thus about 6 1/2 miles long but averages only about 500 feet wide. It is shown on the unpublished soil map of Mason County (Ness et al.) as Mukilteo, Greenwood, and Rifle peat.

Only the small area bordering the north shore of Johns Lake was examined. This is a sphagnum bog in which herbaceous and shrubby species occur. There are also some herbaceous species which are more characteristic of swamps than of bogs, and some shrubs (e. g., salal) which are not very commonly found in sphagnum bogs. Pigeon wheat moss, which is characteristic of dry bogs, is abundant in places, and living *Sphagnum* is common. In general, the area is wet at the lake shore, somewhat drier farther back, and merges into a zone of hardhack, sedge, and living *Sphagnum* at the outer margin.

This deposit (fig. 103) contains an unusually large proportion of sedimentary peat, and some of this has unusual

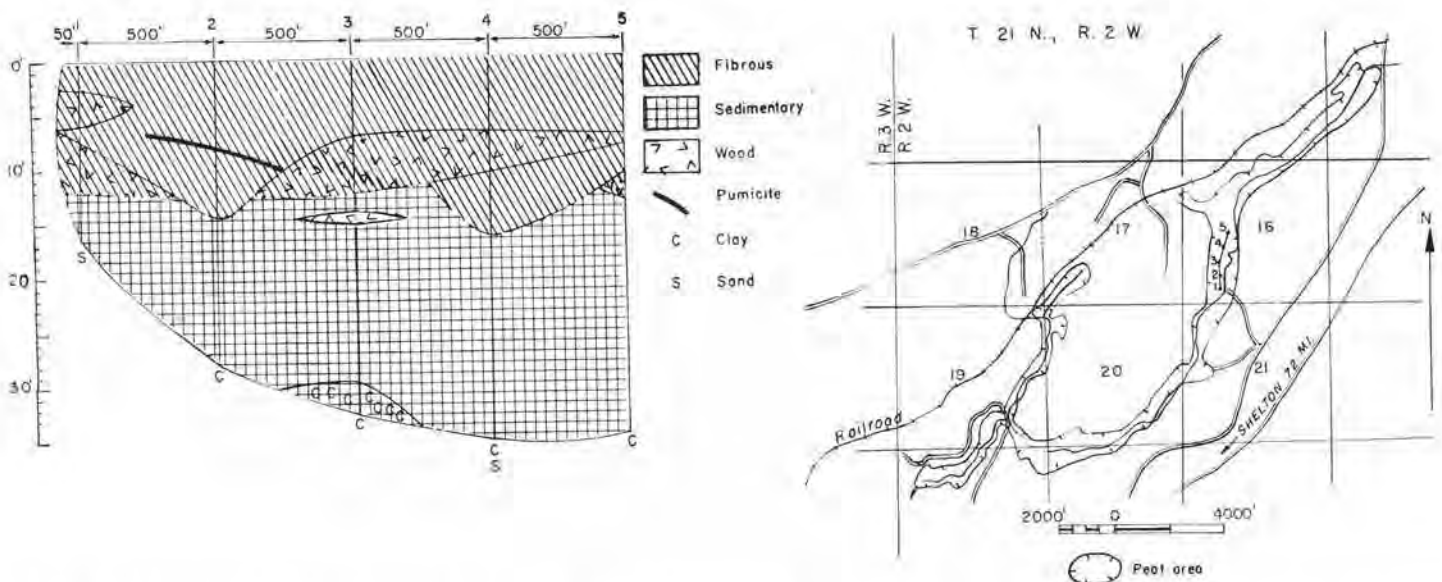

FIGURE 102.—Map and profile of Deer Creek peat area, Mason County (500 acres). Map adapted from U. S. Department of Agriculture unpublished soil map of Mason County.

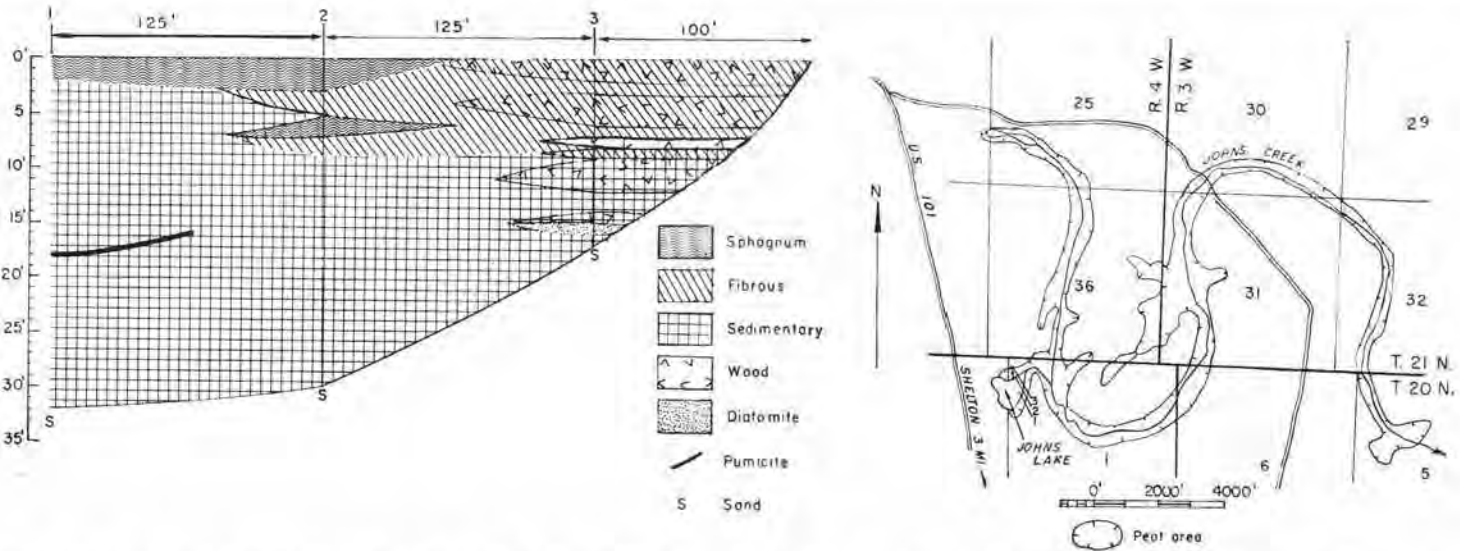

FIGURE 103.—Map and profile of Johns Creek peat area (500 acres). Map adapted from U. S. Department of Agriculture unpublished soil map of Mason County.

properties. All of it found above the 25-foot level in hole 1, and most of it found in hole 2 has the consistency of soft jelly and is light yellow to tan and light brown in color. An analysis of this material (no. 49, table on p. 255) does not furnish conclusive evidence that its special properties are due to its chemical composition. (See chap. II, p. 8 for discussion.) The sedimentary peat found in hole 3 and below the 25-foot depth in hole 1 has the usual properties of sedimentary peat. At the bottom of hole 1 it is compact. At the 16-foot depth in hole 1 it is rather weakly acidic (pH 5.5).

The sphagnum in this deposit is brown, and much of it is disintegrated. The fibrous peat is soft, brown, and mostly disintegrated. The diatomite found in hole 3 is dull gray in color, due probably to the mixture of some organic material with it. The pumicite is white. The peat rests on sand.

The bottom of the lake at the margin of the bog is very soft. It is what is known as a "false bottom." This means that the transition from soupy material to firm material is very gradual with increase in depth.

No evidence of any attempt at utilization was seen.

Shelton Valley peat area

The unpublished soil map of Mason County (Ness et al.) shows 320 acres of Rifle and Mukilteo peat in the Shelton Valley in secs. 25, 26, and 35, T. 20 N., R. 4 W. The valley is encircled by good paved roads which lead to Shelton, about 1 mile to the northeast.

This deposit was examined at only one place, near the east quarter corner of sec. 26, T. 20 N., R. 4 W., about 2 miles southwest of Shelton. At this place there is fibrous peat 3 feet deep mixed with some mud and woody remains. Although this one hole can hardly be expected to give an adequate picture of the depth and nature of the peat over so large an area as 320 acres, it is probable that at least a part of this area is underlain by peat similar to that at the hole. The peat lies in Shelton Valley on both sides of Coffee Creek, which flows through the valley to

Oakland Bay at Shelton. The valley was eroded by the creek prior to the latest glaciation; however, the present channel of the creek has been cut subsequent to the formation of the peat, exposing in the stream banks both peat and the underlying lake-bedded clay.

Part of the Shelton Valley peat area is used for pasture and part for hay and other farm crops, but much of it is waste land on which there is only swamp forest of little economic value. This forested area, if cleared and drained, would probably make good crop land.

Skokomish River peat area

The Skokomish River peat area (308 acres) is in secs. 2, 10, and 11, T. 21 N., R. 4 W. It borders U. S. Highway 101 only a few hundred feet south of the junction with State Highway 14 ten miles north of Shelton. It is on the Skokomish Indian Reservation, about 3 miles from Potlatch and about 4 miles from Union.

The peat lies in the river valley north of the Skokomish River and about 1 mile south of the shore of the Great Bend of Hood Canal. Its elevation is only slightly above sea level. The unpublished soil map of Mason County (Ness et al.) shows 67 acres of Greenwood peat and 241 acres of Mukilteo peat.

The peat area is partially a very wet sphagnum bog with standing water in some places, but there is a large swamp forest at the south and east sides. The sphagnum bog is in the herb stage of development, with an abundant growth of swamp and aquatic herbaceous plants flourishing among the bog herbs. The shrub stage, which will eventually follow if the area remains undisturbed, is now represented by a scattered growth of Labrador tea and an abundant growth of wild cranberry vines. The abundant small willows present on much of the bog are representative of the transition stage from swamp to sphagnum bog.

The trees in the swamp forest are cedar, hemlock, and alder. The undergrowth includes salal, swamp ferns, and skunk cabbage.

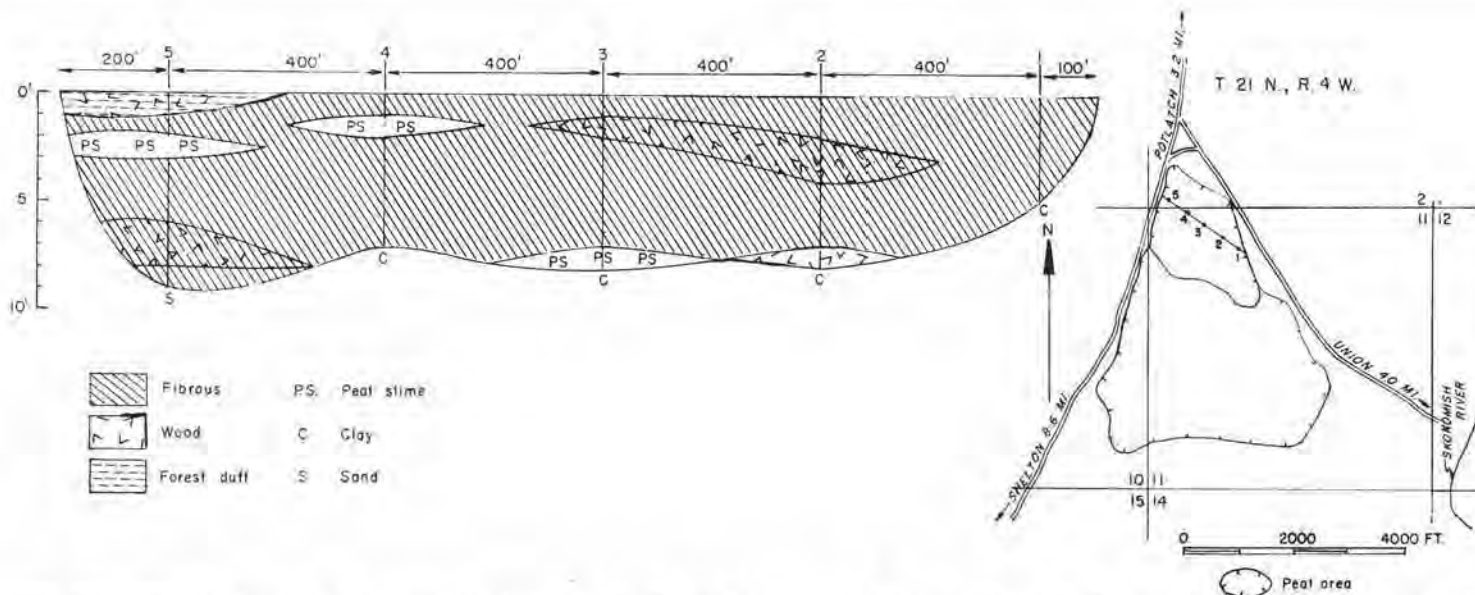

FIGURE 104.—Map and profile of Skokomish River peat area (308 acres). Map adapted from U. S. Department of Agriculture unpublished soil map of Mason County.

The peat deposit is shallow (fig. 104) and consists of fibrous peat, woody peat, and peat slime. Though living *Sphagnum* is abundant on the surface, no sphagnum peat is present in the profile. This situation again emphasizes that this is a very wet bog in an early stage of development. The absence of pumicite in the profile probably indicates that this river-valley bog originated after the time of the volcanic eruption which laid down the ash in the peat deposits of the county which lie in depressions in glacial drift.

The fibrous peat is watery, and its color ranges from brown to dark brown to black. In degree of humification it ranges from raw to disintegrated to decomposed. It rests on gray clay and sand.

Tenas Lake peat area

Tenas Lake is in secs. 2 and 11, T. 23 N., R. 4 W., about 3 miles northwest of Lilliwaup, which is on the northwest shore of Hood Canal. The unpublished soil map of Mason County (Ness et al.) shows 226 acres of Rifle peat along both sides of two branches of Lilliwaup Creek in secs. 2, 10, 11, 14, and 15, T. 23 N., R. 4 W. One of these branches receives the drainage from Tenas Lake. The peat touches the lake at the outlet, but elsewhere, although closely paralleling the southeast shore of the lake, it is separated from the lake by several hundred feet of hard land.

In 1948 it had been reported that this area was being drained so that peat could be produced. This region was visited by automobile over poor roads, and parts of it were explored on foot in July 1950. All parts that were reached were found to be covered with 1 to 3 feet of water, and all parts that could be seen from an old logging bridge and from a nearby height were flooded. Muck was found by digging in the shallow margin of the water, but no peat was found. Because of the water, it was impossible to bore any holes to test the depth and nature of the peat out in the main part of the area.

It seems unlikely that peat could be produced commercially here, but possibly if the land were cleared and drained it would be suitable for agricultural uses.

Price Lake peat area

The Price Lake peat area (124 acres) is in secs. 21, 22, and 23, T. 23 N., R. 4 W., about 2 miles northwest of the village of Lilliwaup, which is on the west shore of Hood Canal. The peat borders all of Price Lake but part of the north shore (map, fig. 105). It is mapped as Rifle peat on the unpublished soil map of Mason County (Ness et al.). A tributary of Lilliwaup Creek flows from the east end of the lake across a narrow neck of the peat and eventually reaches Hood Canal at Lilliwaup Bay.

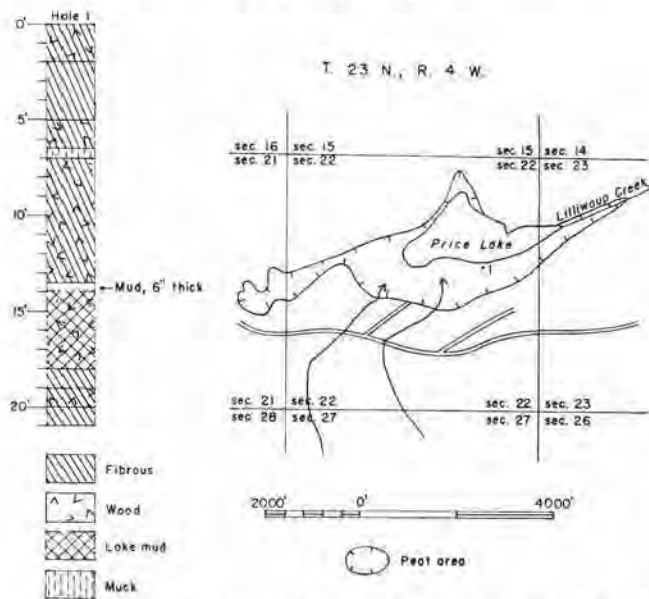

FIGURE 105.—Map and graphic log of a hole in Price Lake peat area (124 acres). Map adapted from U. S. Department of Agriculture unpublished soil map of Mason County and U. S. Army Map Service photomosaic.

The area at the south side of the lake is partly sphagnum bog and partly brushy swamp. A hole 6 feet back from the lake shore, near the float used by the resort owner for tying up rowboats, showed 21 feet of peat (fig. 105), but bottom was not reached because the peat was too compact to be bored deeper. The materials found are fibrous peat, woody peat, muck, and lake mud. The fibrous peat is light brown to reddish brown to dark brown, and varies from raw to disintegrated to decomposed. The muck is black. The color of the mixture of lake mud and woody peat is steel gray. There is some sphagnum mixed with the fibrous peat and woody peat in the upper 1 foot of this hole.

Isabella Lake peat area

Peat borders both the northeast and southwest ends of Isabella Lake. The unpublished soil map of Mason County (Ness et al.) shows 106 acres of Mukilteo peat at the southwest end and 69 acres of Mukilteo peat at the northeast end. The latter area was examined. It is in sec. 31, T. 20 N., R. 3 W., about 2 miles south of Shelton by way of a paved highway and a short graveled road which extends to within a few hundred feet of the peat (map, fig. 106). Mill Creek flows out of the lake across the peat to Hammersley Inlet.

The area is very wet and is covered with a swamp forest of alder, ash, willow, dogwood, and crab apple, in which there is an undergrowth of hardhack, wild rose, sedges, and mint.

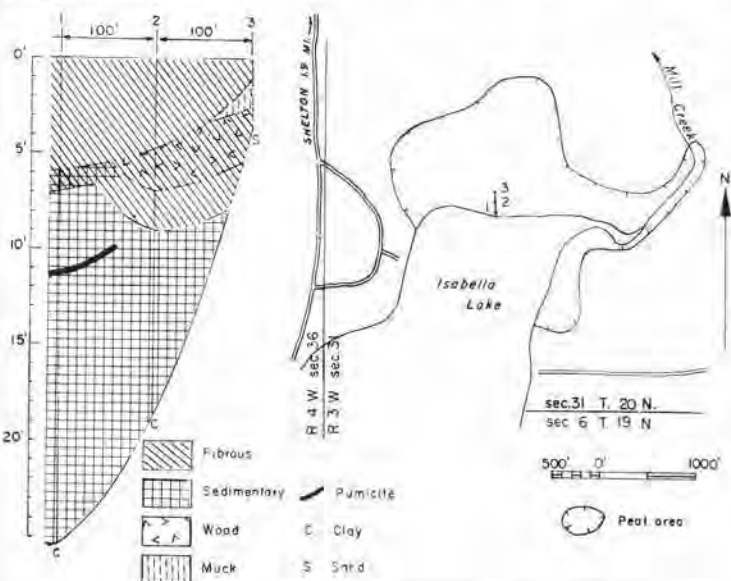

FIGURE 106.—Map and profile of Isabella Lake peat area (69 acres). Map adapted from U. S. Department of Agriculture unpublished soil map of Mason County and U. S. Army Map Service photomosaic.

The profile begins at the lake but does not extend to the north border of the peat. The deposit (fig. 106) consists mostly of fibrous and sedimentary peat, but there is some woody peat and some muck. The fibrous peat is brown to dark brown and ranges from disintegrated to decomposed. The sedimentary peat is olive brown. At hole 1 it rests on soft blue clay, at hole 2 on soft gray clay,

and at hole 3 on gray sand. White pumicite forms a layer ½ inch thick, 11 feet below the surface in hole 1.

Peninsula peat area

The Peninsula peat area (40 acres) is in secs. 2 and 11, T. 22 N., R. 3 W. It is about 7 miles by county road and a short private road southeast of Dewatto, a village on Hood Canal. Dewatto Bay is a harbor for small boats. The peat area is about 10 airline miles southwest of Bel-fair, but there is no direct road connection. There is a drainage ditch from the south end of the peat by which surplus water is removed to Rendsland Creek and thence to Hood Canal.

Before drainage and utilization were begun, this was a sphagnum bog with the usual flora of shrubs and herbs. The profile (fig. 107) is generalized from several borings

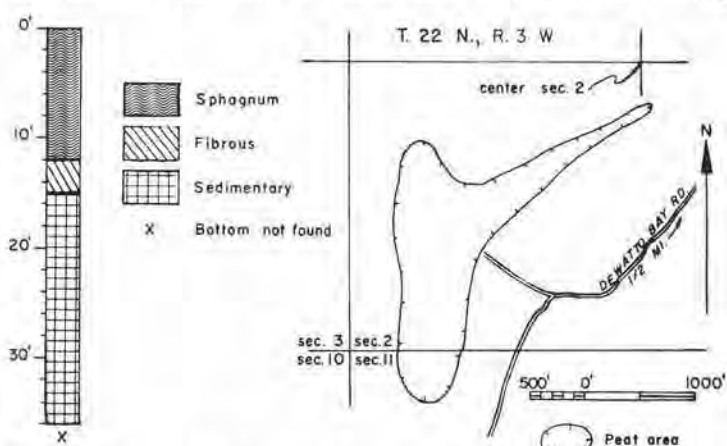

FIGURE 107.—Map and graphic log of a hole in Peninsula peat area, Mason County (40 acres). Map adapted from U. S. Department of Agriculture unpublished soil map of Mason County and U. S. Army Map Service photomosaic.

made in 1936 by G. B. Rigg and H. P. Hansen. The equipment available would not reach depths greater than 36 feet. No data on the total depth of the peat are available.

Sphagnum moss was being produced in 1950 by Peninsula Peat Producers, Inc., Tacoma, Washington. The locations of these excavations are shown on the map of the area (fig. 107). The company's investigations have confirmed the depth and character of the sphagnum moss as shown in the profile (fig. 107), and indicate that it extends over a considerable area of the bog. The upper layer is 6 feet deep and consists of whole stems with leaves attached. Under this is a 6-foot layer consisting mostly of pieces of stems and whole detached leaves. These factors, together with the good drainage, are favorable for production in this area.

J. M. Hoar peat area

The J. M. Hoar peat area (26 acres) is in sec. 28, T. 21 N., R. 2 W. It is just southeast of State Highway 14A (Shelton to Allyn), about 9 miles northeast of Shelton (map, fig. 109).

The peat lies in an undrained depression in glacial drift, but it could be ditched for drainage to the south through a tributary of Deer Creek. The southeastern part of the area is a sphagnum bog with a natural shallow



FIGURE 108.—Drying peat moss sods, Peninsula peat deposit, Mason County.

swampy sedgy marginal ditch around it. Living *Sphagnum* is abundant among the bog shrubs. There are several shallow meandering depressions in which there are almost pure stands of bog laurel. Coniferous trees, large and small (lodgepole pine, white pine, and hemlock), are common on part of the bog, and salal, young cascara trees, and fireweed also occur. The northeastern part of the area is shown as Mukilteo peat on the unpublished soil map of Mason County (Ness et al.).

The profile (fig. 109) shows a layer of sphagnum 2 to 3 feet deep which is raw at the surface but ranges through disintegrated to decomposed at the bottom of the layer. Much of the fibrous peat is raw, but some of it is decomposed. The color of the sedimentary peat varies from brown to dark olive green. The pumicite found at the 6-foot depth in hole 3 is brown. There is coarse sand and blue clay at the bottom of hole 1, blue clay at the bottom of hole 2, and coarse greenish-gray sand at the bottom of hole 3.

No evidence of any attempt at utilization was seen.

Grapeview Road peat area

The Grapeview Road peat area (24 acres) is in sec. 21, T. 21 N., R. 2 W. It is about 6 miles southwest of the village of Grapeview and about 10 miles northeast of Shelton by State Highway 14A (map, fig. 110).

This is a swampy area on which living *Sphagnum* grows among the stems of hardhack and swamp and aquatic herbs. Sedges, rushes, and water lilies are common.

The unpublished soil map of Mason County (Ness et al.) shows this as Mukilteo peat. Most of the peat found in the profile (fig. 110) is fibrous. It is raw and watery near the surface but ranges to disintegrated and compact at greater depths. The amounts of sphagnum peat, woody peat, and sedimentary peat are small. The deposit rests on blue clay.

No evidence of any attempt at utilization was seen. The peat lies in an undrained depression in glacial drift. The possibility of drainage was not investigated.

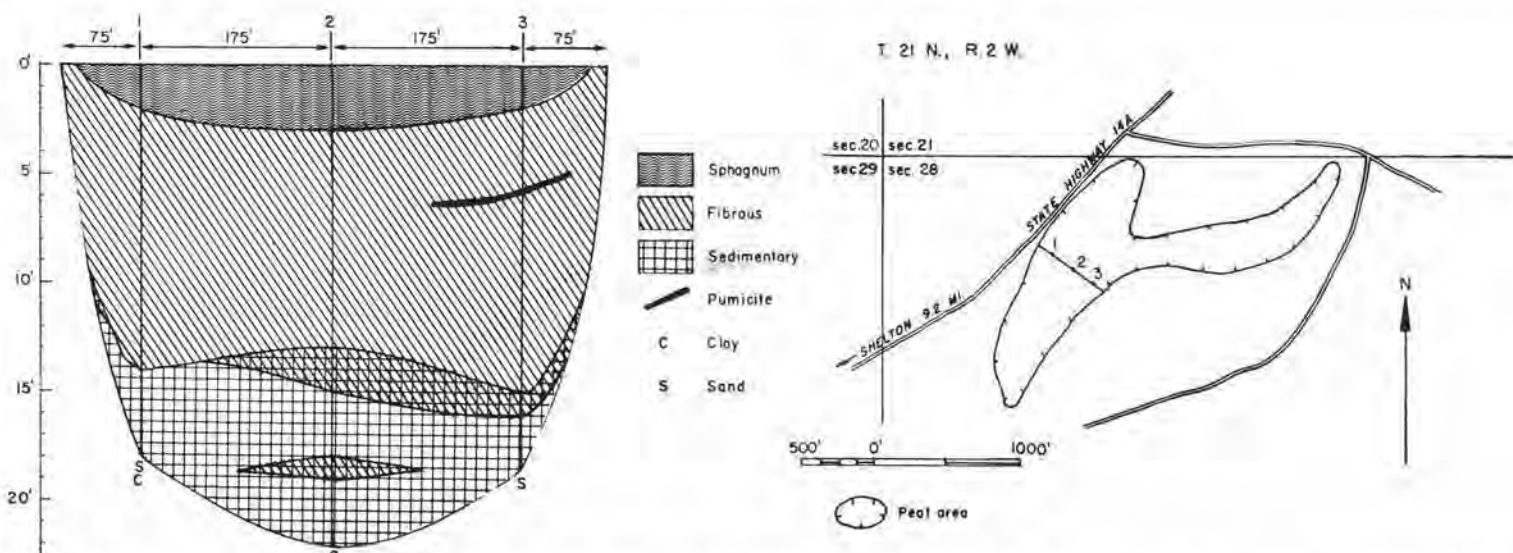

FIGURE 109.—Map and profile of J. M. Hoar peat area (26 acres). Map adapted from U. S. Department of Agriculture unpublished soil map of Mason County and U. S. Army Map Service photomosaic.

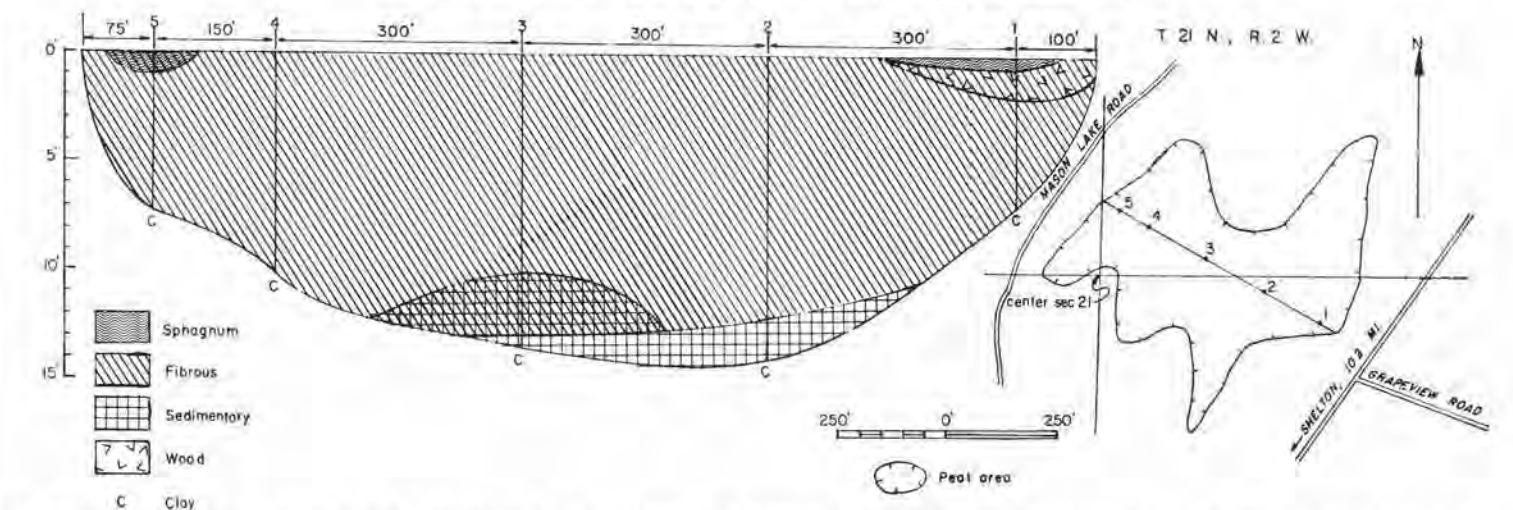

FIGURE 110.—Map and profile of Grapeview Road peat area (24 acres). Map adapted from U. S. Army Map Service photomosaic.

At Grapeview the average length of the growing season for the 31 years preceding 1941 was 209 days, and the average annual precipitation for the same period was 52.5 inches.

Lake Spencer peat area

The Lake Spencer peat area (23 acres) completely fills a long narrow arm of Lake Spencer. It is in sec. 32, T. 21 N., R. 2 W., about 7 miles northeast of Shelton. State Highway 14A (Shelton to Allyn) passes about 1/2 mile west of the peat area, and county and private roads give access directly to the peat (map, fig. 111). A drainage ditch extends across the peat to the lake. The peat area is shown as Greenwood and Mukilteo peat on the unpublished soil map of Mason County (Ness et al.).

This is a sphagnum bog covered with a growth of low bog shrubs with sedges in some places. Living *Sphagnum* is abundant, covering much of the surface and forming hummocks around the shrubs. The scattered trees on the bog are mostly lodgepole pine, ranging from seedlings to

trees 20 feet tall, but there are a few yellowish sickly looking Douglas firs.

The amount of sphagnum revealed in the profile (fig. 111) is large, and some of it is of good quality and is quite free from the remains of other plants. Some of it, however, is mixed with fibrous peat, some with wood peat, and some with both. Some of the sphagnum, in which no mixture with other plant remains is shown in the profile, is actually irregularly mixed in some places with twigs and the remains of fibrous plants and mosses other than *Sphagnum*. Some of it is disintegrated, and some is decomposed.

The fibrous peat is brown, and the sedimentary peat is olive colored. The peat is strongly acidic, and the acidity decreases gradually with depth. It ranges from pH 3.0 at the 1-foot depth to pH 5.0 at 18 feet. This decrease in acidity with increasing depth is common in peat deposits in Washington. The deposit rests on clay which is gray at hole 1, greenish gray at holes 2, 3, and 4, and black at hole 5, where it is mucky.

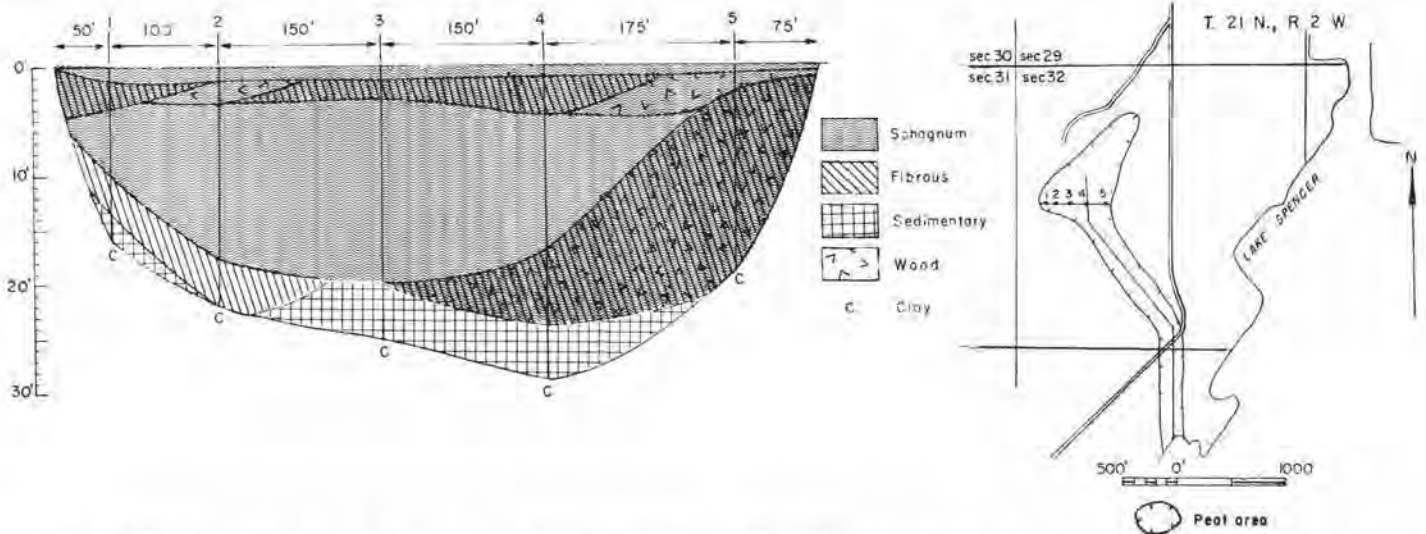

FIGURE 111.—Map and profile of Lake Spencer peat area (23 acres). Map adapted from U. S. Department of Agriculture unpublished soil map of Mason County and U. S. Army Map Service photomosaic.

The production of peat moss (sphagnum) was attempted here some years ago, and a shelter was built for storing it, but the project was abandoned. It is quite possible that peat moss could be successfully produced here, but more borings should be made at several places in the bog before making any large investment in it.

Drainage Ditch peat area

The Drainage Ditch peat area (23 acres) is in sec. 5, T. 19 N., R. 3 W., about 3 miles south of Shelton and a few hundred feet east of U. S. Highway 101. A large drainage ditch, by which water reaches Skookum Inlet, extends along its northeast border (map, fig. 112). The peat lies in a depression in glacial drift. It is mapped on the unpublished soil map of Mason County (Ness et al.) as Mukilteo peat.

This is a sphagnum bog with a zone of hardhack, crab apple, and cascara around most of its margin. Labrador tea is the most abundant shrub in the bog. The small creeping woody vines of the native cranberry are common. Herbaceous bog plants are abundant. Among them is the tall bog gentian which has showy blue flowers. Reed canary grass is established in some places.

The peat shown in the profile is mostly fibrous and sedimentary (fig. 112). The layer of sphagnum is thin, and woody peat is found only in hole 1. The fibrous peat is mostly disintegrated, but some of it is raw. Much of it is wet, and some is watery. The sedimentary peat is olive to brown and is compact at the bottom of holes 2 and 4. A ¼- to ½-inch layer of pumicite was found at only three of the five holes in the profile; it is brown in holes 1 and 5 and white in hole 3. The peat is strongly acidic, and its acidity changes only slightly with depth. In hole 3 the pH at the depths listed is: At 1 foot, 4.5; at 6 feet, 4.5; at 11 feet, 4.2; at 20 feet, 4.4; and at 30 feet, 4.3.

The drainage ditch in the northeastern part of the peat is wide and deep, but its depth (perhaps 12 or 15 feet) is not great enough to remove water from the deeper part of the peat (27 to 31 feet). It seems probable that water continues to come up by inhibition and capillarity through

the peat from some abundant source of water at the bottom of the deposit.

Hole 5 is in a pasture, but the peat there is only 8 feet deep, and there is a strip 100 feet wide of crab apple and hardhack between holes 4 and 5. Evidently the drainage ditch has somewhat lowered the water content of the peat near the surface of the main part of the sphagnum area, but plants characteristic of wet sphagnum bogs still grow there. The reed canary grass growing there does not seem to be of any economic importance.

C.C.C. Project Number 5 peat area

The peat area (19 acres) on the former Civilian Conservation Corps Project Number 5 is in secs. 29, 30, 31, and 32, T. 20 N., R. 5 W. It is about 20 miles by road west of Shelton and about 5 miles southeast of Matlock, in a logged-off area owned by the Simpson Logging Company, of Shelton. A county road extends through the logged area, and an old logging road extends to the immediate vicinity of the peat. A bridge on this logging road was out in 1950, and the only access to the peat was by walking.

This undrained sphagnum bog lies in a depression in glacial drift. It is surrounded by a shallow natural marginal ditch in which crab apple trees and hardhack and other shrubs grow. There are fewer trees on this bog than is usual on sphagnum bogs in western Washington. There are some small cascara trees and a few stunted cedars. Some old snags of larger coniferous trees are still standing. The usual bog shrubs are common. A showy prairie lily, resembling a tiger lily, is abundant, and this is rare in sphagnum bogs. Bracken ferns also occur. Sedges and other wet-ground species are abundant. Water lilies and other aquatic plants occur, especially in numerous small natural depressions 1 to 2 feet deep. Living *Sphagnum* is abundant on most of the bog.

This bog is shown on the unpublished soil map of Mason County (Ness et al.) as Greenwood peat, and another Greenwood peat area of about the same size is shown about 500 feet to the northeast.

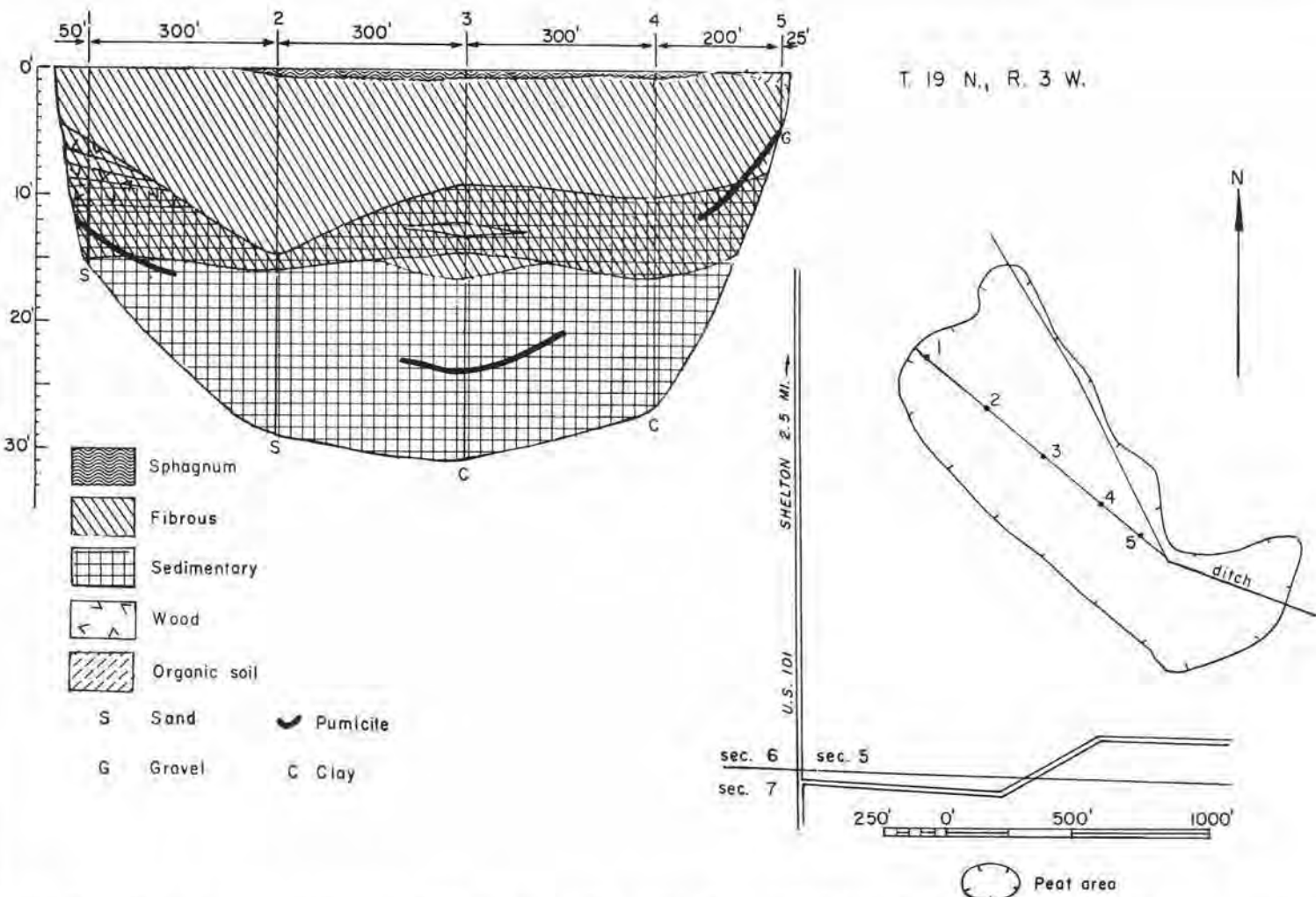

FIGURE 112.—Map and profile of Drainage Ditch peat area (23 acres). Map adapted from U. S. Department of Agriculture unpublished soil map of Mason County and U. S. Army Map Service photomosaic.

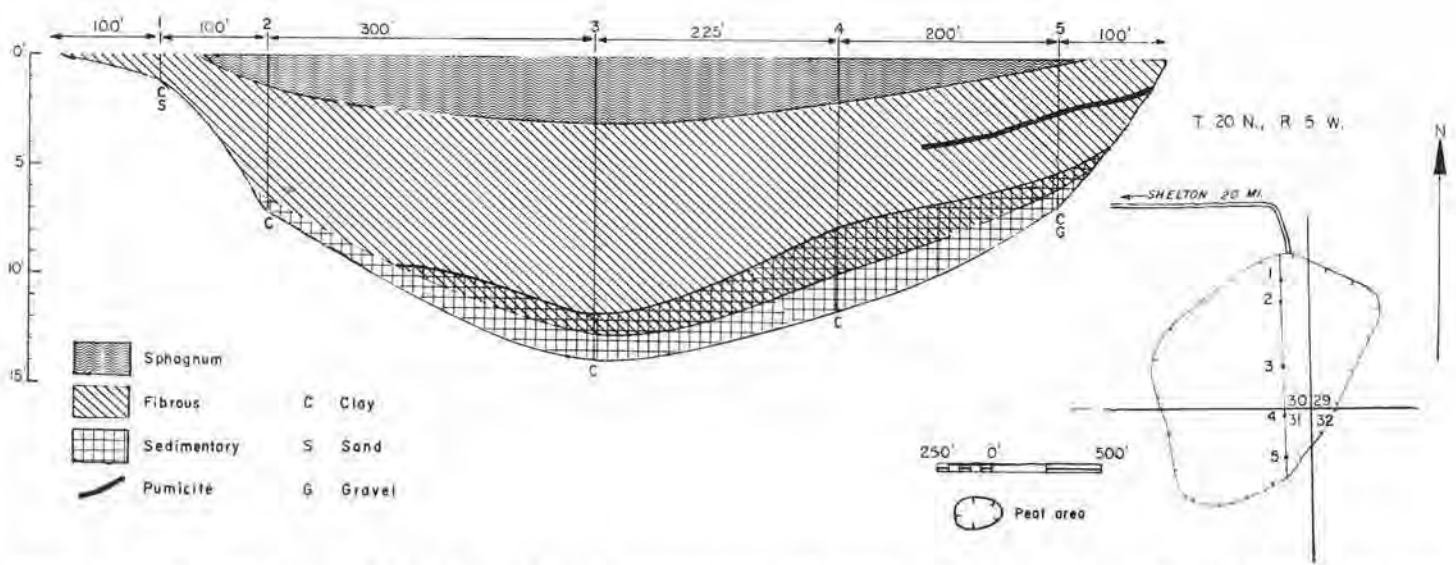

FIGURE 113.—Map and profile of C.C.C. Project Number 5 peat area (19 acres). Map adapted from Simpson Logging Co. map.

The profile (fig. 113) shows sphagnum, fibrous peat, and sedimentary peat. The 1-inch layer of pumicite revealed in hole 5 is brown. The sphagnum is of good quality and is light brown to brown in color. The fibrous peat is light brown to brown and ranges from disintegrated to decomposed. The sedimentary peat is olive brown to brown. It rests on blue clay.

There is enough good sphagnum in this bog for local use, but not enough to justify commercial development under present conditions.

Tiger Lake peat area

The Tiger Lake peat area (17 acres) is in secs. 5 and 8, T. 23 N., R. 1 W., about 5 miles north of Belfair. A county road crosses the peat, and branches of this road extend along parts of both margins (map, fig. 114). The peat does not border the lake, but lies in a depression in glacial drift a few hundred feet west of the lake. There is a drainage ditch in the bog, from which the water eventually reaches Hood Canal by way of Mission Creek.

This is a brushy peat area. The growth of hardhack is very dense, although there are sedges in some places. No *Sphagnum* was seen. The area is mapped as Mukilteo peat on the unpublished soil map of Mason County (Ness et al.).

The peat in the upper part of the profile is all fibrous, and in the lower part it is a mixture of fibrous and sedimentary (fig. 114). Most of the peat is brown. The pumicite in hole 1 is brown, and in hole 2 it is yellow. It varies in thickness from ½ inch to 2 inches.

Some of this peat is wet but not excessively so. None of it found in the borings was dry. Gravel was found at

the bottom of hole 1. The peat at the bottom of hole 2 was too compact to be penetrated deeper. The ditch indicates that some attempt at utilization has been made, but no other evidence of attempted utilization was seen.

Wivell Farm peat area

The Wivell Farm peat area (13 acres) is in sec. 10, T. 19 N., R. 4 W., about 7 miles by road southwest of Shelton. It is in Gosnell Creek Valley. The creek flows northward just west of the peat (map, fig. 115). A drainage ditch within the peat area roughly parallels the length of the area and leads to Gosnell Creek. The land rises abruptly on the east side of the area. The peat area is used for pasture and is surrounded by a hayfield, in which some skunk cabbage grows with the grasses. The area is shown as Mukilteo peat on the unpublished soil map of Mason County (Ness et al.).

The organic matter (18 feet deep) is mostly muck and woody peat (fig. 115). The fibrous peat is dark brown and disintegrated, the muck is brown. The peat is rather weakly acidic (pH 5.0 to 4.8). It rests on coarse gray sand in which some wood is mixed.

C.C.C. Project Number 13 peat area

The peat area (5 acres) on the former Civilian Conservation Corps Project Number 13 is near the center of sec. 28, T. 20 N., R. 5 W., about 19 miles west of Shelton by road. It is in the valley of the East Fork of the Satsop River, and probably is more or less representative of at least four similar, but somewhat larger, areas of Mukilteo peat within a radius of 1 mile, as shown on the unpublished soil map of Mason County (Ness et al.).

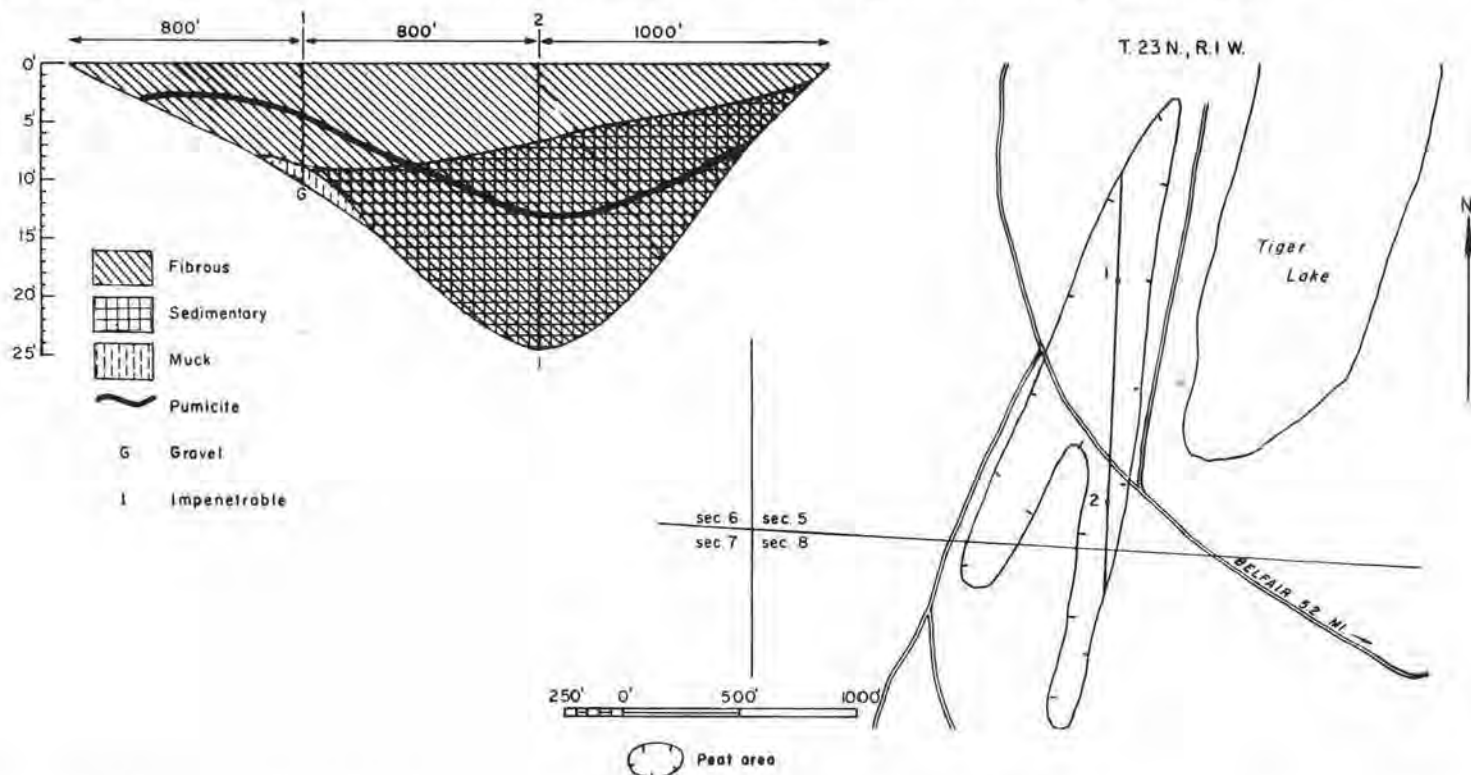

FIGURE 114.—Map and profile of Tiger Lake peat area (17 acres). Map adapted from U. S. Department of Agriculture unpublished soil map of Mason County and U. S. Army Map Service photomosaic.

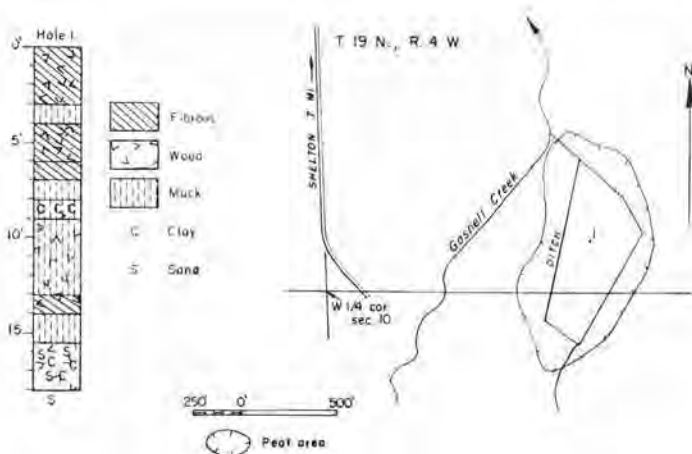

FIGURE 115.—Map and graphic log of a hole in Wivell Farm peat area (13 acres). Map adapted from U. S. Department of Agriculture unpublished soil map of Mason County.

In the area examined, the peat is the dry and partially burned remains of what evidently was formerly a flourishing bog. There are several low "islands" of sand and gravel in it, but they are not shown on the map. The vegetation now growing is composed of hardhack and sedges with a few dying cattails.

In the central part of the area there is fibrous peat 4 to 4½ feet deep. In color it ranges from reddish brown to dark brown, and in degree of humification it ranges from disintegrated to completely decomposed.

Belfair peat area No. 1

Belfair peat area No. 1 (5 acres) is in sec. 28, T. 23 N., R. 1 W., about 1 airline mile northeast of Belfair. It is about 1 mile south of the point where State Highway 14A crosses from Mason County to Kitsap County. A private road extends to the area. The peat lies in a shallow undrained depression in glacial drift.

The characteristic vegetation in the central part of the area is composed of rushes and sedges with some *Sphagnum* (mostly dead), and around the margin, hardhack brush. The area is shown as Greenwood peat on the unpublished soil map of Mason County (Ness et al.).

Some peat was produced from this area by the Puget Moss and Fertilizer Company, but the project was abandoned in 1948. Peat was removed by the use of a Bagley-type scraper drawn across the peat by a cable.

The material exposed in the banks of the ditch dug by the scraper is fibrous peat 1½ to 5 feet deep with a few inches of moss peat (*sphagnum*) at the surface.

Belfair peat area No. 2

Belfair peat area No. 2 (5 acres) is in secs. 12 and 13, T. 23 N., R. 2 W., about 3½ airline miles northwest of Belfair. An unimproved road extends north and south near the west border of the peat, the nearest point being about 100 feet distant. The peat lies in an undrained depression in glacial drift.

This is a very wet *sphagnum* bog in an early stage of development. Water 1 to 2 feet deep stood on it in July 1950, and the vegetation was composed of Labrador tea,

sundew, *Sphagnum*, St. John's wort, hardhack, willow, and crab apple.

The peat is 10 feet deep in the central part of the area. *Sphagnum* peat 2 feet deep overlies 1 foot of mixed fibrous and sedimentary peat and 7 feet of sedimentary peat which rests on dark-gray coarse sand. The *sphagnum* is dark brown, disintegrated, and watery. The fibrous peat is light brown and decomposed. The sedimentary peat is light olive green and contains some fibers.

Belfair peat area No. 3

Belfair peat area No. 3 (5 acres) is in secs. 10 and 15, T. 23 N., R. 2 W., about 7 miles northwest of Belfair. The road to Belfair passes within 100 feet of the north end of the peat, and an unimproved road ends about 200 feet east of the east border. The peat lies in an undrained depression in glacial drift.

All this peat area is very wet. In July 1950 most of it was flooded. There was an open pond bordering the north end, and at the center of the peat area the water was 18 inches deep. The whole area is shown as a lake on most maps. Sedges and other erect aquatic plants projected above the water. The hard land slopes steeply down to the margin of the peat.

The deposit is 10 feet deep. It consists of two 4-foot layers of sedimentary peat with a 2-foot layer of fine fibrous peat between them. A 1-inch layer of brown pumicite is at the 5-foot level. The peat rests on gray sand.

Belfair peat area No. 4

Belfair peat area No. 4 (4 acres) is in sec. 1, T. 23 N., R. 2 W. It is about 6 miles northwest of Belfair by a road which passes close to the eastern border of the peat. This peat appears to be representative of a compact group including at least four other peat areas of about equal size, all in shallow depressions in glacial drift and all within 900 feet of the area examined.

Sphagnum and pigeon wheat moss grow vigorously around the margin of the peat. In the central part, hardhack and sedges grow in a substrate consisting mainly of dead *Sphagnum*, but no living *Sphagnum* was found. Apparently the bog is now much drier than it has been in the past. This may be due to logging of the surrounding land.

The deposit is 5½ feet deep. The peat moss (*sphagnum*) which constitutes the upper 3 feet is brown and disintegrated. Under the *sphagnum* is 1 foot of fibrous peat that is dark brown and disintegrated, and under this is a 2-foot layer of a brown mixture of sedimentary peat and fibrous peat. A layer of brown pumicite 2 inches thick is at the 2½-foot level. The deposit rests on yellowish-gray coarse sand.

Shoe Lake peat area

The Shoe Lake peat area (4 acres) is in secs. 25 and 36, T. 23 N., R. 3 W., about 3 miles east of Dewatto, which is on Hood Canal. The peat borders the west end of Shoe Lake (map, fig. 116). It is reached by road from Dewatto and also (5½ miles) from Tahuya.

The part near the lake is a *sphagnum* bog, on which there is a dense growth of coniferous trees. These are mostly lodgepole pine, some of which are as much as 30

feet tall. There are also some white pine and some hemlock. Sedges and water lilies are abundant along the lake margin. Labrador tea, bog laurel, and native cranberry grow on the bog. In the vicinity of holes 2, 3, and 4 of the profile there is a sedge meadow on which there is some standing water, and there is hardhack at the border. The land near the lake and the peat rises abruptly.

The peat (fig. 116) is deep (21½ feet) near the lake but is shallow (1 foot) at the southwest end. The sphagnum

depression in glacial drift and is shown as Mukilteo peat on the unpublished soil map of Mason County (Ness, et al.). This is mostly a hardhack swamp in which some *Sphagnum* grows. There is a pond at the north end. The peat deposit consists of 2 feet of brown fibrous peat and 8 feet of light olive green sedimentary peat. The latter is compact at the bottom and rests on coarse sand.

Cranberry Lake peat areas

Cranberry Lake is a shallow body of water about 1½ miles long and ¼ mile wide lying in a depression in glacial drift. It is 5 miles north of Shelton and may be reached at several points by unsurfaced roads which connect with paved highways. Several small streams flow into the lake, but apparently there is no surface outlet.

The unpublished soil map of Mason County (Ness et al.) shows a total of 255 acres of Greenwood, Rifle, and Mukilteo peat in seven separate areas around the borders of the lake. There are 64 acres of Rifle, 87 acres of Mukilteo, and 104 acres of Greenwood peat. The Greenwood is in two areas, one of 19 acres at the south side of the lake near its west end, and the other of 85 acres extending half a mile westward from the west end of the lake. Near the lake shore this area is covered with the usual sphagnum bog flora, and good sphagnum peat extends to a depth of at least 1 foot. No holes were bored, so the depth of the peat is not known, but there may be a large amount of sphagnum peat as well as much fibrous peat here at Cranberry Lake.

Oakland Bay tidelands

An extensive tideland area is in secs. 2, 3, and 10, T. 20 N., R. 3 W., at the head of Oakland Bay about 3 miles northeast of Shelton. It is a salt marsh, mostly of the grassy type, in which salt grass is the dominant plant. There is some glasswort (samphire) in places, and some sedges grow near the margin.

Observations on the banks of meandering channels in the marsh and investigations by digging at several places show 15 to 20 inches of raw fibrous peat which has evidently originated from salt-marsh plants. It rests on sand and gravel.

OKANOGAN COUNTY DEPOSITS

Bonaparte Meadows peat area

The Bonaparte Meadows peat area (282 acres) is in secs. 16, 17, 20, 21, and 29, T. 38 N., R. 30 E., about 4 miles north of State Highway 4 (Tonasket to Republic). It is about 18 airline miles northeast of Tonasket but is considerably farther by highway. An improved road extends north from State Highway 4 to Bonaparte Meadows and Bonaparte Lake (map, fig. 117). The meadows are about 4 miles northwest of Wauconda, which is north of Highway 4. The meadows and the lake are in the Okanogan Highlands at an elevation of 4,600 feet above sea level. The depression in which they lie is elongated north and south and was probably formed by the damming of Bonaparte Creek Valley by glacial drift. Bonaparte Creek flows south from the lake through the meadows to the Okanogan River at Tonasket. There are two ponds in the

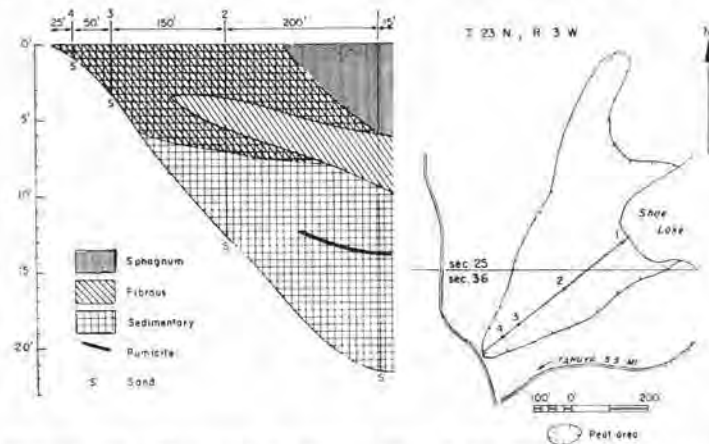

FIGURE 116.—Map and profile of Shoe Lake peat area (4 acres). Map adapted from U. S. Army Map Service photomosaic.

num near the lake is 6 feet deep and is light brown and of good quality, though rather watery. The fibrous peat is brown and disintegrated. The sedimentary peat is olive green to olive brown and is mostly soft. The 1-inch layer of pumicite in hole 1 is white. The peat rests on greenish-gray sand.

Peat area west of Price Lake

A peat area (4 acres) about 1 mile west of Price Lake is in sec. 21, T. 23 N., R. 4 W. It is an irregular zone, 50 feet or more in width, surrounding a pond which is about 250 feet wide and 400 feet long.

This area is very wet. Part of it is a sphagnum bog with the usual growth of living *Sphagnum* and bog shrubs and herbaceous plants, and part of it is swamp with hardhack in some places and swamp and aquatic herbs in others.

In a shrub area south of the pond is 1 foot of fibrous peat with many living roots of shrubs, underlain by 1 foot of fibrous peat mixed with woody peat. Under this is woody material which is too compact to be penetrated with the peat borer. In the sphagnum bog west of the pond the organic matter is 6 feet deep and rests on gravel. There is 1 foot of sphagnum at the top. Under this is a 2-foot layer of fibrous peat, then 1 foot of mixed fibrous and sedimentary peat, 1 foot of sedimentary peat, 8 inches of fibrous peat, and 4 inches of muck resting on gravel.

Tee Lake peat area

The Tee Lake peat area (3 acres), about ½ mile east of Tee Lake, is in sec. 36, T. 23 N., R. 3 W., about 5 miles northeast of Tahuya and about 3 miles southeast of Dewatto. The road to Tahuya passes close to the southeast border of the area. The peat lies in a shallow undrained

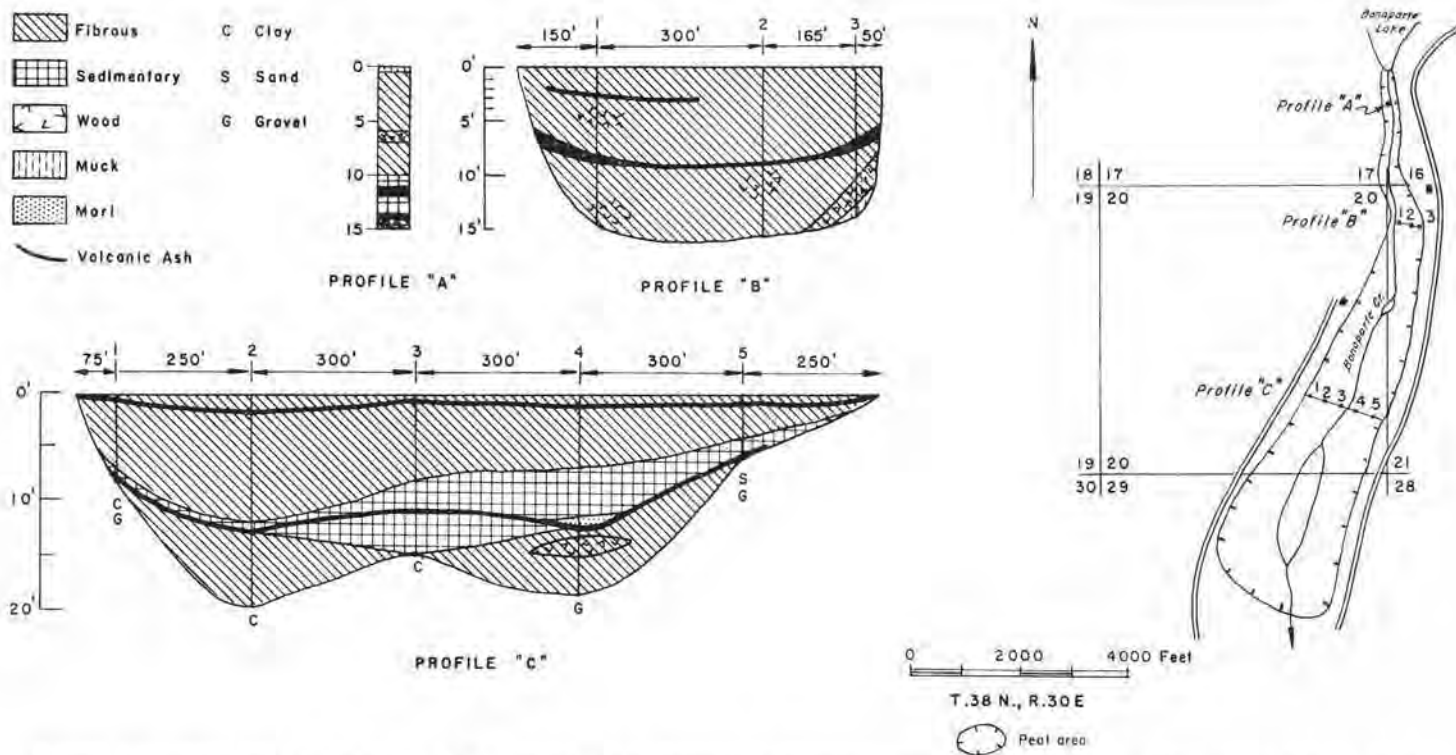

FIGURE 117.—Map, profiles, and graphic log of a hole in Bonaparte Meadows peat area (282 acres). Map adapted from U. S. Geological Survey topographic map (Osoyoos quadrangle).

meadow, and there was some standing water on the meadow in July 1949.

The meadow is covered with a dense growth of sedges about 3 feet tall, and there are aquatic plants in some places.

The peat shown in the three profiles (fig. 117) is 15 to 20 feet deep and is mostly fibrous. The sedimentary peat, however, is 7 feet deep in one hole. There is some woody peat and a small amount of muck. Some marl occurs at the bottom of the one hole in profile A, and also just above the layer of pumicite in hole 4 of profile C. The fibrous peat is light brown to dark brown. Part of it is raw and part is decomposed, and some is watery. The sedimentary peat is olive brown to olive green. Pumicite is present in all holes in all profiles and forms an unusually thick layer (up to 1 foot) in some holes. It is white to whitish gray in color. In all holes in profile C two layers of pumicite were found. The deposit rests on gray clay, coarse sand, and gravel.

The presence of wire fences suggests that the meadows have been used as pastures.

At Oroville, which is about 26 airline miles northwest of this peat, the average length of the growing season for the 24 years preceding 1941 was 157 days, and the average annual rainfall for the 25 years preceding 1941 was 10.61 inches.

Bonaparte Lake peat area

The Bonaparte Lake peat area (roughly estimated as 10 acres) is in sec. 9, T. 38 N., R. 30 E. It borders the north end of the lake. It was covered with water at the time it was visited (July 1949), so that the boundaries could not

be determined. The level of the lake is controlled by a dam at the south end.

The peat is covered with swamp and aquatic vegetation. Two feet of standing water covered the ground at hole 1 of the profile, and hole 2 was bored on a beaver dam which had ponds on both sides of it.

The peat is mostly either fibrous or woody. In hole 1, bored 30 feet northeast of the northeast end of the lake, fibrous peat extends from the surface to the 5-foot depth. Under this is 1 foot of white pumicite, underlain by 1 foot of mixed marl, sand, and gravel, which rests on sand and gravel. Farther from the lake, 60 feet northeast of hole 1 is hole 2, where wood peat extends from the surface to the 1-foot depth. Under this is 3 feet of fibrous peat, 3 feet of wood peat, 1 foot of fibrous peat, 1 foot of wood peat, and 2½ feet of fibrous peat resting on sand and gravel.

Hansen (1947) bored the peat in the vicinity of Bonaparte Lake to obtain fossil pollen for his study of forest succession, climate, and chronology. He found 3.2 meters (10 feet 6 inches) of sediments with a layer of pumicite at 1.8 meters (6 feet 4 inches).

Aeneas Valley

Aeneas Post Office, which is in Aeneas Valley, is in sec. 8, T. 35 N., R. 31 E. A dirt road extends through the valley from a point on State Highway 4, about 1 mile west of Leese, to a point, also on State Highway 4, about 10 miles south of Republic. The valley trends from northwest to southeast. It is about 15 miles long, and much of it is ¾ mile wide. Aeneas Creek flows northwestward through the northwest part of the valley to Bonaparte Creek. In the southeast part of the valley the West Fork of the Sanpoil River flows southeastward to the Sanpoil River.

Both streams are sluggish. The borders of the valley contain prominent terraces composed of sand, gravel, and silt.

The only hole bored in this valley is in the SE $\frac{1}{4}$ sec. 9, about 1 $\frac{1}{2}$ miles southeast of Aeneas Post Office. It shows 5 feet of dark-brown disintegrated fibrous peat which is weakly acidic (pH 6.5). Under this is 2 feet of a mixture of dark-brown muck and coarse sand. There is a 1-inch layer of sand between this mixture and the overlying fibrous peat. Under the mixture is dark-brown clay and fine sand. The vegetation at the hole consists of sedges, cattails, knotweeds, marsh fivefinger, willows, and small peat-bog birch trees.

No indication of any important peat in this valley was found.

Mount Hull peat areas

There are three small peat areas totaling about 11 acres on Mount Hull (elevation 4,600 feet), in the Colville National Forest, about 5 miles southeast of Oroville. They are reached by dirt roads.

The largest of the areas, Big Mack "lake" (9 acres, estimated), is in the SE $\frac{1}{4}$ sec. 10, T. 39 N., R. 28 E., about 1 mile northwest of and 400 feet in elevation higher than the end of a logging road near the center of sec. 14. A very poor trail extends from the end of the road to the peat area.

This "lake" is really only a wet bog, which was covered by water to an average depth of 1 foot in August 1942, when it was inspected by a geologist of the Division of Geology. The water could be drained easily by digging a short ditch of shallow depth. The area is estimated to be 400 feet wide by 1,000 feet long.

A sample of the peat from near the surface at a point 40 feet from the north shore and 150 feet from the east end showed decomposed peat, in which there is a thin layer of pumicite. No borings were made during either the 1942 or 1950 inspection, but Mr. A. T. Scott of Omak, who once owned the bog, reported that he had found peat at the bottom of a 30-foot hole he had bored.

The next largest area (Bear Paw bog) is in sec. 20, T. 39 N., R. 28 E. It is about 350 feet long by 150 feet wide and lies within 100 feet of the Mount Hull Lookout road. It occupies a depression behind a bouldery moraine. Its surface is wet, even in summer, but it could be drained easily by a short shallow ditch. Its vegetation consists of sedges, pondweed, and water plantain.

The deposit consists of 7 feet of dark-brown decomposed fibrous peat and 6 inches of olive-colored sedimentary peat which rests on fine gray sand. Two layers of pumicite are present at depths of 1 foot and 4 feet. The upper layer is white and is $\frac{1}{2}$ inch thick; the lower layer is brown and is 4 inches thick.

A smaller peat area is in sec. 17, T. 39 N., R. 28 E., and is 0.7 mile north of Bear Paw bog and about 100 feet east of the Mount Hull Lookout road. There was 18 inches of standing water on it in August 1950. The vegetation consists of sedges, scouring rush, and water plantain.

The deposit consists of 8 feet 8 inches of dark-brown fibrous peat, decomposed at the top and disintegrated at the bottom. The upper 1 foot of this is mixed with sedimentary peat. A layer of brown pumicite 2 inches thick

was found at a depth of 5 $\frac{1}{2}$ feet. The deposit rests on a mixture of gray clay and fine sand.

PACIFIC COUNTY DEPOSITS

PENINSULA PEAT AREAS

These peat areas (estimated total between 3,000 and 4,000 acres) are all on the sandy peninsula bounded on the west by the Pacific Ocean, on the east by Willapa Bay, and on the south by Baker Bay, which is a part of the broad mouth of the Columbia River. The peninsula extends 22 miles northward from North Head, near the mouth of the Columbia River, and is from 1 to 2 miles wide. An isthmus about 3 miles long and 4 to 5 miles wide connects the peninsula with the mainland and lies between Baker Bay and the head of Willapa Bay. It is composed mostly of silty clay and silty clay loam. The soils of the isthmus and the peninsula are shown on a published map, the soil survey of Southwest Washington (Mangum et al., 1913).

All but one of the peat areas are narrow and elongated and lie between sand ridges extending north and south. These ridges are a series of low rounded stabilized dunes, none of which reach a height of more than 50 feet above sea level. There are many elongated lakes between these dune ridges, and some of the peat areas border the lakes.

The exception mentioned above is the peat area about 2.8 miles long and 0.8 mile wide which lies between the sand of the peninsula and the silty clay of the isthmus. It lies east of Seaview, and its southern end is about 0.5 mile north of Ilwaco. It borders the north end of Black Lake. Water moves sluggishly northward through the western part of the peat through Tarlatt Slough (Martin River) to Willapa Bay. In the following discussion this bog is included with the others under the term "peninsula bogs" except where specifically designated otherwise.

Many of the peninsula peat areas are sphagnum bogs. *Sphagnum* is growing in them, and their vegetation consists of the usual bog shrubs and herbaceous species. However, some of the areas in which *Sphagnum* grows are characterized mainly by shrubs such as hardhack and sweet gale and by swamp and aquatic species such as sedges, rushes, cattails, scouring rushes, and water celery. Coniferous trees and some alder, willow, and cascara trees occur in some of them. Some of the areas, however, have no *Sphagnum*, and the plants growing on them are mainly sedges. Many of the bogs have been modified or even completely changed by drainage, clearing, and burning.

There is coniferous forest of spruce, cedar, and hemlock on a considerable portion of the stabilized dune area of the peninsula. Some of this area has been logged, and some logging is still going on. There are lodgepole pine trees in the region of the moving dunes and elsewhere.

The climate of the peninsula is oceanic. None of the bogs are more than 1 mile from the ocean. At North Head (elevation 194 feet) records for 36 years prior to 1941 show that the average length of the growing season is 297 days and that the annual precipitation is 50.85 inches. However, these records indicating a long growing season are not applicable to the nearby bogs back of the line of ocean dunes at an elevation of 10 or 15 feet above sea level. Superintendent D. J. Crowley of the State College

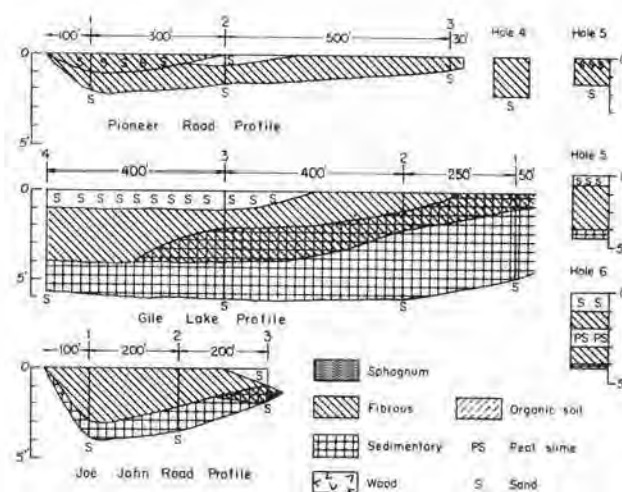
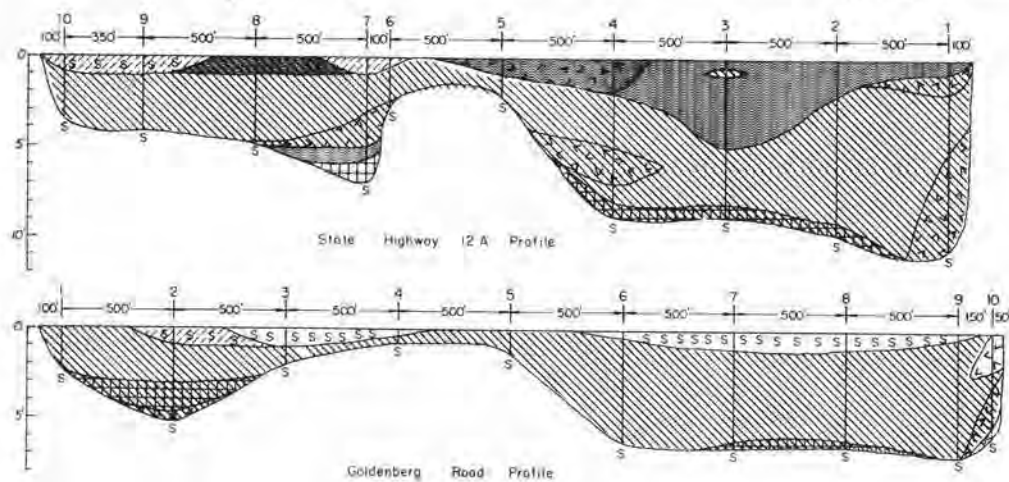
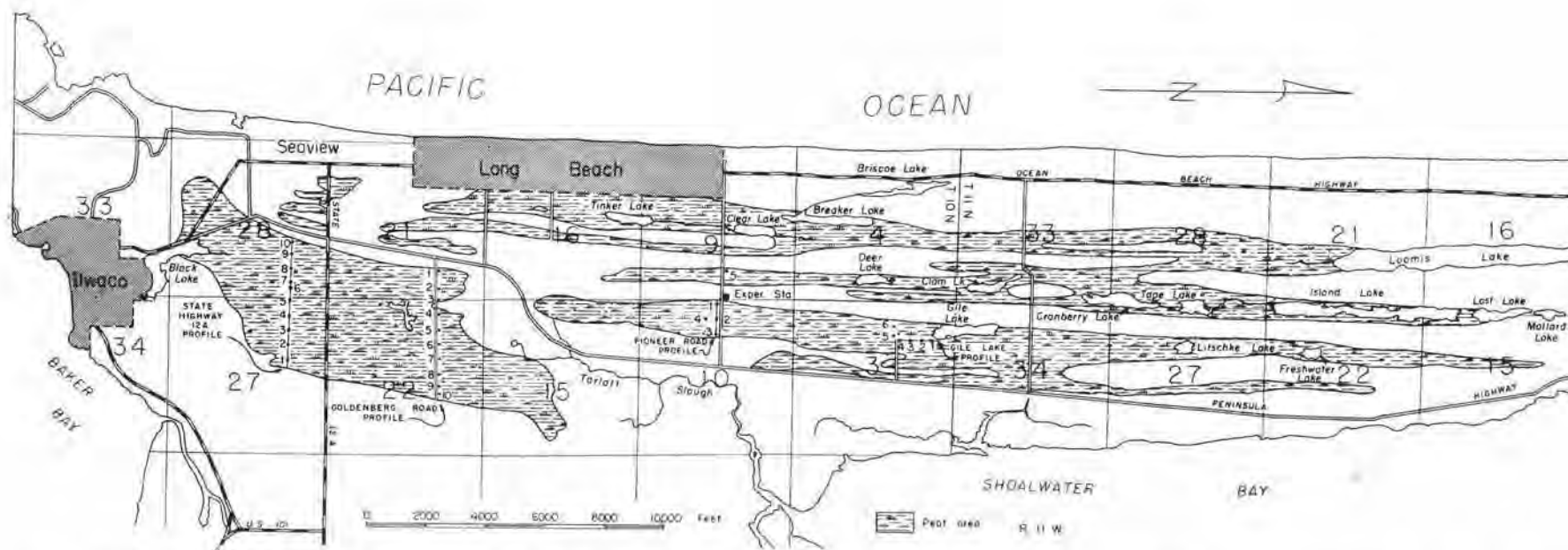

FIGURE 118.—Map and profiles of Peninsula peat areas, Pacific County (3,000 to 4,000 acres, estimated). Map adapted from U. S. Soil Conservation Service soil map and U. S. Army Map Service photomosaic.

Cranberry-Blueberry Experiment Station at Long Beach stated in a personal communication that during the past 30 years there have been frosts on the peat bogs in practically every month of the year, and at least one killing frost occurred as late as July 6. Prior to the use of the sprinkler system for frost control, frost injury to some of the cranberries in either May or June was common.

On the basis of an estimated 3,000 to 4,000 acres of peat on the peninsula, between 11 and 14 percent of the total area is peat. The number of bogs is large, and there are not enough data available to describe each of them or to state the depth and character of the peat in each. Specific information is available, however, from five profiles and the plant communities along them. Two of these (State Highway 12A profile and Goldenberg Road profile) are in the broad bog near Seaview. The other three are in the narrow bogs in the sandy region farther north. The northernmost one (Joe John Road) is about 12 miles north of the southernmost (State Highway 12A). Field work at various times in the years since 1908 indicates that these profiles are representative of the bogs of the peninsula.

In 1952, of the 3,000 to 4,000 acres of peat land in the peninsula area, 400 or 500 acres were devoted to commercial cranberry culture, and about 50 acres to blueberries.

The map (fig. 118) shows only the south half of the peninsula, but the mapped part includes at least three-fourths of the peat area on the peninsula. One profile (Joe John Road profile) is in the north half, not shown on the map.

State Highway 12A profile

State Highway 12A extends along the north line of secs. 27 and 28, T. 10 N., R. 11 W. The profile (4,150 feet long) extends from east to west, parallel with the highway and 0.2 mile south of it (map, fig. 118).

The profile starts in an open forest of spruce, hemlock, and cedar which has an undergrowth of evergreen huckleberry, skunk cabbage, and deer fern. A thick carpet of forest duff covers the ground. This forest in a short distance merges into a sphagnum bog which has the usual growth of bog shrubs, including bog laurel and two species of Labrador tea (*Ledum groenlandicum* and *L. columbianum*). On the bog are some trees (spruce, lodgepole pine, cascara, and alder). There are also a number of species of shrubs and herbs which are less characteristic of sphagnum bogs and more characteristic of a transition from forest to bog. Among these are evergreen huckleberry, salal, bracken fern, twinflower, and wild lily of the valley. Living *Sphagnum* is common.

This bog with its varied flora extends to hole 3. Between hole 3 and hole 4 the bog has been burned, but the bog shrubs are regenerating, and some fireweed has come in. The dead fire-blackened trunks of lodgepole pines are still standing. West of hole 4 the profile passes through 200 feet of a dense growth of crab apple and salal and then through 200 feet of living lodgepole pine and bracken fern.

At hole 5 the profile angles 150 feet due north to avoid a commercial cranberry bog. The vegetation at this hole includes sweet gale, salal, bracken fern, sedges, and grasses. Holes 6 and 7 are in a commercial cranberry bog. Hole 8 is in a dense growth of sweet gale 15 feet from

the commercial bog. At hole 9 the profile angles 100 feet due south, and holes 9 and 10 are in the commercial bog.

This is the only profile in the peninsula area which shows sphagnum moss of commercial quality and quantity. Good moss is present at the surface in the east 1,400 feet of this deposit, and it is 5 feet deep at hole 3 (fig. 118). The American Peat Moss Company produced moss here some years ago but did not remove a large quantity. The company's old buildings near the profile line between holes 2 and 3 are still standing. The small amount of sphagnum moss in hole 7 is too far beneath the surface to make its use practicable.

The mixture of sphagnum moss and woody peat at holes 4 and 5 might possibly be suitable for local agricultural or garden use, and the same is true of the mixture of sphagnum moss and fibrous peat at hole 8.

The fibrous peat in this deposit varies from brown to dark brown, from disintegrated to decomposed, and from wet to watery. The distribution of the woody peat and the sedimentary peat is shown in the profile (fig. 118). The deposit rests on greenish-gray sand.

Goldenberg Road profile

Goldenberg Road is also known as Parish Road and Cooper Road. It extends east and west a quarter of a mile south of the north line of secs. 21 and 22, T. 10 N., R. 11 W. The profile (4,300 feet long) extends from west to east along the north side of the road (map, fig. 118).

The vegetation at hole 1 consists of grasses and weeds, and that at hole 2, of sedges and willows. At hole 3 it consists of sedges, silver weed, and cranberry vines, and at hole 4 there is waste land on which scouring rushes and cranberry vines grow. It seems possible that the area in which holes 3 and 4 were bored is a long-abandoned commercial cranberry bog. At hole 5, shrubs (hardhack and sweet gale) and tussocks of grass are conspicuous. Salal and bracken fern also occur, and there is some living *Sphagnum*. Holes 6, 7, 8, and 9 are in commercial cranberry bogs. Cotton grass grows among the cranberry vines at all these holes, and at hole 9 there are many young spruce and lodgepole pine trees 1 to 3 feet tall. Large trees grow at hole 10. They are mostly spruce (up to 3 feet in diameter), but there are also some cedar and hemlock which are only a little smaller, and some alder. Salal, twinberry, and sedges are common. A steep timbered slope of silty clay begins 50 feet east of hole 10.

This profile (fig. 118) shows no deposit of sphagnum moss, and in general reveals shallower peat than that found in the State Highway 12A profile. It shows much sand in the first foot of depth. At hole 2 the sand is mixed with organic matter. Most of the peat in this deposit is fibrous, and it varies from brown to dark brown and from disintegrated to decomposed. Much of it is watery. The mixture of sedimentary peat and fibrous peat is dark brown. The woody peat found in hole 10 is brown. Some of the sand on which this peat deposit rests is gray, and some of it is greenish-gray.

Pioneer Road profile

The Pioneer Road profile (930 feet long) is on the south side of Pioneer Road in sec. 9, T. 10 N., R. 11 W., near the State Cranberry-Blueberry Experiment Station.



FIGURE 119.—Blueberry bushes (foreground) and cranberry marsh (background) at Washington State College Blueberry-Cranberry Experiment Station, Long Beach. Photo courtesy of Superintendent J. C. Crowley.



FIGURE 120.—New planting of cranberry vines at Cranguyma Farm. Railroad, at left, for various bog operations.

The vegetation along the profile in July 1951 consisted mostly of weeds and tussocks of a rush, but there were willows and hardhack at the east end. A ditch parallel to the profile (275 feet south, also extending northward at the east end of the profile) had recently been excavated by the use of explosives.

The peat in this profile (fig. 118) is very shallow, extending to a maximum depth of only 2 feet. It is practically all fibrous, and most of it is coarse and somewhat disintegrated. It is mixed with sand at the surface, and the

deposit rests on greenish-gray sand. One hole (hole 4, fig. 118) on the bank of the new ditch 275 feet south of the profile shows 2 feet of dark-brown coarse disintegrated fibrous peat resting on greenish-gray sand. The water in the ditch is rather weakly acidic (pH 5.0).

Gile Lake profile

The Gile Lake profile is in sec. 3, T. 10 N., R. 11 W., on Cranguyma Farm about 2 miles northeast of Long Beach. It extends southward from the south end of Gile Lake to



FIGURE 121.—Cranberry marsh at Cranguyma Farm near Long Beach. Railroad in foreground, drainage ditch at right.

Gile Road and thence westward along Gile Road (map, fig. 118) to hard land.

Hole 1 (50 feet south of the south end of the lake) is on a quaking mat of cattails, water celery, water lilies, and purple marshlocks. Hole 2 is also on the mat, which is more firm there than at hole 1, and is composed of cattails, water celery, bedstraw, and forget-me-not. Holes 3, 4, 5, and 6 are in the commercial cranberry bog.

Cranguyma Farm is said to comprise about 1,000 acres, which includes 100 acres of cranberries and 40 acres of blueberries. Rhododendrons are also grown.

This deposit (fig. 118) comprises fibrous peat, sedimentary peat, and a mixture of these. There is some peat slime in hole 6. The fibrous peat is fine in texture and is brown in all holes except hole 6, where it is dark brown. The sedimentary peat is dark brown. The deposit rests on dark-gray sand. The peat in this deposit varies from strongly acidic (pH 4.2) to weakly acidic (pH 5.5).

Joe John Road profile

The Joe John Road profile extends along the south side of Joe John Road in sec. 21, T. 12 N., R. 11 W. It is about 9 miles north of the Gile Lake profile and about 5 miles from the north edge of the area shown in figure 118.

The vegetation at hole 1 consists of scouring rush, *Juncus*, deer fern, yarrow, fireweed, and *Sphagnum*. Holes 2 and 3 are in a commercial cranberry bog. The deposit is

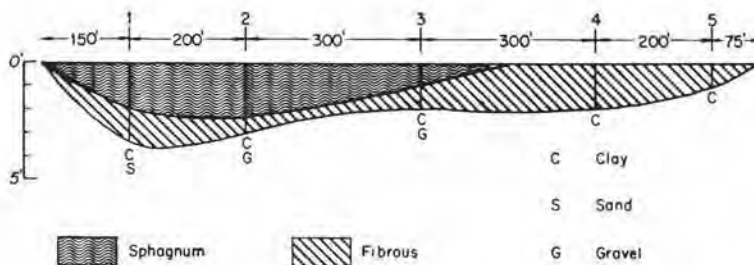

shallow, extending to a maximum depth of only 4 feet. It consists of brown fibrous peat and olive sedimentary peat. The fibrous peat is strongly acidic (pH 4.5).

Chinook peat area

The Chinook peat area (45 acres) is a sphagnum bog in secs. 30 and 31, T. 10 N., R. 10 W. It is about 3 miles east of Ilwaco and about the same distance northwest of Chinook. It is reached by driving about 1 mile north on a county road from the Chinook River bridge on U. S. Highway 101 between Ilwaco and the Astoria Ferry slip (map, fig. 122).

At the north side of the area the trunks of many dead fire-scarred lodgepole pine trees are still standing. At hole 2 there are some living lodgepole pine trees. The vegetation at hole 3 consists mainly of sedges, silver weed, and grass. At hole 4 it consists of sedge and grass, and at hole 5, sedge and various weeds. There is much living *Sphagnum* in the bog, and it forms numerous hummocks; some of it is white and has long stems. This bog evidently has been burned, perhaps more than once.

The peat is shallow, the maximum depth being 3½ feet (fig. 122). The sphagnum moss in the deposit is of good quality and reaches a depth of 2½ feet, but the area of it is small. The fibrous peat is dark brown to black. The deposit rests mostly on clay, but there is some gravel at holes 2 and 3 and some glistening sand at the bottom of hole 1.

This bog was examined by Rigg in September 1922. At that time the supply of white sphagnum was much larger than it is now. This moss is in some demand for packing and also for experimental work by botanists. It is found at only one other place (Pangborn Lake, Whatcom County) in Washington. There is some production of white sphagnum in Wisconsin.

Bay Center peat area

The Bay Center peat area is a sphagnum bog, the area of which is estimated to be 25 acres. It was visited by Rigg in September 1922 and has not been investigated since that time. It is not far from the beach, about 4 miles southeast of Bay Center.

There is a low cliff along the shore, and there are four breaks in the cliffs in the vicinity of the peat. The bog is entered by walking a short distance through a thicket in the break farthest to the south. The bog is very close to the high-tide level, but no salt-marsh vegetation was seen

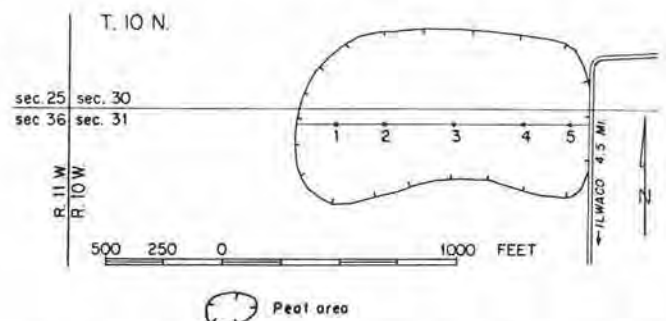

FIGURE 122.—Map and profile of Chinook peat area (45 acres). Map adapted from U. S. Army Map Service photomosaic.

in it. The bog has the usual flora of shrubs and herbs, and there are some cedar, spruce, and cascara trees in it.

Fibrous peat and peat slime were found by boring, and blue clay with some sand was found at 15 to 19 feet.

Grayland peat area

The Grayland peat area (1,946 acres) is in sec. 31, T. 16 N., R. 11 W.; secs. 6, 7, 8, 17, 18, 20, 29, and 32, T. 15 N., R. 11 W.; and secs. 4 and 5, T. 14 N., R. 11 W. Although the northern part of it (479 acres) is in Grays Harbor County, the area is all described here under Pacific County. It is about 7 miles long, and its maximum width is a little over $\frac{1}{2}$ mile. It extends from North Cove, which is a part of Willapa Harbor, to within 2 miles of South Bay, which is a part of Grays Harbor (map, fig. 123). The area lies just behind the line of ocean dunes and, except at the southern end, is mostly about $\frac{1}{2}$ mile from the shore of the Pacific Ocean. On the east side it is bordered by low hills. There are some lakes and ponds on the peat area or its borders, and several creeks flow across it.

On this peat area are many commercial cranberry bogs; their total area is estimated at 500 acres. Several different plant communities occur on the unimproved parts of the peat. Some of these are on very shallow peat, and some probably extend onto the bordering hard land. There are wild cranberry bogs, swampy areas, sedge areas, brushy areas, patches of coniferous forest, and transition zones between these areas.

Living *Sphagnum* is abundant in the sphagnum bogs, and representative shrubs are Labrador tea, bog laurel, and the small woody vines of the native cranberry. Among the common herbaceous species are cotton grass, sundew, herbaceous dogwood, and a small white orchid. Patches of crowberry (a low woody vine resembling heather) are abundant in the vicinity of Heather Road.

In the swampy places skunk cabbage, buckbean, purple marshlocks, water celery and swamp ferns are common. The open sedge areas are covered with various sedges, reeds, and grasses.

In some brushy areas of considerable size there is a dense growth of hardhack and sweet gale which in some places reaches a height of 10 feet. Other common shrubs are huckleberry, salal, and fool's huckleberry. The trees in the coniferous forest are mostly lodgepole pine, spruce, and cedar; many of them are stunted, and large trees are rare.

Other common species occurring in the transition zones or mixed with other species in the several areas mentioned above are twinflower, star flower, wild lily of the valley, deer fern, scouring rush, bedstraw, fireweed, bracken fern, and mosses other than *Sphagnum*. One shrub not mentioned in any of the lists deserves special mention. It is the wax myrtle, an attractive evergreen shrub which sometimes approaches tree size, belonging to the same genus as the sweet gale. Two species of Labrador tea also occur. One of them has, on the under surface of its leaves, a dense growth of rust-colored hairs, and the other does not have hairs on the under surface of its leaves but has a powdery white waxy coating instead.

The 2,200-foot profile extending from west to east across the peat is shown on the map (fig. 123). The two jogs in

it were made to avoid trampling the vines in commercial cranberry bogs. This is a shallow profile, the maximum depth being 7 feet.

The sphagnum is brown and of good quality near the surface, but farther down it is dark brown and disintegrated. At the bottom of the layer it is decomposed and watery. The fibrous peat is brown to dark brown, and mostly disintegrated to decomposed. Some of it is watery. Most of it consists of the remains of ordinary sedges, but some is coarse and some is fine and felty. There is some sand mixed with the fibrous peat in the lower 6 inches. The deposit rests on sand.

One hole 100 feet west of Redding Road and 200 feet south of Lindgren Road near the center of sec. 20, T. 15 N., R. 11 W., shows 2 feet of sphagnum and 3 feet of fibrous peat with sand under it. The sphagnum in the first foot is good, but in the second foot it is disintegrated. The fibrous peat is brown and watery and contains some wood near the top.

Two holes were bored in the Grayland peat area by Rigg in 1921, but their location was not accurately determined. One was 5 feet deep and the other 6 feet. Sand was found at the bottom of both.

PEND OREILLE COUNTY DEPOSITS

The 18 peat areas investigated in Pend Oreille County comprise three geographical groups.

The southern group consists of nine peat areas and includes all but one (Big Meadow) of the larger peat areas of the county. The group lies west and south of the Pend Oreille River, in a lowland area of about 200 square miles. The area is covered by glacial till and glaciofluvial sand, gravel, and silt, through which project low hills of granite and metasedimentary rocks. Several of the peat areas here are on constructional terraces of the river at elevations close to either 2,150 or 2,350 feet above sea level, but one (Kent Meadows) is in the valley of a tributary stream at an elevation of 2,550 feet, slightly more than that of the others. The group is compact, the distance from the southernmost to the northernmost peat area being only 12 miles. The drainage of the region in which these peat areas occur is mostly to the Pend Oreille River, but some of it goes to the Little Spokane River.

The north-central group consists of 7 areas, all within 11 airline miles of the village of Tiger, which is about 4 miles south of Ione. All but one (Big Meadow) of the included peat areas are within the drainage basin of the Pend Oreille River. Big Meadow is on the divide between this drainage basin and that of the Colville River. All the areas except Bunchgrass Meadow are west of the Pend Oreille River. The elevation of the peat areas of the north-central group varies from 3,450 feet (Big Meadow) to 5,000 feet (Bunchgrass Meadow).

The northern group, consisting of only two areas, is north of Metaline Falls and close to the Canadian border. It is west of the Pend Oreille River, on a terrace at an elevation of 2,550 feet.

At Newport (elevation 2,135 feet), which is near the southern group of peat areas, the average length of the growing season for the 22 years preceding 1941 was 93

days, and the average annual precipitation for the same period was 22.59 inches. At Sullivan Lake, which is near the north-central group, the length of the growing season for the 13 years preceding 1941 was 114 days, and the average annual precipitation for the 18 years preceding 1941 was 26.19 inches.

SOUTHERN GROUP

Southwest End Diamond Lake peat area

The peat area (528 acres) bordering the southwest end of Diamond Lake is in secs. 3, 8, 9, 10, 16, and 17, T. 30 N., R. 44 E., about 9 miles west of Newport. U. S. Highway 195 (Spokane to Newport) passes close to its southern border (map, fig. 124). The area is elongated and is very irregular in shape. Moon Creek flows out of the lake and across the peat. There are rock outcrops near the peat, and an "island" of hard land borders the lake.

The part of the area in the vicinity of the profile is a sedge meadow covered by 1 foot of standing water. There are some peat-bog birches of shrub size along the creek which drains the lake, and in some places there are rushes and aquatic plants. The elevation of Diamond Lake is 2,350 feet above sea level.

The profile (fig. 124) shows mostly fibrous peat. It is light brown to dark brown and varies from raw to disintegrated. Some of it near the top of the layer is watery. The black muck at the surface is weakly acidic (pH 5.0). The mixture of fibrous peat and sedimentary peat in hole 1 is olive colored. The pumicite is light brown to brown. The layer is 7 inches thick at hole 1 and 14 inches thick at hole 3, but only 1 inch thick at hole 2. This distribution suggests that part of it lying near the borders was washed in from the surrounding slopes. The deposit rests on sand and gravel, with some clay at hole 3.

Northeast End Diamond Lake peat area

The irregular peat area (341 acres) which extends northeastward from near the northeast end of Diamond Lake is in secs. 30 and 31, T. 31 N., R. 45 E., and secs. 25

and 36, T. 31 N., R. 44 E. (map, fig. 125). U. S. Highway 195 (Spokane to Newport) passes near the peat, and county roads give access to the various parts of the area. There are four "islands" of hard land in this peat area. It is possible that the peat extends to the lake, but the building of houses and the construction of the road have disturbed the surface. The Little Spokane River flows across this peat area.

The land in the vicinity of profile A is utilized for the production of oats and hay. The profile is in a hayfield and is just north of a drainage ditch. The profile (fig. 125) shows fibrous peat with a layer of muck over it. The fibrous peat is brown to dark brown, and some of it is raw. It is weakly acidic (pH 5.5). The muck is dark brown to black and is also weakly acidic (pH 5.0). The layer of pumicite (12 inches thick at hole 1) is tan colored at the top and white at the bottom.

Profile B is in a sedge meadow which is used as pasture for stock. The muck is black, and the fibrous peat is dark brown. The pumicite is tan colored. The deposit rests on sand and clay.

Profile C is at the extreme south end of the area, where the vegetation consists of lodgepole pine, peat-bog birch, hardhack, sedges, swamp ferns, and grasses. The fibrous peat is brown to dark brown to black, and is disintegrated to decomposed. It is weakly acidic (pH 5.0 to 5.5). Marsh gas (methane) escapes in bubbles as holes are bored. The pumicite is brown and forms a layer 1 foot thick. The deposit rests on gray sand, which is watery at hole 2.

Sedge Meadow near Diamond Lake

The sedge meadow (area about 20 acres, 2 miles southwest of Diamond Lake, is near the center of sec. 15, T. 30 N., R. 44 E. It contains no peat, though its appearance is similar to that of other areas in Pend Oreille County which do contain peat. A ditch, through which water flows before spreading out on a flat, crosses the area. There is a hayfield nearby.

A hole bored 20 feet north of the ditch shows 16 inches of black muck, under which is 16 inches of brown pumi-

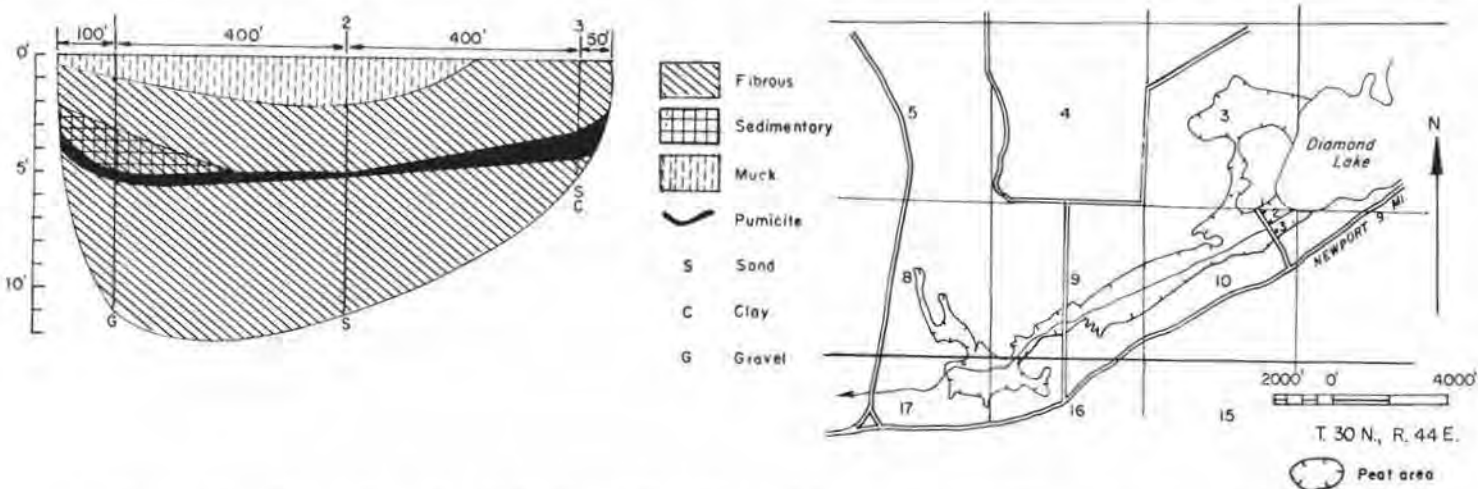

FIGURE 124.—Map and profile of Southwest End Diamond Lake peat area (528 acres). Map adapted from U. S. Soil Conservation Service soil map and aerial photograph.

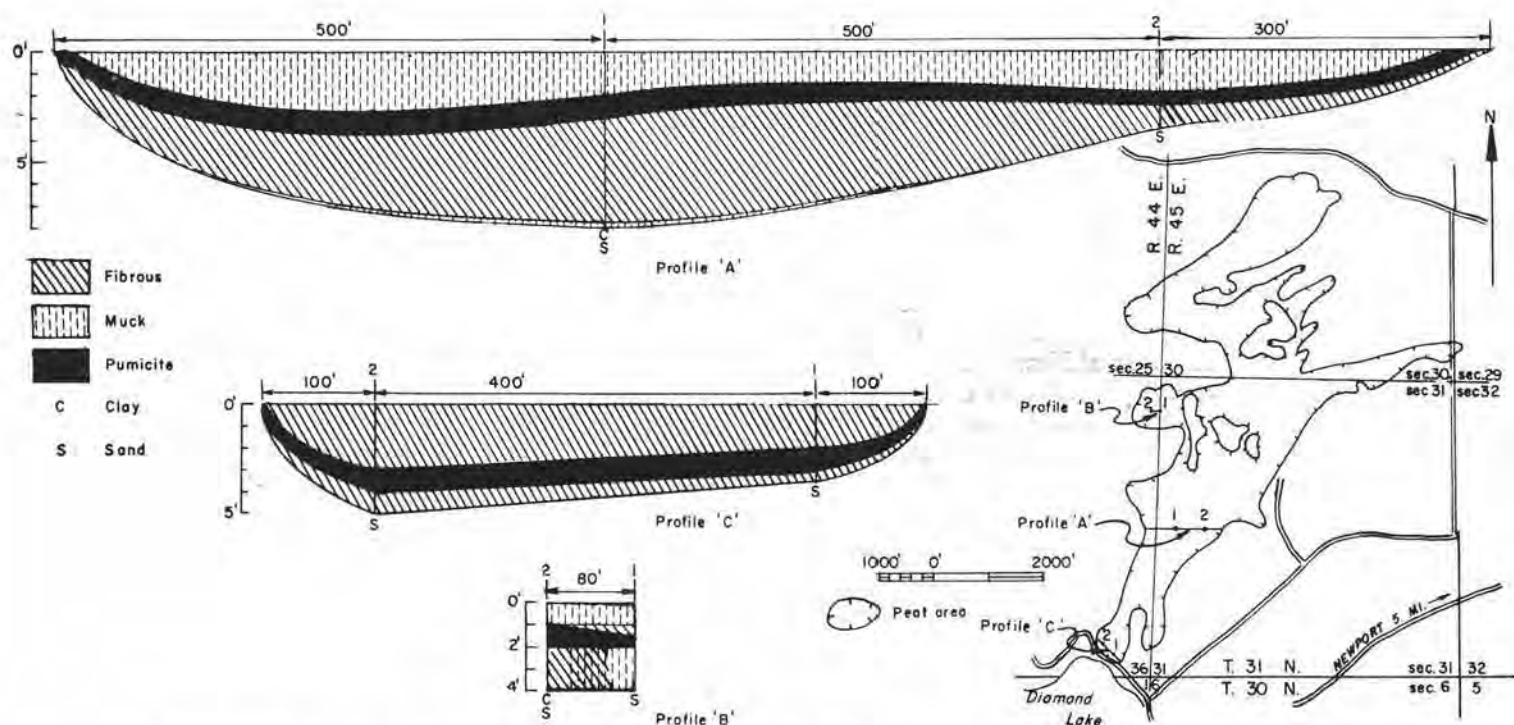

FIGURE 125.—Map and profiles of Northeast End Diamond Lake peat area (341 acres). Map adapted from U. S. Soil Conservation Service soil map and aerial photograph.



FIGURE 126.—Making a boring in Davis Lake peat deposit, Pend Oreille County. Photo by M. T. Hunting.

cite. Under this is a gray mixture of sand and clay. The muck is rather weakly acidic (pH 5.0). The pumicite (pH 5.3) is slightly less acidic than the muck.

Northeast Shore Davis Lake peat area

The peat area (97 acres) bordering the northeast shore of Davis Lake is in secs. 29, 31, and 32, T. 32 N., R. 44 E., about 14 miles northwest of Newport. An improved road crosses the peat (map, fig. 127). Davis Creek flows northward across the peat from Davis Lake to the Pend Oreille River.

Only one hole was bored in this area (see map). It is in a hayfield close to the road and also close to a drainage ditch.

The materials found in this hole (fig. 127) are fibrous peat, sedimentary peat, muck, diatomite, marl, and pumicite. The fibrous peat is brown to dark brown and is disintegrated. The mixture of fibrous and sedimentary peat is also brown to dark brown. It contains many seeds, probably of buckbean. The muck is black except where its mixture with diatomite gives it a lighter color. The marl is gray, and the 1-foot layer of pumicite is tan at the top and almost white at the bottom. The clay under the marl is blue.

South End Davis Lake peat area

The peat area (67 acres) bordering the south end of Davis Lake (map, fig. 128) is in secs. 6 and 7, T. 31 N., R. 44 E., about 15 miles northwest of Newport. State Highway 6B passes near the eastern border of the peat and crosses an eastern extension of it. Deer Creek flows northward through the entire length of the peat area and into the lake. As the peat is more than 30 feet deep under the creek, it is evident that the creek found its present channel after the peat was formed. There are rocky hills on both sides of the area, and a rocky outcrop borders the lake and extends into the peat area. The elevation of the lake is 2,150 feet above sea level.

Holes 1 and 2 of the profile are in a sedge meadow in which the sedges are 3 feet tall and form a dense growth. At hole 3 the sedges are in standing water, and some aquatic plants grow among them. At hole 4 the vegetation consists of sedges, swamp ferns, and mint.

This is the deepest peat deposit known in Pend Oreille County (fig. 128). At hole 3 the peat is 36½ feet deep

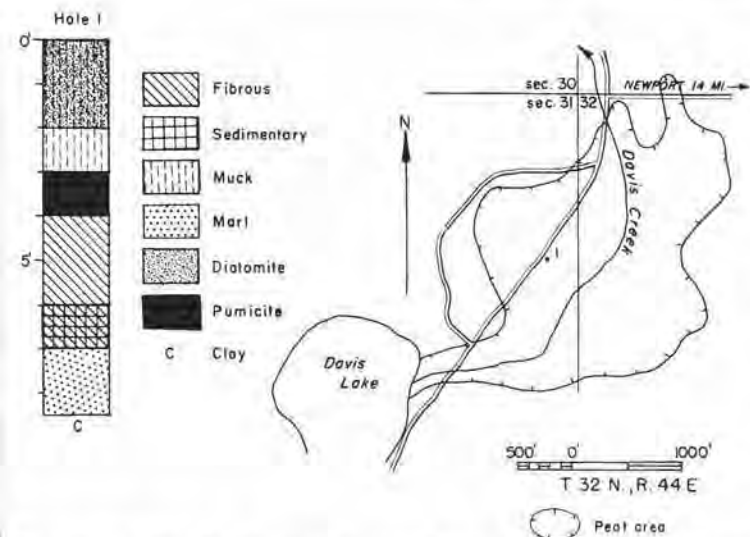

FIGURE 127.—Map and graphic log of a hole in Northeast Shore Davis Lake peat area (97 acres). Map adapted from U. S. Soil Conservation Service soil map.

There is soft blue clay at the bottom of hole 1, and light-gray alkaline clay (pH 7.8) at the bottom of hole 2. At holes 3 and 4 bottom was not reached because the pumicite is too compact to be penetrated with the beat borer.

Kent Meadows peat area

The Kent Meadows peat area (175 acres) is in secs. 10 and 15, T. 31 N., R. 44 E. (map, fig. 129), about 13 miles by indirect road east of Newport. There is some drainage by a ditch from the peat area to Kent Creek, which flows north to the Pend Oreille River, but the ditch is not deep enough to drain the lower parts of the area. The elevation of this peat is 2,550 feet above sea level.

Some of the area is covered with water. At hole 3 the water is 2 feet deep, and at hole 4 it is 1 foot deep. Between these two holes (estimated distance 1,800 feet) the water is too deep to wade. At hole 3 the vegetation consists of sedges, tules, and aquatic plants; at hole 4 it consists of rushes and aquatic plants. In the vicinity of hole 5 some peat-bog birches are growing, and there is evidence of the destruction of some larger trees (probably conifers) by burning long ago. Holes 1 and 2 are in a pasture, and holes 5 and 6 are in a hayfield.

The material present in largest amount in the profile (fig. 129) is olive to olive-green sedimentary peat. Next in amount and forming most of the surface is fibrous peat, which is light brown to dark brown and raw to disintegrated. The amount of marl in this profile is relatively large. It is tan to light gray where it is pure, and darker colored where mixed with other materials. The muck is black. The pumicite is mostly white but is light gray in some places. It forms a layer 4 to 12 inches thick. The peat and muck are weakly acidic (pH 5.8 to 6.7). The pumicite in hole 1 is neutral (pH 7.0). The deposit rests on soft clay which is blue except at hole 2, where it is dark gray.

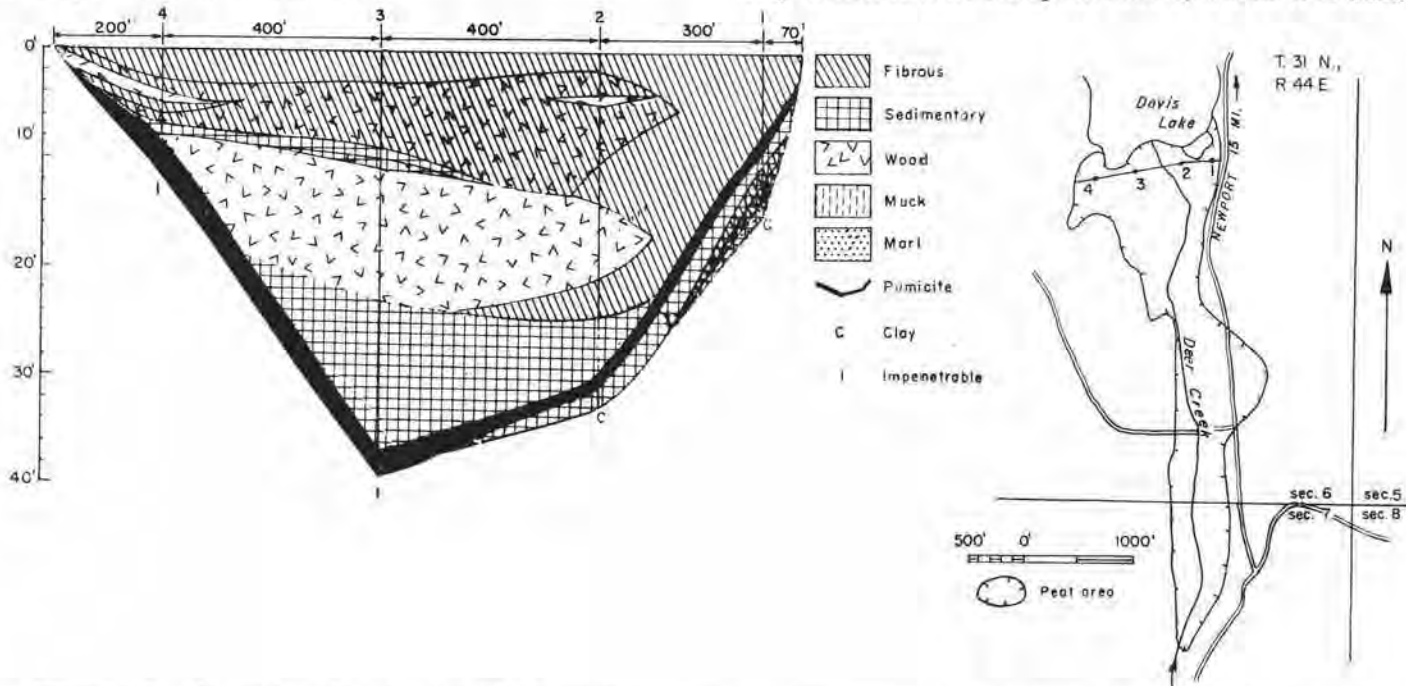

FIGURE 128.—Map and profile of South End Davis Lake peat area (67 acres). Map adapted from aerial photograph.

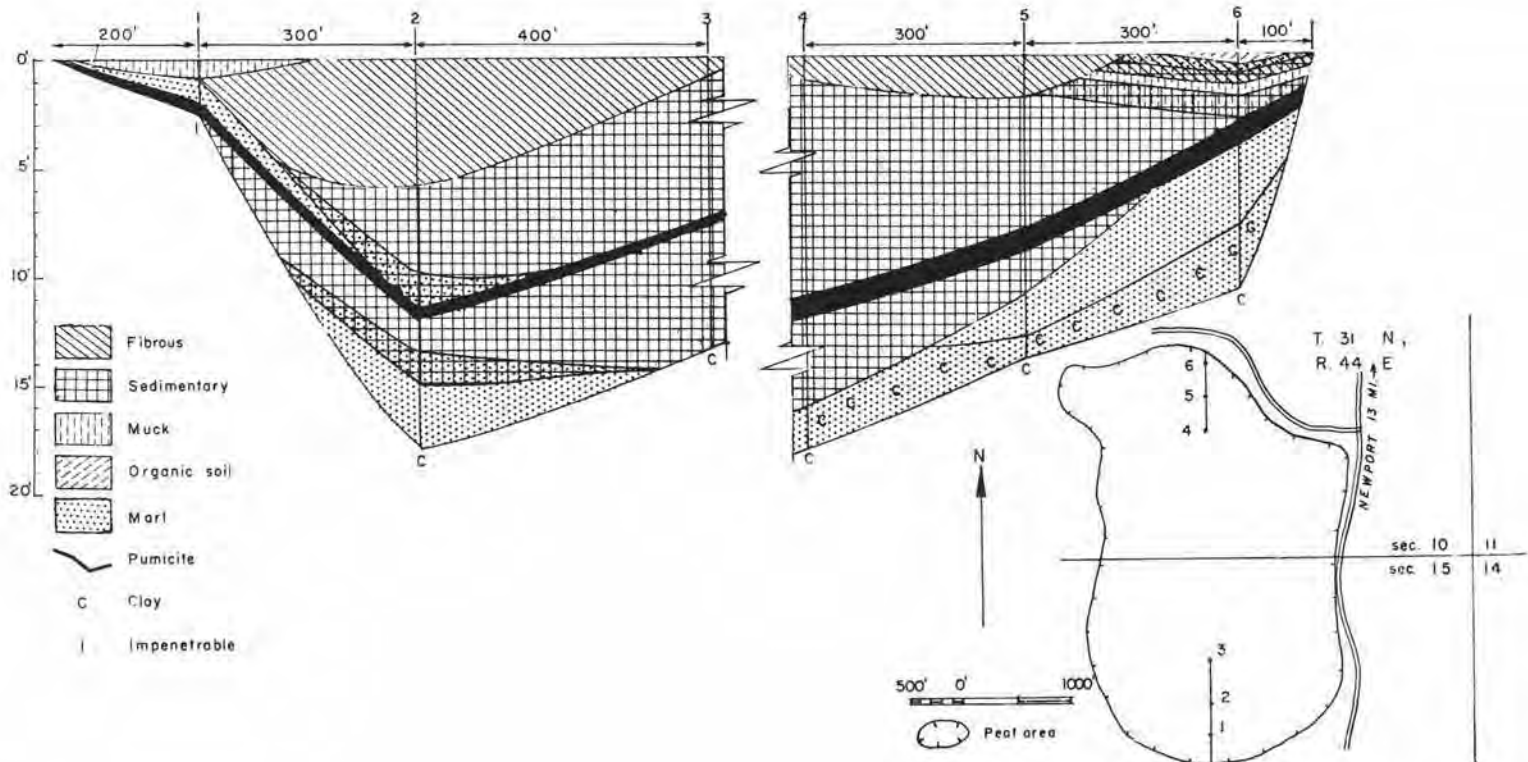

FIGURE 129.—Map and profile of Kent Meadows peat area (175 acres). Map adapted from U. S. Soil Conservation Service soil map.



FIGURE 130.—Making a boring in a hayfield on Kent Meadows peat deposit.

Deer Creek peat area No. 1

Deer Creek peat area No. 1 (200 acres) is in secs. 7, 18, and 19, T. 31 N., R. 44 E., about 12 airline miles west of Newport. Deer Creek flows northward across it (map, fig. 131). A road extending to Newport crosses the northern part of the area, and a branch of this road crosses the southern part. The elevation of this peat area is 2,150 feet above sea level.

The only hole bored in this area is in a hayfield near the north quarter corner of sec. 19. The materials present (fig. 131) are muck, diatomite, fibrous peat, and pumicite. The fibrous peat is brown and decomposed. It rests on gravel, and all the other materials lie above it. The muck

is dark brown to black, and its acidity (pH 4.8) is close to the borderline between weak and strong. The diatomite is tan, and the pumicite is brown and forms a layer 15 inches thick.

Deer Creek peat area No. 2

Deer Creek peat area No. 2 (195 acres) is in secs. 10, 11, 13, and 14, T. 31 N., R. 43 E., about 12 airline miles west of Newport. It is just southeast of Rocky Gorge. It lies along Deer Creek (map, fig. 132), which also flows across two other peat areas (Deer Creek Number 1, and the area at

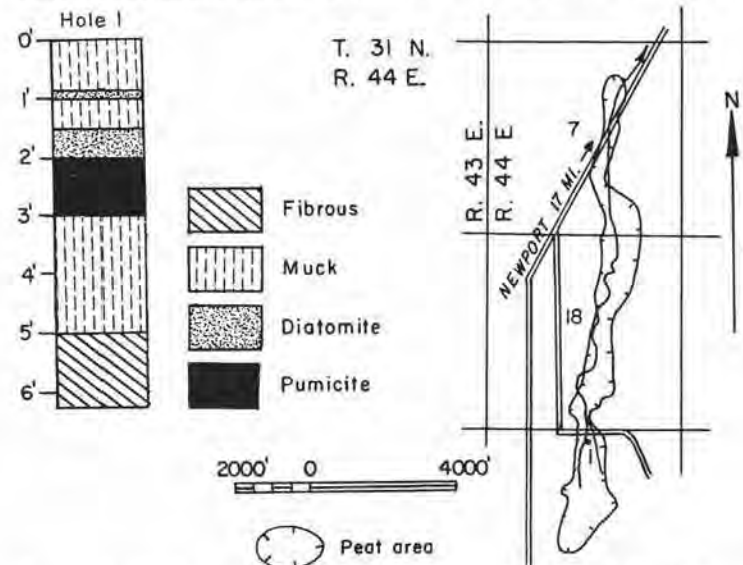

FIGURE 131.—Map and graphic log of a hole in Deer Creek peat area No. 1, Pend Oreille County (200 acres). Map adapted from aerial photograph.

the south end of Davis Lake) before reaching Davis Lake. The movement of the water in this creek and the drainage ditch is slow.

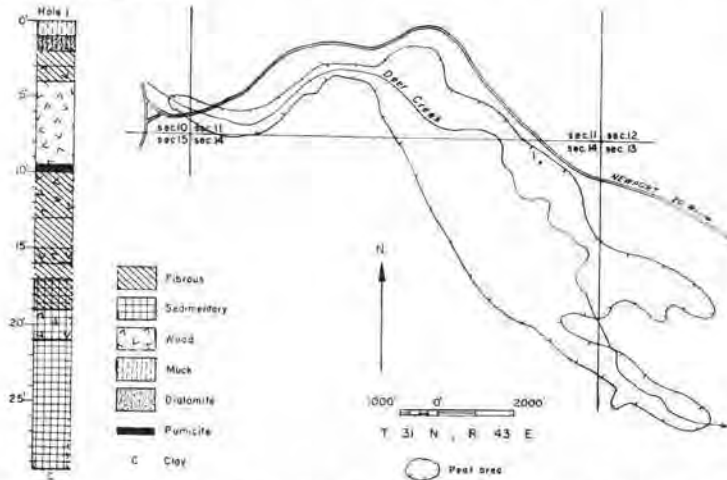

FIGURE 132.—Map and graphic log of a hole in Deer Creek peat area No. 2, Pend Oreille County (195 acres). Map adapted from U. S. Soil Conservation Service soil map.

The one hole bored in this peat is in a large hayfield. The hole is 29 1/2 feet deep (fig. 132), and the materials found in it are fibrous peat, muck, woody peat, sedimentary peat, pumicite, and mixtures of these. The fibrous peat is light brown to brown and is disintegrated. The muck is black. The woody peat is brown; all of it is wet, and some of it is even watery. The sedimentary peat is olive green to dark green. The pumicite (6 inches thick) is tan colored. The deposit rests on light-gray soft clay.

The peat and the water in the ditch are weakly acidic (ditch, pH 5.8; muck, 5.4; fibrous peat, 6.0).

Rocky Gorge Meadow

Rocky Gorge Meadow (about 20 acres of muck) is in sec. 10, T. 31 N., R. 43 E., less than 1 mile northwest of Deer Creek peat area No. 2. Low rock hills border it.

No peat was found in this area. It was investigated because it is shown as a lake on the Newport quadrangle, U. S. Geological Survey. The lake has probably been drained. It is now a meadow of reed canary grass. The soil gives firm footing and is not wet.

One hole in the center of the area shows 1 foot of brown soil, 2 feet of a brown mixture of diatomite and soil, and 1 foot of gray diatomite. The diatomite at the 4-foot depth is too compact to be penetrated farther with the peat borer.

NORTH CENTRAL GROUP

Big Meadow peat area

The Big Meadow peat area (approximately 170 acres) is in secs. 6 and 7, T. 37 N., R. 42 E., about 7 miles by road west of Ione. Its elevation is 3,450 feet above sea level, and it lies on the divide between the Pend Oreille River drainage and the Colville River drainage. Big Meadow Lake is near the center of the area, and its outlet, Meadow Creek, flows into a fork of Deep Creek, whose waters eventually reach the Columbia River.

This area is mostly a sedge meadow. Along the profile (map, fig. 133) the vegetation consists of a sparse growth of low sedges and grasses, with some aquatic plants at hole 3, which is near the lake. There is a drainage ditch near hole 4.

The materials found in the profile are fibrous peat, sedimentary peat, wood peat, muck, marl, diatomite, and pumicite. There are also mixtures of some of these, the quantity of mixed fibrous and sedimentary peat being especially large. The deposit rests mostly on soft clay which is gray to gray blue in color, but there is some sand at the margins.

The fibrous peat is brown to dark brown and raw to disintegrated. The sedimentary peat is olive green, and the wood peat is brown. The muck is gray brown to black, and the marl is gray to tan. The diatomite is tan colored and is present in hole 1 only, and there in small quantity. There are two layers of pumicite. The upper layer is light gray to tan and is all within 8 feet of the surface. It is thick (as much as 6 inches) at the margins of the area and thin in the middle. The lower layer, coarse and white, is thin (1/2 inch) and is entirely in the marl.

Abandoned equipment on this peat area indicates that hay has been produced there in recent years.

Bunchgrass Meadow peat area

The Bunchgrass Meadow peat area (69 acres) is in sec. 24, T. 37 N., R. 44 E., about 15 miles southeast of Ione by

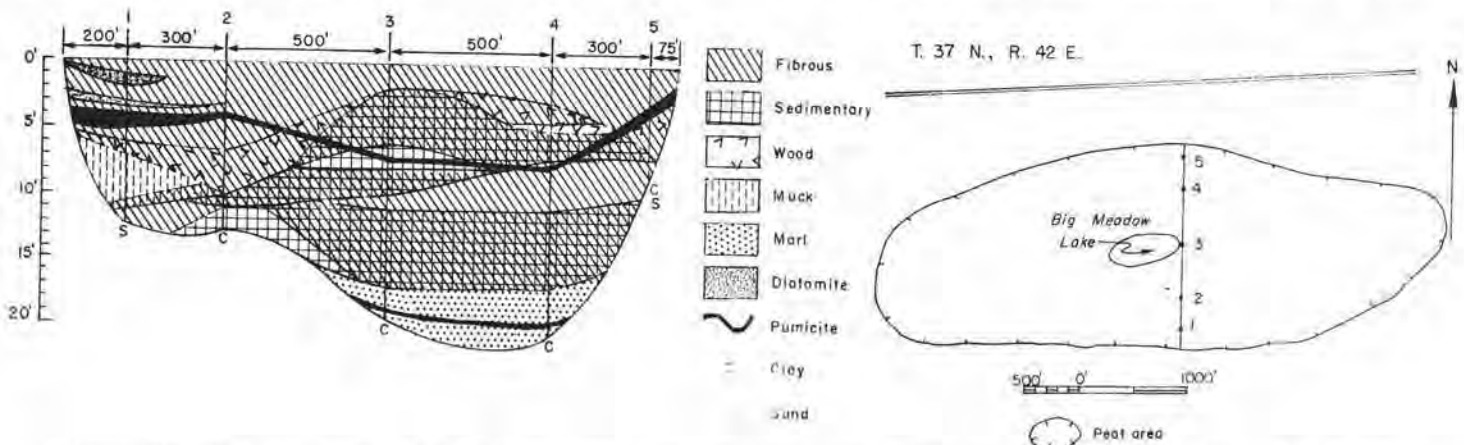

FIGURE 133.—Map and profile of Big Meadow peat area (approximately 170 acres). Map adapted from field sketch.

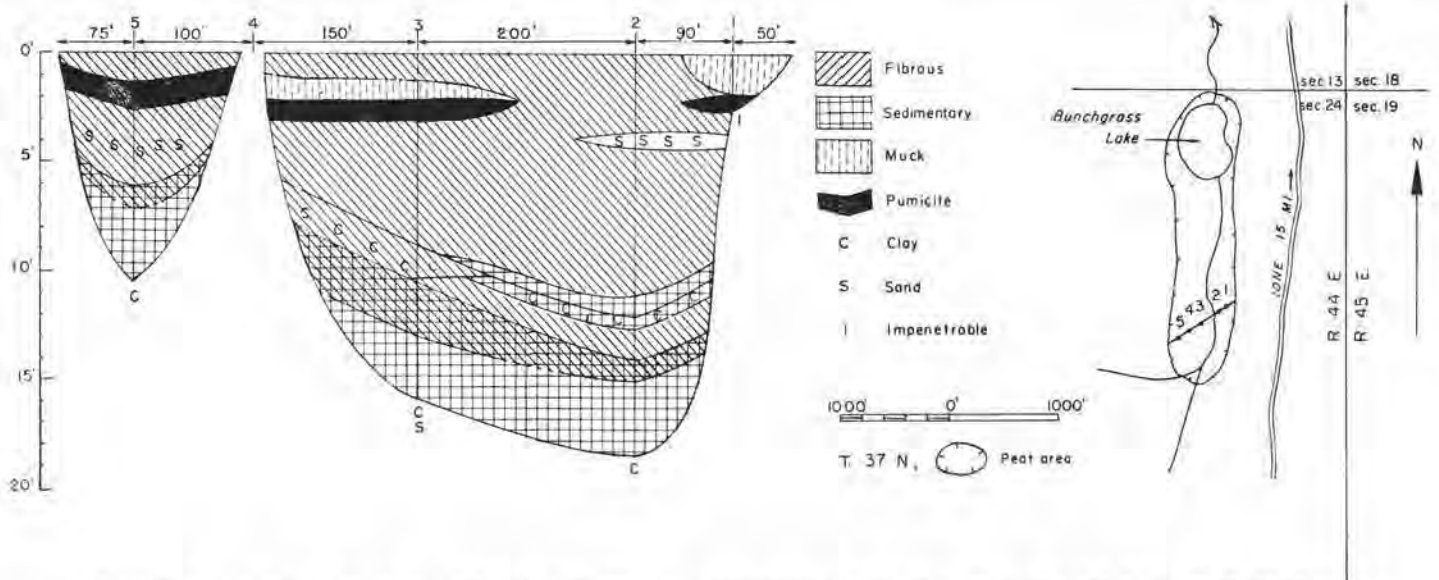

FIGURE 134.—Map and profile of Bunchgrass Meadow peat area (69 acres). Map adapted from U. S. Geological Survey topographic map (Metaline quadrangle).

way of a road which passes near it (map, fig. 134). The water of the stream which flows across the peat and through Bunchgrass Lake eventually reaches the Pend Oreille River. The elevation of the peat is 5,000 feet above sea level, the highest elevation of the peat bogs investigated in the state. The area is about 1 mile north of Monumental Mountain. This is the only known peat area east of the Pend Oreille River in Pend Oreille County.

The plants growing in the vicinity of the profile are mostly sedges with some grasses, but near the east border in the vicinity of hole 1 there is a small sphagnum bog. *Sphagnum* grows along a small stream which originates from seepage from the higher land nearby. The plants growing with the *Sphagnum* are a sedge, bog laurel, and a violet. Peat-bog birch, a scouring rush, and lousewort grow nearby. There is an abandoned house on hard land near hole 5.

The materials in this deposit (fig. 134) are fibrous peat, sedimentary peat, muck, pumicite, and some sand and

clay. There is a ridge of hard land at hole 4. The fibrous peat is brown and some of it is raw. The sedimentary peat is olive to olive green. The pumicite is brown, and in hole 1 it is too compact to be penetrated with the peat borer below the 2½-foot level. In the other holes it varies from 6 to 12 inches in thickness. The materials vary from weakly acidic (pH 5.3) to strongly acidic (pH 4.5).

Rufus Meadow peat area

The Rufus Meadow peat area (30 acres) is in secs. 26 and 27, T. 36 N., R. 42 E., about 12 miles by road southwest of Tiger. Its elevation is 4,150 feet above sea level. Some drainage from it goes to the South Fork of Lost Creek, which flows into the Pend Oreille River. The area is long and narrow (map, fig. 135).

The vegetation of this peat area is quite varied. East of hole 1 of the profile there is a willow thicket with *Sphagnum*, sedges, and grasses growing in its border. In the vicinity of hole 1 the vegetation consists of willow,

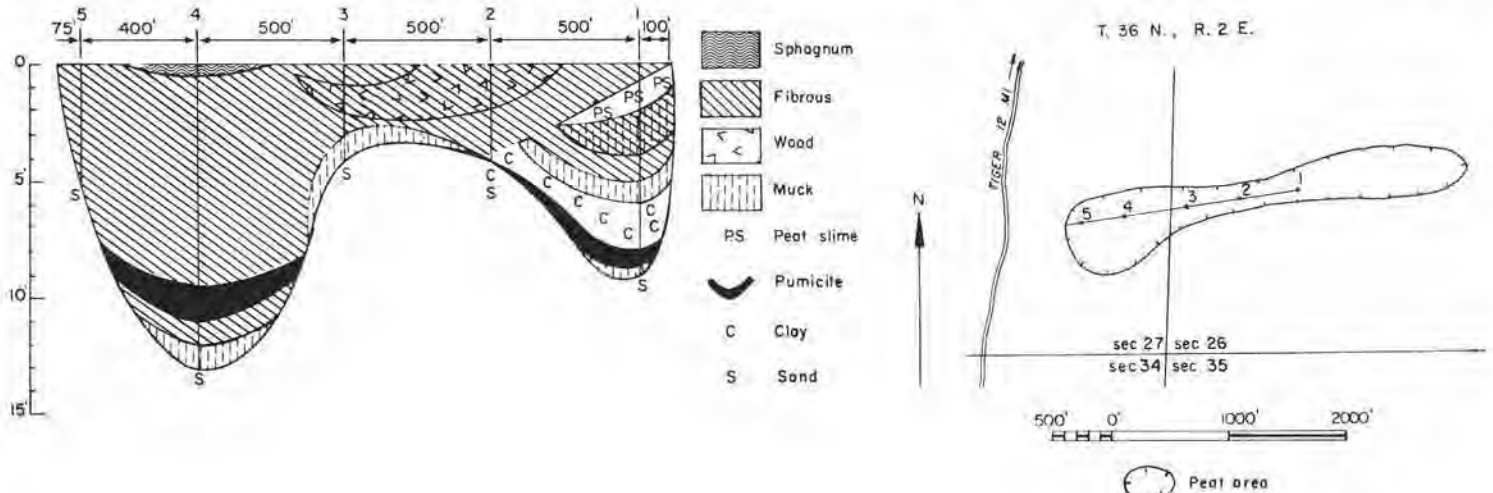

FIGURE 135.—Map and profile of Rufus Meadow peat area (30 acres). Map adapted from U. S. Geological Survey topographic map (Metaline quadrangle).

alder, peat-bog birch, and sedge. Near hole 2 there are mostly sedges, and at hole 3 there are sedges and grasses. In the vicinity of hole 4 there is a sphagnum bog in which very few shrubs are present, and the vegetation consists of living *Sphagnum* and several species of herbaceous bog plants. The *Sphagnum* forms a continuous cover and also forms hummocks in which herbaceous bog plants grow. In the vicinity of hole 5, sedges, lousewort, and peat-bog birch grow with the *Sphagnum*.

The deposit consists mostly of fibrous peat (fig. 135). The amount of wood peat, peat slime, and muck is relatively small. The fibrous peat is brown to dark brown and disintegrated to decomposed. The muck is brown to black, and the pumicite is tan to brown. It is 11 to 18 inches thick. The deposit rests mostly on sand, but there is some clay at the bottom of hole 2. An unusual feature of this deposit is the presence of 2 feet of clay over the pumicite in hole 1. The fibrous peat at the depth of 1 foot is rather strongly acidic (pH 4.5).

There is hard land 100 feet east of hole 1. No digging or boring was done east of this point. No evidence of any attempt at utilization was seen.

Lost Creek peat area

The Lost Creek peat area (5 acres) is in secs. 28 and 29, T. 37 N., R. 42 E., about 5 airline miles west of Tiger. An unimproved forest road passes near the peat (map, fig. 136), and the deposit is easily reached from either Ione or Tiger. Lost Creek flows near the peat. Beavers have dammed the creek between the road and the peat.

This is a raised bog. Along the line of the profile the surface rises about 8 feet in a distance of 350 feet. Along the remainder of the profile the surface of the peat is flat and approximately level. The bog thus does not have either a dome shape or a ridge shape, but is built against an elevation of hard land. This form is much less common than the dome or ridge form, but it may be called a raised sphagnum bog because it is raised at one side and has the typical convex surface, also it has living *Sphagnum* at the surface, and it contains some sphagnum peat. Inspection

of the profile (fig. 136), however, reveals clearly that *Sphagnum* has not been the principal factor in causing this bog to have a raised form. At hole 6, where the elevation of the surface is 5½ feet higher than at hole 7, there is no pure sphagnum peat and only 1 foot of mixed sphagnum and fibrous peat. Evidently, sedges and similar plants have been the principal factor in giving this bog its raised form. In this, it is similar to Pillar Bay bog in Kuiu Island in Alaska (Rigg, 1937) and Iron Spring bog in northern Minnesota (Rigg, 1940). Examples of typical raised sphagnum bogs with a dome or ridge form in whose development *Sphagnum* has been the principal factor are seen at Juneau, Alaska (Rigg, 1937) and at Harrington, Maine (Rigg, 1940).

The fibrous peat in the Lost Creek bog is brown to reddish brown to dark brown to black. Much of it is decomposed, and some of it is watery. The sphagnum peat is brown. The living *Sphagnum* is strongly acidic (pH 4.3). The muck is black and watery. The pumicite is yellow to brown, and some of it is watery. It is 2 to 9 inches thick. The deposit rests on sand, fine gravel, and clay.

Coniferous forest borders most of the bog. There is also coniferous forest on the western part of the bog in the vicinity of holes 1 and 2, and there small deciduous trees grow with the conifers; and twinflower, herbaceous dogwood, and scouring rush form a sparse ground cover. The eastern part of the bog in the vicinity of holes 4, 5, 6, and 7 is mostly treeless, and the plant community there is composed mostly of typical bog herbs, especially those characteristic of wet sphagnum bogs. Sundew, cotton grass, buckbean, and purple marshlock are common. One low bog shrub (a huckleberry) also occurs.

Data on this bog, including the log of a boring, are recorded in field notes dated May 21, 1935, by the late A. P. Dachnowski-Stokes; these, so far as known, were never published. The log of his boring shows essentially the same data as those reported above. He records that the coarse woody material found in his boring consists of beaver chips. He records that this is a "raised sphagnum bog with center more than 5 feet above the margin of the

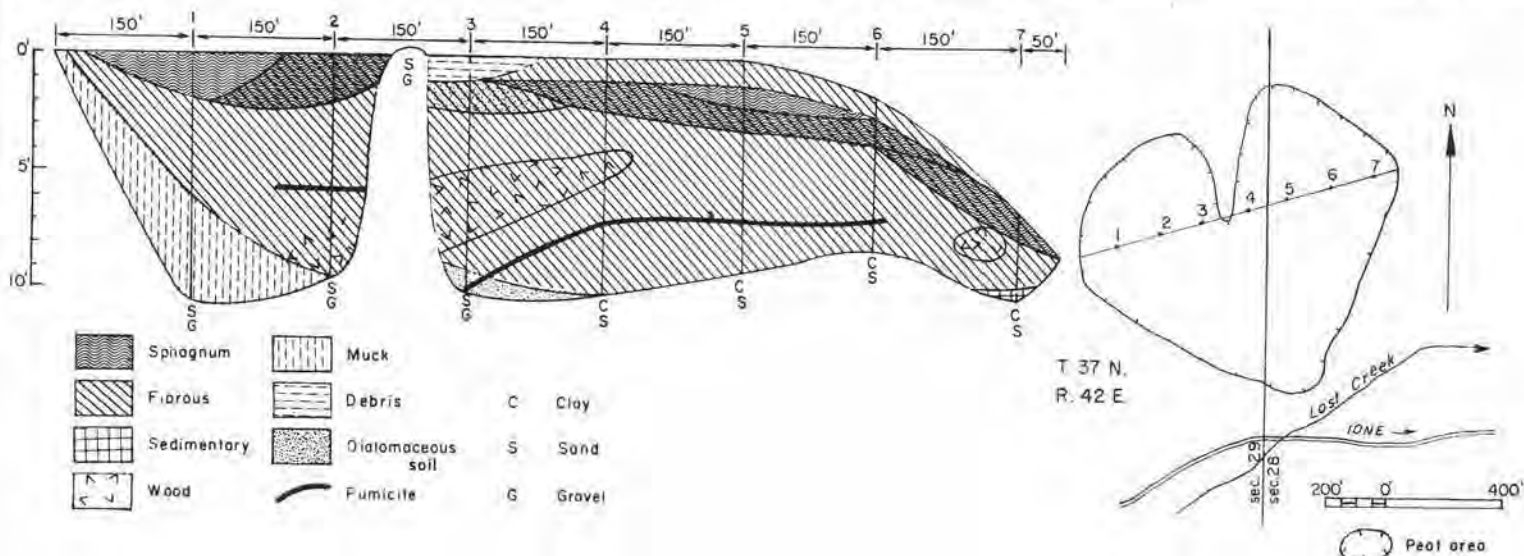

FIGURE 136.—Map and profile of Lost Creek peat area (5 acres). Map adapted from field sketch.

area" and states that it "resembles the muskegs of Minnesota." He found that the pH at the surface was "4.0 or less" and at the depth of 7 inches it was 4.5, and that the pH of the fibrous peat at the depth of 2½ to 3½ feet was 6.0.

Granite Mountain peat area

The Granite Mountain peat area (4 acres, estimated) is in sec. 14, T. 36 N., R. 42 E. It is about 6 airline miles southwest of Tiger, but the distance by road is considerably more. The road which leads to the Granite Mountain Lookout crosses the west end of the peat. The elevation of the peat is about 4,350 feet above sea level.

This is a sedge meadow on which there is some standing water. Some grasses and *Geum* grow among the sedges. The land bordering the west side of the peat is flat, and its elevation is only slightly greater than that of the surface of the peat. On this flat is a dense growth of lodgepole pine extending to the border of the meadow. The only transition from the one to the other consists of a few small peat-bog birch trees. On the north, south, and east sides the meadow is bordered mostly by higher land on which the forest has been logged.

The upper 1 foot of this deposit is brown fibrous peat. Under this is a 26-inch layer of brown fibrous muck, which is weakly acidic (pH 5.3). Under this is a 10-inch layer of light-gray pumicite, which rests on light-gray sand.

Ruby Creek Meadow

Ruby Creek Meadow (1 acre, estimated) is in sec. 3, T. 35 N., R. 42 E., about 9 airline miles northwest of Ruby and about 12 airline miles southwest of Ione. It is conveniently reached by road from either of these towns. Ruby Creek flows near the meadow and into the Pend Oreille River. A tributary of Ruby Creek flows through the meadow. The elevation of the meadow is about 3,750 feet above sea level.

This is a wet sedge meadow with *Sphagnum* growing in shallow depressions and also on hummocks around small spruce trees. The deposit is shallow (2½ feet) and contains no peat. It is described because of the *Sphagnum* which grows in it and which is rare in eastern Washington, occurring there in Pend Oreille County only, so far as known. The deposit consists of muck which is rather strongly acidic (pH 4.7) and is mixed with sand in some places. It rests on sand and clay, and there is some wood mixed with the sand. Under the sand is gravel.

The hummocks around the spruce trees have been formed by pigeon wheat moss, and *Sphagnum* is now growing around and over the hummocks. Herbaceous dogwood grows with the *Sphagnum*. Purple marshlock grows with the sedges in the meadow.

Nile Lake peat area

The Nile Lake peat area (16 acres, estimated) is in sec. 35, T. 37 N., R. 42 E., about 6 miles by road southwest of Tiger. It borders the north end of the lake. The elevation of the lake is about 3,650 feet above sea level.

In 1949 and 1950 the peat was covered with water too deep to be waded except at the extreme margin by men in hip boots, and no boring could be done. Evidently the water level was much lower in 1935, when the late

Dachnowski-Stokes examined the area. His record, unpublished so far as known, is, "open body of water, pH 8.0, fringed water lily, a zone of *Comarum palustre* with patches of *Carex filiformis* and bordered by *Spiraea Douglasii*, in a ground cover of *Sphagnum* mosses and *Polytrichum* mosses, sedges, and clumps of red alder. Toward upland portion of the deposit is a meadow of clover, grasses, and strawberry."

The field notes of Dachnowski-Stokes show that in a hole bored near Nile Lake he found, from top to bottom: 1 foot of light-brown to brown to blackish fibrous peat having a pH of 4.0; 2 feet of mixed moss peat and fibrous peat, yellow in color, with some of the fibrous material being felty; 1 foot of a gray-brown mixture of fibrous and sedimentary peat; 12 feet of mixed fibrous, sedimentary, and wood peat that was brown, coarse textured, soft, and waterlogged; 4½ feet of colloidal olive-green sedimentary peat; and 6 inches of light-gray pumicite. The base of the pumicite layer was not found.

The sedge and grass meadow near the north quarter corner of sec. 35 is probably continuous with the peat area bordering Nile Lake. It contains no peat—only muck, diatomite, and pumicite. The deeper one of two holes bored by the writer in this meadow showed 2 feet of mixed muck and diatomite, 14 inches of tan-colored pumicite, and 1 foot of muck which rests on sand.

NORTHERN GROUP

Fence Creek peat area

The Fence Creek peat area (18 acres) is in sec. 22, T. 40 N., R. 43 E., about 7 miles north of Metaline. The road from Metaline to Russian Creek passes close to its western border. Fence Creek flows across the area (map, fig. 137) to the Pend Oreille River. There is a drainage ditch to the creek. Water 6 inches or more deep stands on a large part of the area, which is a sedge meadow with some cattails and knotweeds growing among the sedges.

The one hole bored in this area shows 1 foot of dark-

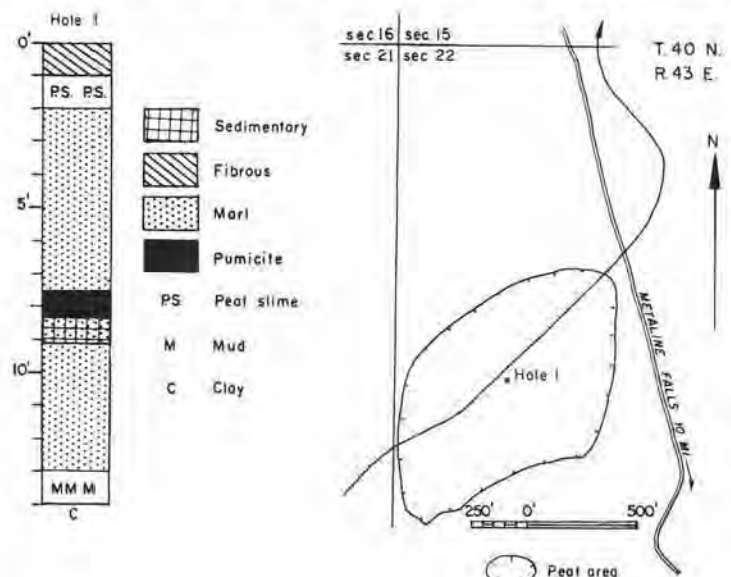

FIGURE 137.—Map and graphic log of a hole in Fence Creek peat area (18 acres). Map adapted from aerial photograph.

brown disintegrated fibrous peat at the surface. Under this is 1 foot of dark-brown peat slime. Under this is 11 feet of marl, which is light gray at the top and bottom but is pale olive near the 9-foot depth, where it is mixed with some sedimentary peat. There are some shells in the upper part of the marl. Under the marl is 1 foot of black mud. Under the mud is 24 feet of soft clay which varies from light gray to dark gray. Under the clay is light-gray sand. At the 8-foot level is a layer of gray pumicite 5 inches thick. The mud and marl immediately above it are neutral (pH 7.0).

Everett Creek peat area

The Everett Creek peat area (less than 5 acres) is in sec. 27, T. 40 N., R. 43 E., about 5 miles north of Metaline, from which it is reached by road. It is on a terrace at an elevation of 2,550 feet above sea level. A steep rocky slope borders it on the south.

It is a sedge meadow on which there is about 1 foot of standing water. Sedges and rushes are abundant, and there are also some bur reed, purple marshlock, knotweed, and water milfoil. Small alder trees are abundant in some places.

This shallow deposit consists of dark-brown fibrous peat resting on blue clay at a depth of 4½ feet. The fibrous peat varies from disintegrated to decomposed and has some sand mixed with it. A 10-inch layer of white pumicite occurs in the third foot from the surface.

PIERCE COUNTY DEPOSITS

Lacamas Creek peat area

Lacamas Creek peat area (262 acres) is in secs. 6, 7, and 18, T. 17 N., R. 3 E., about 4 miles southeast of Roy, and about 15 miles south of Tacoma. Lacamas Creek flows north and west to Muck Lake and thence to the Nisqually River and Puget Sound. The peat lies along the

creek and a tributary. The access to it by roads is shown on the map (fig. 138). It is mapped as shallow Semiahmoo muck over Tanwax peat on the soil map of Pierce County (Anderson et al., 1955).

The profile extends from west to east along a drainage ditch which on August 31, 1950 was moist but contained no water. It is 625 feet south of the north line of sec. 7. Forest on hard land borders the west side of the peat area in the vicinity of hole 1. The vegetation on the peat at this hole consists of grass, rushes, fireweed, and buttercup. Hole 2 is on the border of a barleyfield, and the vegetation along the ditch at this point is composed of hardhack, mint, and buttercup. Hole 3 is also on the border of the barleyfield, and the vegetation along the ditch consists of thistle, fireweed, and buttercup. Hole 4 is on the border of an oatfield, and the vegetation along the ditch is the same as at hole 3. Hole 5 is in a pasture in which grasses, rushes, and buttercups grow.

The materials revealed in the profile (fig. 138) are fibrous peat, wood peat, diatomite, hypnum peat, sedimentary peat, and pumicite. The upper 1 foot of the peat at holes 2 to 5 inclusive has been much modified by cultivation. The fibrous peat is brown to dark brown and disintegrated to decomposed. The hypnum peat is brown and raw. The color of the sedimentary peat varies from olive green to olive brown. The pumicite forms a white layer about 1 inch thick. Marl was found in hole 5 only. Its color is tan. The peat in hole 3 ranges from rather strongly acidic (pH 4.7) at the 2-foot depth to rather weakly acidic (pH 5.5) at the 14-foot depth. The peat in the line of the profile rests on fine gray sand at holes 2, 4, and 5, and on greenish-gray sand at hole 1. At hole 3 it rests on gray clay.

Stuck River peat area No. 1

Stuck River peat area No. 1 (250 acres) is in secs. 11, 12, 13, and 14, T. 20 N., R. 4 E., about 1 mile north of Sumner. It is shown as shallow Semiahmoo muck over

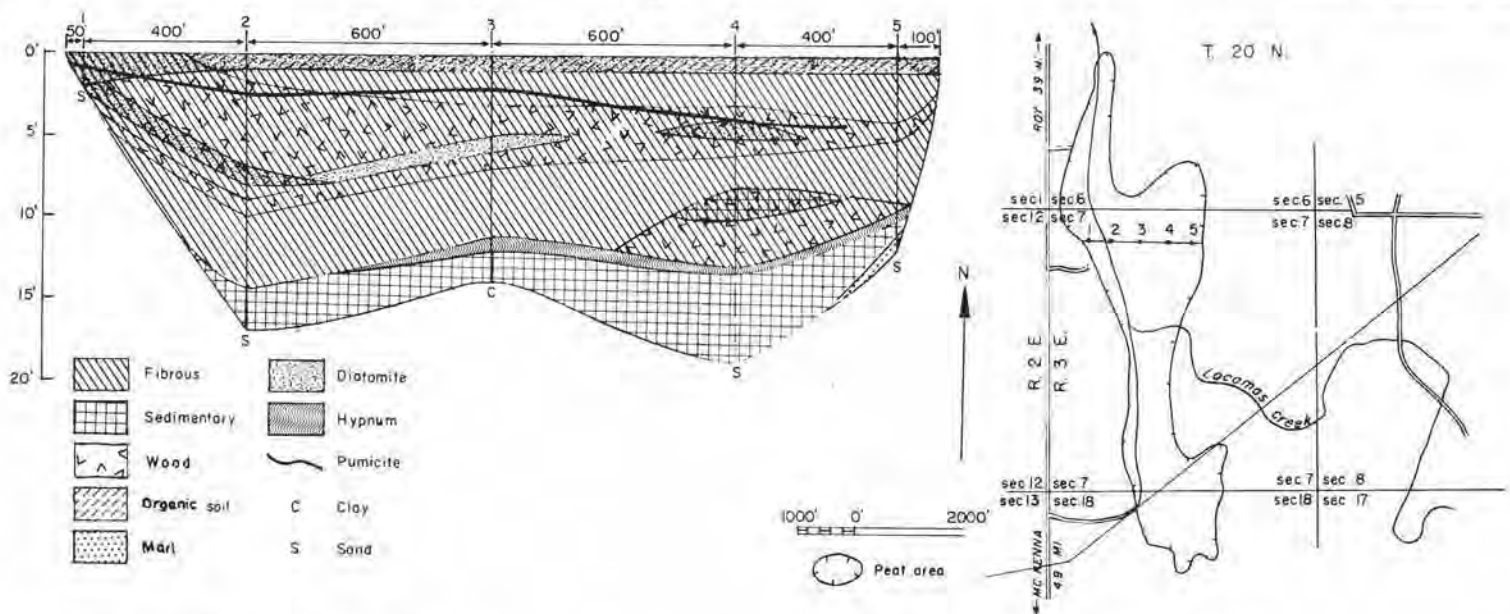

FIGURE 138.—Map and profile of Lacamas Creek peat area (262 acres). Map adapted from U. S. Department of Agriculture soil map of Pierce County.

Mukilteo peat with a little shallow Carbondale muck over Rife peat on the soil map of Pierce County (Anderson et al., 1955). It is about 1½ miles long from north to south and about ½ mile wide (map, fig. 139). It lies in the western part of the valley of the Stuck River, which flows south into the Puyallup River.

The peat is bordered on the west by the steeply sloping hard land, and on the east by the hard land of the very gently sloping valley floor, which slopes westward away from the river toward the valley walls. The eastern border of the peat is about 0.8 mile west of the river. The river has built up low natural levees on both of its banks, preventing surface water from flowing freely from the valley floor to the river. Depressions have thus been left on both the east side and the west side of the valley, and the accumulation of surface water in these depressions has favored the formation of peat. The Stuck River peat area No. 2, in the eastern part of the valley, is discussed under a separate heading.

The formation of peat in river valleys in depressions bordering the neighboring hard land, but not bordering the river, is common in western Washington. Other examples of the formation of peat in depressions of similar origin are found in the valley of the Snoqualmie River in King and Snohomish Counties, and the valley of the South Fork of the Stillaguamish River in Snohomish County.

The Stuck River profile is entirely in cultivated land. The crops in 1950 were beans, rhubarb, and broccoli. Hole 4 is outside of the area mapped as peat, but, as is seen in the profile (fig. 139), there is mineral soil over the peat in the east 700 feet of the profile.

The material shown in the profile is mostly fibrous peat, but there is some muck, wood peat, and sedimentary peat. There is also a fairly large amount of a mixture of sedimentary peat and wood peat with clay, muck, and sand. The fibrous peat is dark brown and disintegrated. In a few places it is compact. The muck is brown, and

the sedimentary peat is olive. The acidity of this peat is close to the borderline between weakly acidic and strongly acidic (pH 4.4 to 5.0). The deposit rests on gray clay and gray sand.

Stuck River peat area No. 2

Stuck River peat area No. 2 (120 acres ?) is probably in secs. 1 and 12, T. 20 N., R. 4 E., and secs. 6 and 7, T. 20 N., R. 5 E. It is in the eastern part of the valley of the Stuck River opposite Stuck River peat area No. 1. The origin of the depression in which it lies has been stated in connection with area No. 1. It is mapped as shallow Semiahmoo muck over Mukilteo peat, and shallow Carbondale muck over Rife peat on the soil map of Pierce County (Anderson et al., 1955).

Dachowski-Stokes investigated this peat in 1935, and all data used in the following discussion are taken from his unpublished field notes.

The peat lies at the foot of a steep escarpment. The cultivated part of the area is mostly in lettuce and peas. The grasses in the pasture part are timothy and red top, among which are some buttercups and ferns.

The kinds of peat and the properties were observed in the bank of an open ditch and by boring "about 6 miles south of Auburn or ½ mile south of the power station." Two layers of peat were found. The upper layer, 9½ feet thick, is fibrous peat, and the lower layer, 1½ feet thick, is sedimentary peat. The fibrous peat is composed of the remains of sedges, and there is some scouring rush peat mixed with it near the bottom of the layer. In color it varies from brown to yellow brown to chocolate brown. Some of it is slightly decomposed and has an odor of hydrogen sulphide. The sedimentary peat is light brown to brownish gray.

The peat is weakly acidic (pH 5.0) near the surface. Its acidity decreases with depth, and at the bottom (11 feet) it is alkaline (pH 8.0). The peat rests on fine gray sand.

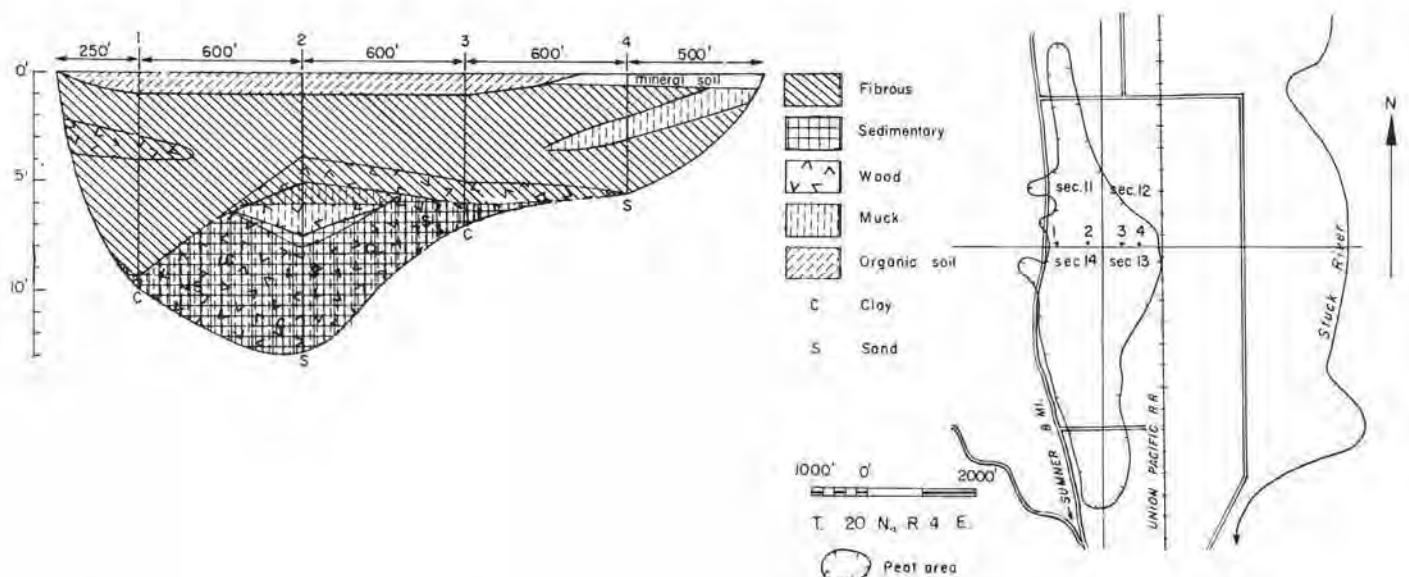

FIGURE 139.—Map and profile of Stuck River peat area No. 1 (250 acres). Map adapted from U. S. Department of Agriculture soil map of Pierce County.

Kreger Lake peat area No. 1

Kreger Lake peat area No. 1 (180 acres) is in secs. 14, 22, and 23, T. 16 N., R. 3 E., about 6 miles west of Eatonville. It is shown as Semiahmoo muck, Mukilteo peat, and shallow Semiahmoo muck over Mukilteo peat on the soil map of Pierce County (Anderson et al., 1955). A drainage ditch extends from the peat to the Nisqually River (map, fig. 140).

A wet mat of vegetation borders the northeast end of the lake. It consists of cattails, willows, water lilies, smartweed, forget-me-not, water cress, and fireweed. Hole 1 of the profile is in this mat. Holes 2 and 3 are in a pasture. At hole 2 the growth of grasses is good, and there are no weeds. At hole 3 the grass is shorter, and clover, plantain, and buttercups grow with it.

The peat revealed in the profile (fig. 140) is in general composed of an upper layer of fibrous peat and a lower layer of sedimentary peat, but there is some mixture of the two kinds at two points in the line of contact. There is also a mixture of woody peat with the fibrous peat at the east end of the profile.

The fibrous peat is brown and varies from coarse and raw to disintegrated to decomposed. The sedimentary peat is olive to olive brown, and in hole 1 it is very soft. The layer of white pumicite near the bottom of hole 1 is only a quarter of an inch thick. The deposit rests on blue clay and sand at holes 1 and 3 and on blue clay at hole 2.

Kreger Lake peat area No. 2

Kreger Lake peat area No. 2 (34 acres) is in the NW¼NW¼ sec. 14, T. 16 N., R. 3 E. It entirely surrounds a small pond (map, fig. 140) about half a mile northwest of Kreger Lake. It is mapped as shallow Semiahmoo muck over Mukilteo peat on the soil map of Pierce County (Anderson et al., 1955).

One hole was bored in a pasture in this area, about 50 feet east of the pond. The vegetation in the vicinity of the hole consists of Labrador tea, bog laurel, *Sphagnum* moss (in patches), grass, aster, mint, and buttercup.

The peat in this hole is 24 feet deep (fig. 140). It consists of 6 feet of fibrous peat, 2 feet of mixed fibrous and

sedimentary peat, and 16 feet of sedimentary peat. The fibrous peat is brown to light brown. Most of it is raw and consists of fine fibers. The sedimentary peat is olive green to olive brown. A layer of white pumicite ½ inch thick is present at a depth of 16 feet. Under the sedimentary peat is 1 foot of blue clay underlain by sand.

Silver Lake peat area No. 1

Silver Lake peat area No. 1 (165 acres) is in secs. 11, 12, and 13, T. 16 N., R. 3 E., about 4 miles northwest of Eatonville. It borders the west and south sides of Silver Lake (map, fig. 141). The peat and the lake lie in a depression in glacial drift. The deposit is mapped as Greenwood peat, deep Mukilteo peat, deep Semiahmoo muck, and shallow Semiahmoo muck over Mukilteo peat on the soil map of Pierce County (Anderson et al., 1955). A small stream from the south side of the lake flows to Kreger Lake and thence to the Nisqually River. The road which parallels the northwest margin of the peat is on land which is considerably higher than the peat.

Hole 1 of the profile is in a pasture in which grass, buttercup, dog fennel, and knotweed grow. Hole 2 is in a sphagnum bog which has an area of about 1 acre. The plants growing in it are Labrador tea, bog laurel, peat-bog birch, sundew, sedges, reeds, and *Sphagnum*. Some of the *Sphagnum* spreads over the flat surface, and some of it forms hummocks. Hole 3 is in a pasture in which buttercups grow with the grasses. Hole 4 is on the lakeshore in a dense growth of cattails and purple marshlocks among which there is some fireweed. Water lilies grow in the lake margin and occasionally among the cattails.

The deposit, as shown in the profile (fig. 141), consists mostly of a single layer of fibrous peat and a single layer of sedimentary peat, but there is some mixture of these and also some sphagnum peat at the surface. The peat soil at the surface in the pastures is dark brown. The fibrous peat is light brown to dark brown and is disintegrated to decomposed. The sedimentary peat is olive to olive green. The layer of pumicite varies from ¼ inch to 1 inch in thickness. It is brown at holes 1 and 3 and

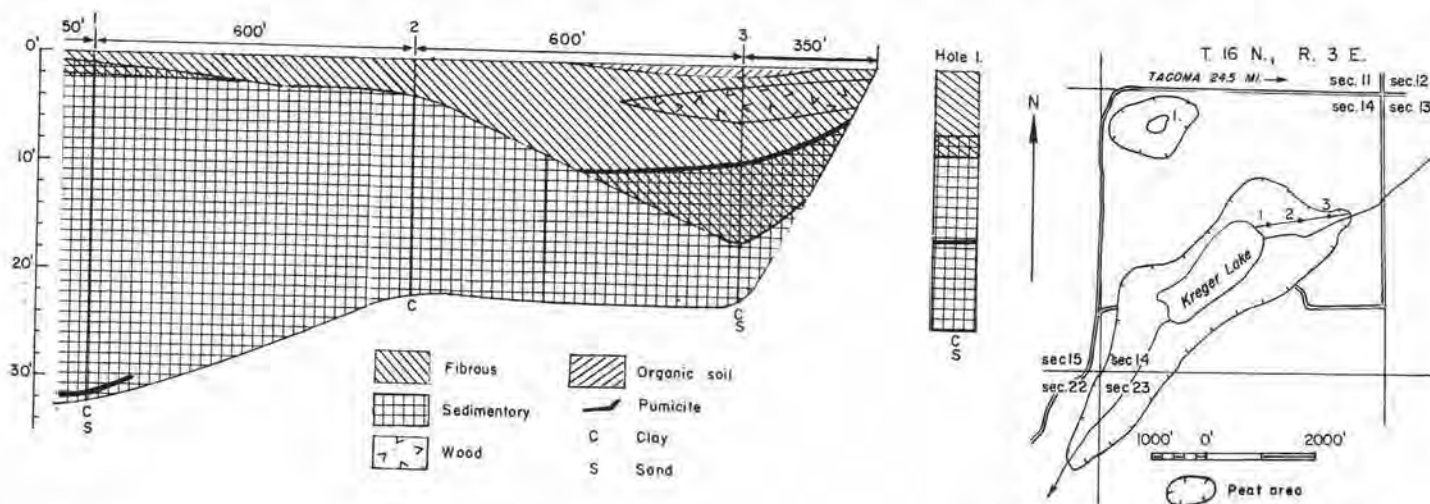

FIGURE 140.—Map, profile, and graphic log of a hole in Kreger Lake peat areas (180 acres and 34 acres). Map adapted from U. S. Department of Agriculture soil map of Pierce County.

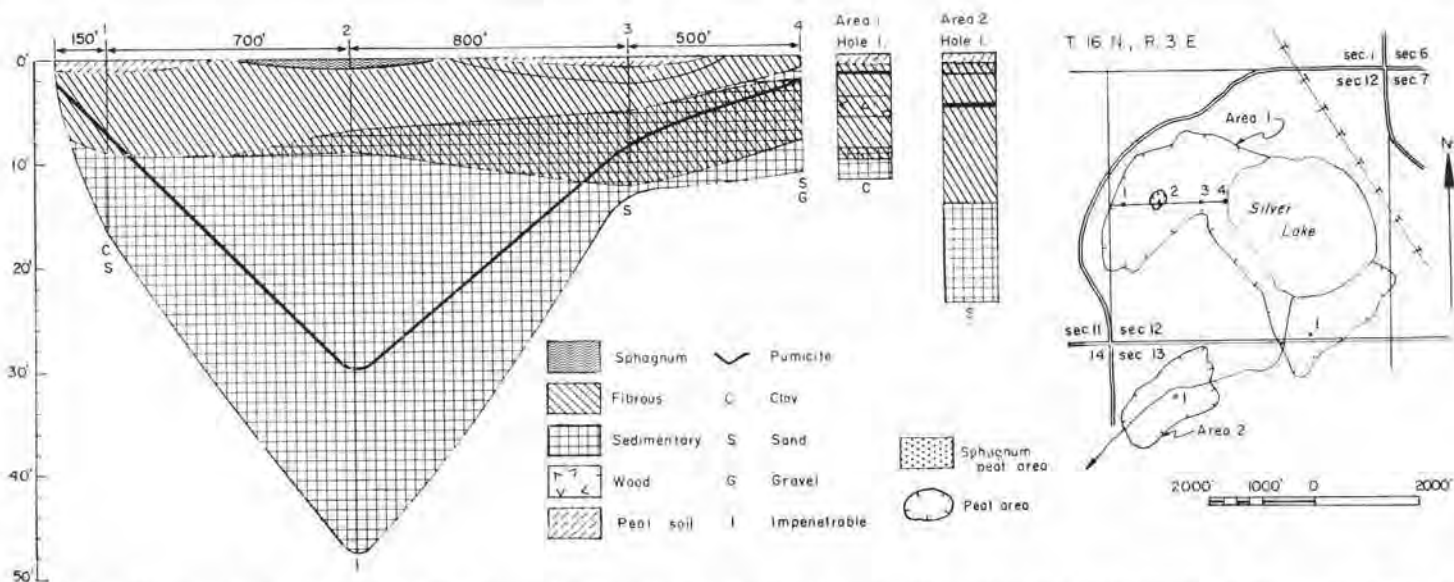

FIGURE 141.—Map, profile, and graphic logs of two holes in Silver Lake peat areas, Pierce County (165 acres and 48 acres). Map adapted from U. S. Department of Agriculture soil map of Pierce County.

white at holes 2 and 4. The deposit rests on sand, gravel, and soft blue clay. The sedimentary peat at the 48-foot depth in hole 2 is too compact to be bored deeper.

One hole was bored about 50 feet north of the road in an oatfield. The fibrous peat and sedimentary peat in this hole are similar to the same material found in the profile. The mixture of fibrous peat and wood peat is brown. The pumicite is tan. The pH at the 1-foot depth is 4.5, and at the 10-foot depth it is 6.2. Here the peat rests on blue clay.

Silver Lake peat area No. 2

Silver Lake peat area No. 2 (48 acres) is in sec. 13, T. 16 N., R. 3 E., less than half a mile southwest of Silver Lake. It does not border the lake (map, fig. 141), but it does border the creek that flows from Silver Lake to Kreger Lake. The peat lies in a depression in glacial drift. The peat is mapped as Semiahmoo muck on the soil map of Pierce County (Anderson et al., 1955).

One hole (fig. 141) was bored in a hayfield. The peat soil is brown. The fibrous peat is light brown to dark brown. The mixture of fibrous peat and diatomite is dark brown. The sedimentary peat is dark green to olive brown. The pumicite is tan, and it is in a layer half an inch thick. The peat is weakly acidic. The pH of the mixture of fibrous peat and diatomite at the 2-foot depth is 5.0, and that of the mixture of sedimentary and fibrous peat at the 20-foot depth is 6.2. The deposit rests on sand.

Mud Lake peat and muck deposit

The Mud Lake peat and muck deposit (135 acres) is located in secs. 28, 32, and 33, T. 17 N., R. 4 E. It is about 18 miles south of Puyallup and about 6 miles northwest of Eatonville. The area lies between two highways, and is easily accessible from a road which extends near its north side.

Mud Lake is shown on the Ohop Valley quadrangle. Its elevation is 623 feet above sea level. A creek whose water eventually reaches the Nisqually River flows west-

ward from the lake. Near the lake the bed of this creek has been straightened and perhaps deepened to facilitate drainage.

The deposit is shown on the soil map of Pierce County (Anderson et al., 1955). It consists of 11½ acres of Tanwax peat, 19½ acres of Mukilteo peat, and 104 acres of Semiahmoo muck (map, fig. 142). The surface of the surrounding hard land is mostly undulating, and the soil is mostly gravelly or loamy (Anderson et al., 1955). The Mukilteo peat area west of the lake is in use for the production of hay. Hole 1 is in this hayfield. Hole 2 is 50 feet west of the west margin of the lake in the brushy part of the mat of vegetation which surrounds the lake. Nearer the lake the vegetation is herbaceous.

Determination of color and pH of the materials in this deposit were made in the field^① by the use of apparatus and procedure which yield more accurate data than those obtained in other deposits covered in this bulletin. The colors of the peat were determined by comparison with a modified Munsell color chart (Soil Survey staff, 1951). The pH was determined by the use of a portable glass electrode pH meter.

Six determinations of color and pH were made on materials found in hole 1 (profile, fig. 142). The color determinations were made on moist material. The color of peat changes more or less as it dries.

The color of the layer of muck which extends from the surface to the 14-inch depth is very dusky red, and its pH is 5.2. The color of the layer of partially disintegrated fibrous peat mixed with sedimentary peat which extends from the 14-inch depth to the 4-foot depth varies from dark yellowish brown to dark brown, and its pH is 5.6. The color of the layer of raw fibrous peat which extends from the 4-foot depth to the 8-foot depth varies

^① The determinations were made in the field in the course of soil survey work by the U. S. Soil Conservation Service. The determinations were made by J. E. Dawson, Professor of Soil Science at Cornell University. F. E. Schlots of the Soil Conservation Service and G. B. Rigg, who at that time was a consulting botanist in the Soil Conservation Service, were also members of the party.

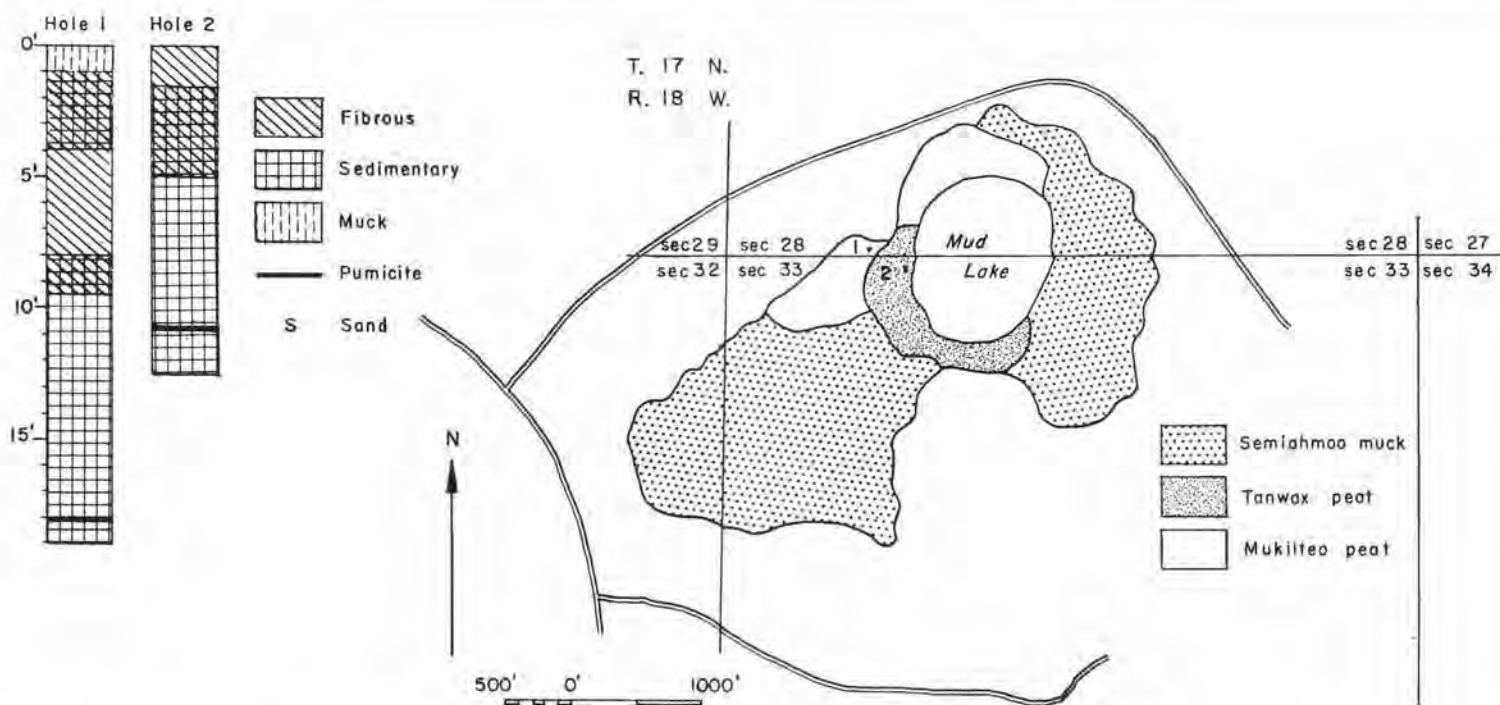

FIGURE 142.—Map and graphic logs of two holes in Mud Lake peat and muck deposit (135 acres). Map adapted from U. S. Department of Agriculture soil map of Pierce County.

from dark yellowish brown to very dark grayish brown, and its pH is 5.7. The color of the layer of fibrous peat mixed with sedimentary peat which extends from the 8-foot depth to the 8¾-foot depth⁵ varies from dark yellowish brown to very dark grayish brown, and its pH is 6.2. The color of the sedimentary peat mixed with fibrous peat which extends from the 8¾-foot depth to the 9½-foot depth varies from reddish brown to dark reddish brown, and its pH is 6.1. The color of the layer of sedimentary peat which extends from the 9½-foot depth to the 19-foot depth varies from dark brown to very dark grayish brown, and its pH is 6.1.

Four determinations of color and pH were made on materials found in hole 2 (profile, fig. 142). The color of the layer of disintegrated fibrous peat⁶ which extends from the surface to the 3-inch depth is black, and its pH is 4.6. The color of the layer of disintegrated fibrous peat which extends from the 3-inch depth to the 20-inch depth is yellowish red, and its pH is 5.2. The color of the layer of sedimentary peat mixed with fibrous peat which extends from the 20-inch depth to the 5-foot depth is dark brown, and its pH varies from 5.2 to 5.7. The color of the layer of sedimentary peat which extends from the 5-foot depth to the 12½-foot depth is dark brown, and its pH is 6.2.

South Creek peat area

The South Creek peat area (132 acres) is in secs. 32 and 33, T. 18 N., R. 4 E., and sec. 5, T. 17 N., R. 4 E., about 4 miles west of Kapowsin and about 9 miles southwest of

Orting. It is mapped as Semiahmoo muck over Mukilteo peat on the soil map of Pierce County (Anderson et al., 1955). Drainage has been provided by straightening, widening, and deepening South Creek so that it is now a drainage ditch (map, fig. 143) which carries water to Muck Creek and eventually reaches the Nisqually River and Puget Sound.

The profile is based on two holes which are in a pasture. Hole 2 is near the drainage ditch where grass and clover thrive.

Only two kinds of peat (fibrous and sedimentary) are shown in the profile (fig. 143). The fibrous peat is brown to dark brown, and much of it is decomposed. The sedimentary peat is olive to olive green. The peat soil, which constitutes the upper foot of the deposit, is brown. At hole 1 it is mixed with diatomite, and at hole 2 it is very dry.

The pumicite in hole 1 is white, and the layer is 3 inches thick. At hole 2 it is brown, and the layer is 1 inch thick. The layer is comparatively close to the surface, indicating that a relatively small amount of peat has been formed since the volcanic eruption which deposited this ash.

If, as seems warranted, we assume that the volcanic eruption which deposited the pumicite in the South Creek area also deposited the pumicite in the Kreger Lake area (fig. 140) and the Silver Lake area (fig. 141), which are less than 10 miles distant, interesting comparisons may be made of peat formation in these three areas during the time that has elapsed since the eruption.

This peat deposit rests on fine gray sand, but in hole 2 an 11-inch layer of blue clay lies between the peat and the sand.

⁵ In the profile (fig. 142) this layer and the next one below it are shown as one layer.

⁶ Because of the extreme thinness of this layer it is shown in the profile with the next layer below it.

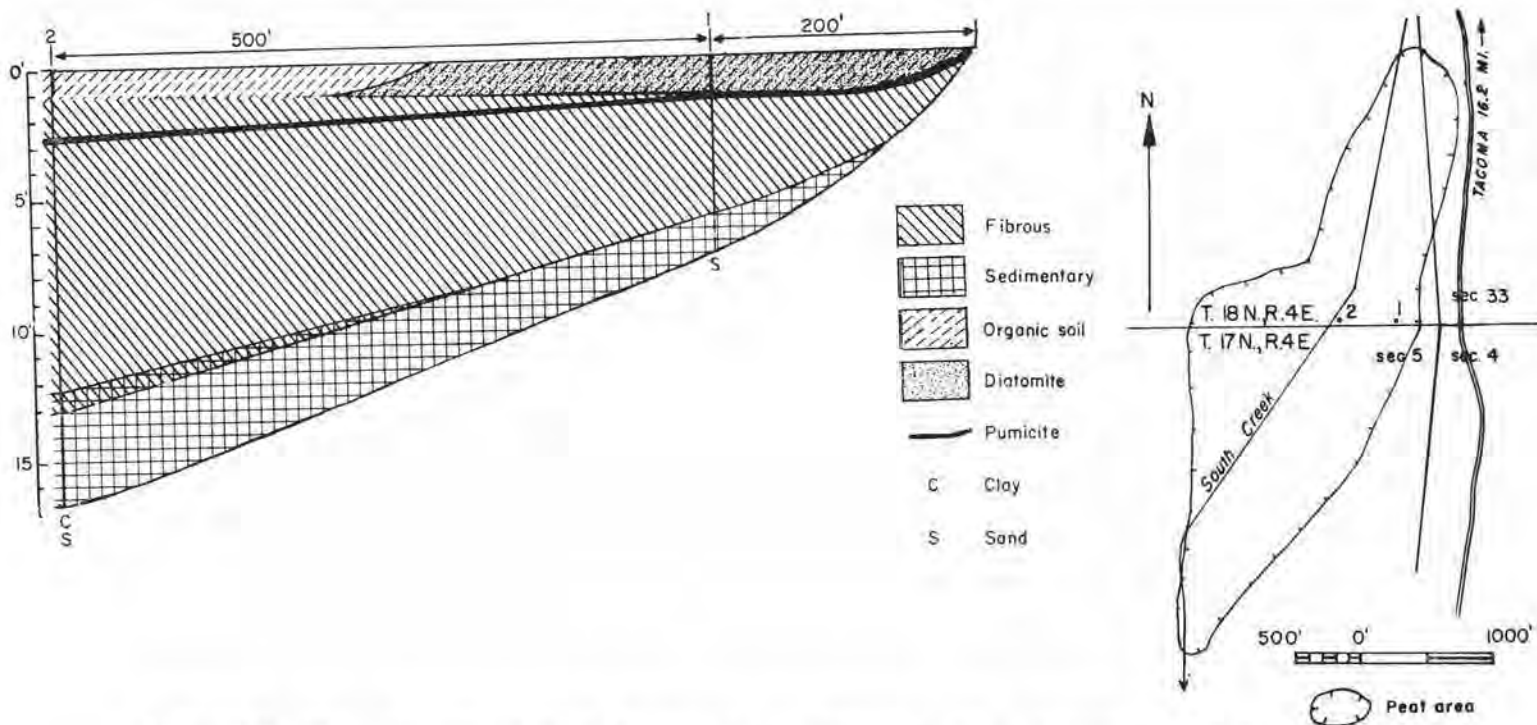

FIGURE 143.—Map and profile of South Creek peat area (132 acres). Map adapted from U. S. Department of Agriculture soil map of Pierce County.

Clover Creek peat area

Clover Creek peat area (120 acres) is in secs. 7, 8, 17, and 18, T. 19 N., R. 3 E., about 2 miles southwest of Parkland and perhaps 3 miles south of the city limits of Tacoma. It lies in a depression in glacial drift. It is mapped as Mukilteo peat and Semiahmoo muck over Tanwax peat on the soil map of Pierce County (Anderson et al., 1955). Clover Creek now flows across the peat area in a drainage ditch (map, fig. 144). The area south of the ditch is largely swamp forest, and the area north of the ditch is mostly pasture. The plants growing along the ditch are willows, hardhack, grasses, and mint.

The deposit, so far as the profile reveals it (fig. 144), consists mainly of a thick layer of fibrous peat with a thick layer of sedimentary peat under it in the deepest part, though there is also a considerable amount of diatomite. There is also some wood peat mixed with fibrous peat and some clay mixed with the sedimentary peat at the bottom of hole 2.

The fibrous peat is brown to dark brown and is mostly decomposed, though some of it is merely disintegrated. The sedimentary peat is olive colored. The layer of pumicite is 1 inch thick at holes 1, 2, 3, and 5. It was not found at hole 4, but it may be mixed with the diatomite there, and in constructing the profile a straight line representing the ash was drawn from hole 3 to hole 5. The pumicite is brown at holes 1, 2, and 5, and tan at hole 3. The deposit, so far as shown by the profile, rests on gravel and clay.

Sovereign (1934) investigated the diatomite of this bog. He says, "This bog deposit is located about a mile west of the town of Parkland on the Rainbow Ranch in sec. 8, T. 19 N., R. 3 E., and has been explored over an extent of 20 acres area and to varying depths up to 20

feet and is thought to be still deeper in some parts. It has been conservatively estimated to contain about 20,000 tons [on a calcined basis] of material of good grade on the basis of an average depth of 15 feet. This deposit contains a high amount of carbonaceous matter and would have to be calcined. . . . The iron content is low. . . . A microscopic examination shows a wide assortment of sizes and forms of the usual bog species, the diatoms in general being unbroken, with an extraordinary number of siliceous spicules of fresh water sponges."

Hansen (1938) investigated this bog, and made borings in sec. 7. He found 10.5 meters (34 feet 5 inches) of peat resting on blue clay. The bottom 3.5 meters (11 feet 6 inches) is slightly fibrous sedimentary peat. The next 3.6 meters (11 feet 10 inches) is slightly oxidized sedge peat. Above this is 0.8 meter (2 feet 7 inches) of sedimentary peat. The top layer, 2.6 meters (8 feet 6 inches) thick, is less oxidized peat and grades into raw peat. The pumicite layer is present at the 2.8-meter (9-foot 2-inch) horizon.

Cranberry Lake peat area

The Cranberry Lake peat area (115 acres, including 11 acres of sphagnum) is in sec. 1, T. 16 N., R. 3 E., and sec. 6, T. 16 N., R. 4 E., about 5 miles northwest of Eatonville. It surrounds Cranberry Lake, and the sphagnum bog borders the west side of the lake (map, fig. 145). State Highway 5 (Tacoma to Mount Rainier National Park) crosses the eastern part of the area about 12 miles south of Tacoma, and the electric transmission line from La Grande to Tacoma crosses the southwestern part. The peat is shown on the soil map of Pierce County (Anderson et al., 1955) as Greenwood peat, Mukilteo peat, and Semiahmoo muck over Mukilteo peat. The elevation of

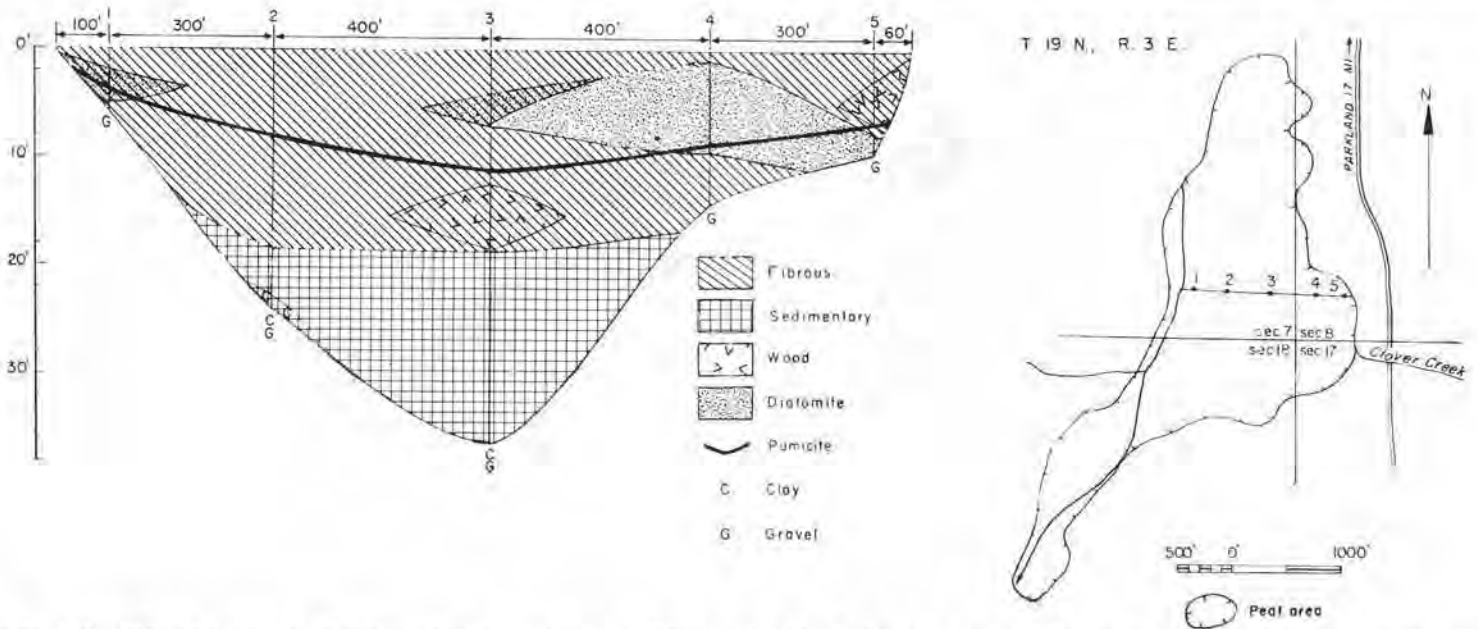

FIGURE 144.—Map and profile of Clover Creek peat area (120 acres). Map adapted from U. S. Department of Agriculture soil map of Pierce County and U. S. Army Map Service photomosaic.

the lake is 644 feet above sea level. The lake and the peat occupy a depression in glacial drift.

The profile (1,050 feet long) extends from the border of a coniferous forest to the border of the lake. In the vicinity of holes 1 and 2 the vegetation consists mostly of sedges and reeds, but some fireweed occurs near hole 1, and mint, near hole 2. Hole 4 is in the sphagnum bog, in which the vegetation consists largely of Labrador tea, peat-bog birch, and lodgepole pine. At hole 3 the same species occur, but hardhack and bracken fern are also common.

The deposit (fig. 145) consists mainly of moss peat, fibrous peat, sedimentary peat, and mixtures of the latter two. The layer of sand in hole 2 is wet. The mixture of clay and sedimentary peat at the bottom of hole 4 is greenish gray. The fibrous peat is brown to dark brown and disintegrated to decomposed. The sedimentary peat is light olive green to light olive brown. At the 28-foot

depth it has a sour odor. The pumicite is brown at hole 2 and tan at hole 3. It is in a layer 1/2 to 1 inch thick.

The sphagnum at the surface consists of whole stems with leaves attached, but progressive disintegration begins at a depth of 1 foot, and at the bottom (8 feet) disintegration is complete. The sphagnum is strongly acidic (pH 4.0), the fibrous peat is slightly less strongly acidic (pH 4.7), and the sedimentary peat is weakly acidic (pH 5.0 to 5.3).

The deposit rests on blue clay. At hole 3 the layer of clay is only 6 inches thick and is underlain with gravel.

A wire mesh fence surrounds part of the bog and the lake. It was learned locally that a muskrat farm, now abandoned, had formerly been established there.

McKenna Road peat area No. 1

McKenna Road peat area No. 1 (117 acres, including 2 acres of sphagnum) is in secs. 20, 21, and 29, T. 17 N.,

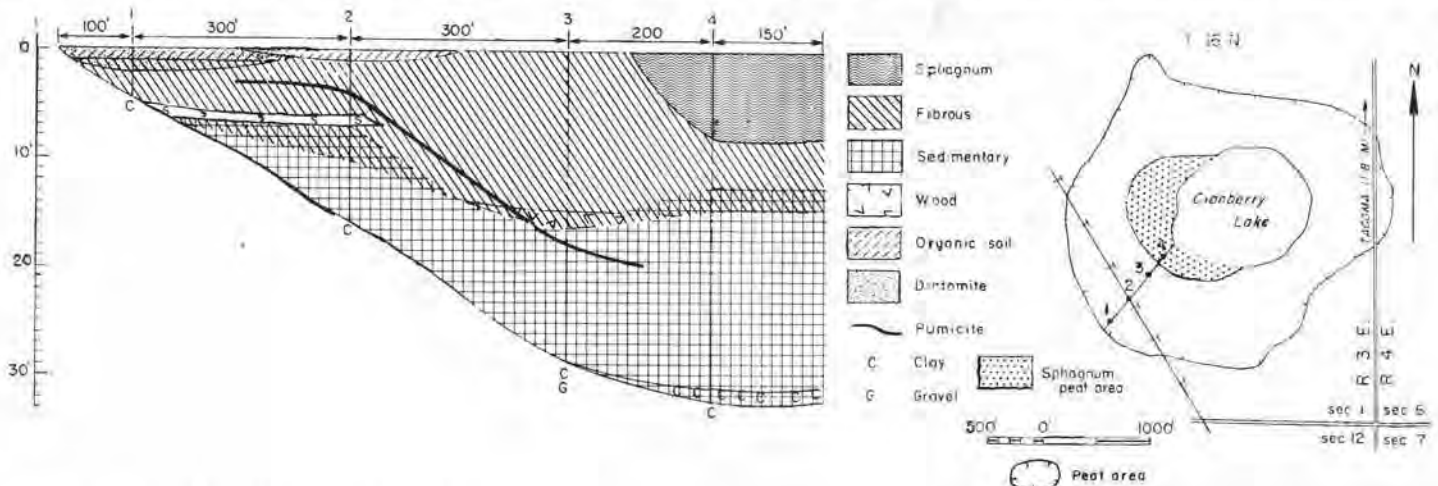

FIGURE 145.—Map and profile of Cranberry Lake peat area, Pierce County (115 acres, including 11 acres of sphagnum). Map adapted from U. S. Department of Agriculture soil map of Pierce County.

R. 3 E., about 5 miles east of McKenna and about 18 miles south of the south city limits of Tacoma. The road from McKenna crosses the central part of the area (map, fig. 146). The deposit lies in an elongated depression in glacial drift, and is shown on the soil map of Pierce County (Anderson et al., 1955) as Mukilteo peat, Rifle peat, and Semiahmoo muck over Mukilteo peat.

Hole 1 of the profile is in a brushy swamp, holes 3 and 4 are in a sphagnum bog, and hole 2 is in the transition zone from the swamp to the bog. Hole 5 is in a swamp forest. A small creek flows near hole 1, and the surface in the vicinity of the hole is very soft. The plants there are hardhack and skunk cabbage, with duckweed in the pools. Willow and alder (mostly dead) are also present. The flora at hole 2 is composed of alder, Labrador tea, ninebark, cattails, and purple marshlocks. At hole 3 *Sphagnum* is growing vigorously and has formed some hummocks. Other plants there are cranberry, sundew, skunk cabbage, cattails, alder, cedar, and hemlock. *Sphagnum* also grows at hole 4. With it are Labrador tea, buckbean, sedges, skunk cabbage, cedar, and hemlock. At hole 5 the swamp forest consists of cedar and hemlock with an undergrowth of salal, salmon berry, and skunk cabbage.

The peat in this deposit (fig. 146) is mostly fibrous, but mixtures of fibrous peat and woody peat occur. Some logs were encountered in hole 3. The small amount of sphagnum is mostly pure, but some of it is mixed with fibers of other plants. The fibrous peat is brown to dark brown and disintegrated to decomposed. The muck is black. The mixture of diatomite and muck is dark gray.

McKenna Road peat area No. 2

McKenna Road peat area No. 2 (106 acres) is in secs. 20 and 29, T. 17 N., R. 3 E., about 4½ miles east of McKenna and about 900 feet west of McKenna Road peat area No. 1. McKenna Road crosses the center of the area.

The peat is mapped as Mukilteo peat, Rifle peat, and Semiahmoo muck over Tanwax peat on the soil map of Pierce County (Anderson et al., 1955).

The profile is in a pasture where some weeds grow with the grasses. The deposit, so far as revealed by the profile (fig. 146), consists mostly of fibrous peat which is dark brown in color and ranges from disintegrated to decomposed. The diatomite in holes 1 and 2 is tan colored. The mixture of sedimentary peat and fibrous peat at the bottom of the deposit is olive in color. The layer of tan pumicite is three-quarters of an inch thick. The deposit rests on gray sand and gray clay.

Spanaway Lake peat area No. 1

Spanaway Lake peat area No. 1 (54 acres) is in sec. 29, T. 19 N., R. 3 E., about 3 miles south of Parkland. The area is mapped as Mukilteo peat on the soil map of Pierce County (Anderson et al., 1955). It borders the west shore of the lake, but there is an "island" of hard land bordering the lake and the peat (map, fig. 147).

The profile extends from this "island" to the west margin of the peat. Hole 1 is in a dense growth of hardhack, in which there is also a scattered growth of sedge, gentian, and grass. Hole 2 is in a young stage of a sphagnum bog. *Sphagnum* grows in patches and is spreading. The woody plants are Labrador tea, peat-bog birch, crab apple, and hardhack. Arctic star flower, a characteristic bog herb in the Puget Sound region, also occurs.

This deposit (fig. 147) consists mostly of fibrous peat, but there are two layers of hypnum peat, and there is also a thin layer of sedimentary peat at the bottom of the deepest hole. The fibrous peat is brown to dark brown and is raw to disintegrated to decomposed. The hypnum peat is light brown to brown, and most of it is raw, though some of it is disintegrated. The sedimentary peat is olive green. The pumicite is brown. It forms a layer 1 to 1½ inches thick. The deposit rests on sand and gravel.

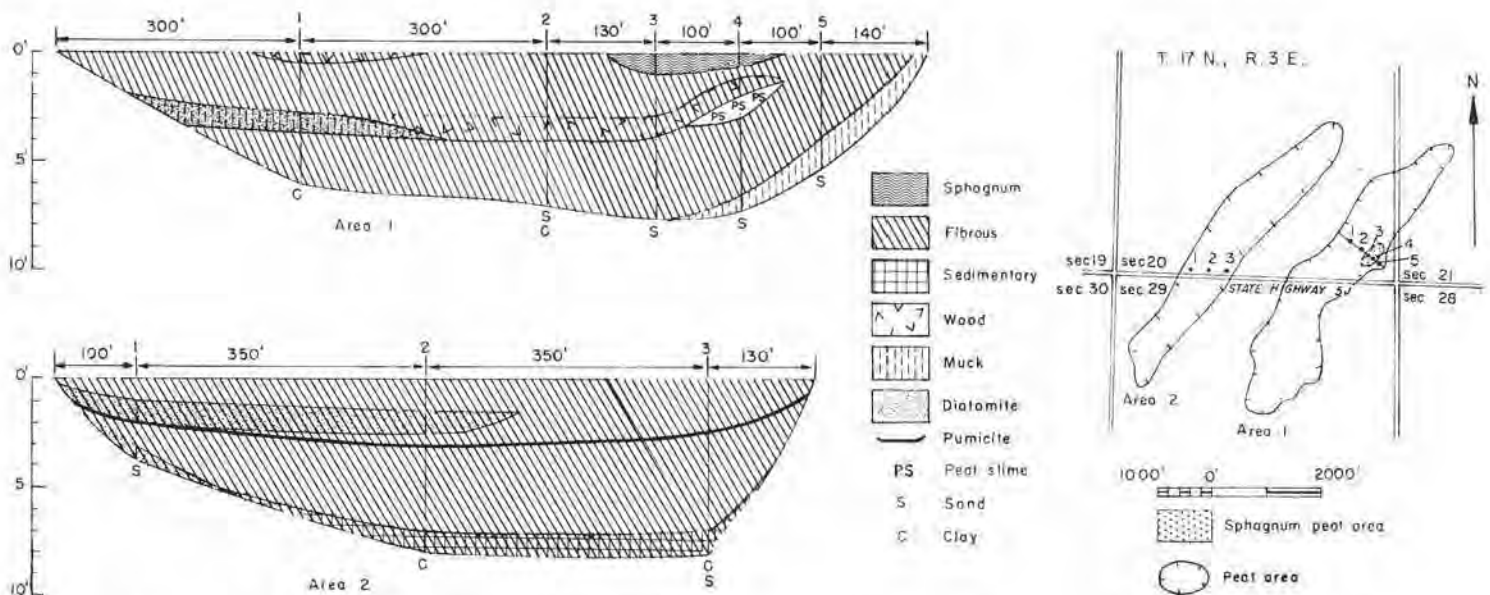

FIGURE 146.—Map and profiles of McKenna Road peat areas (117 acres and 106 acres). Map adapted from U. S. Department of Agriculture soil map of Pierce County.

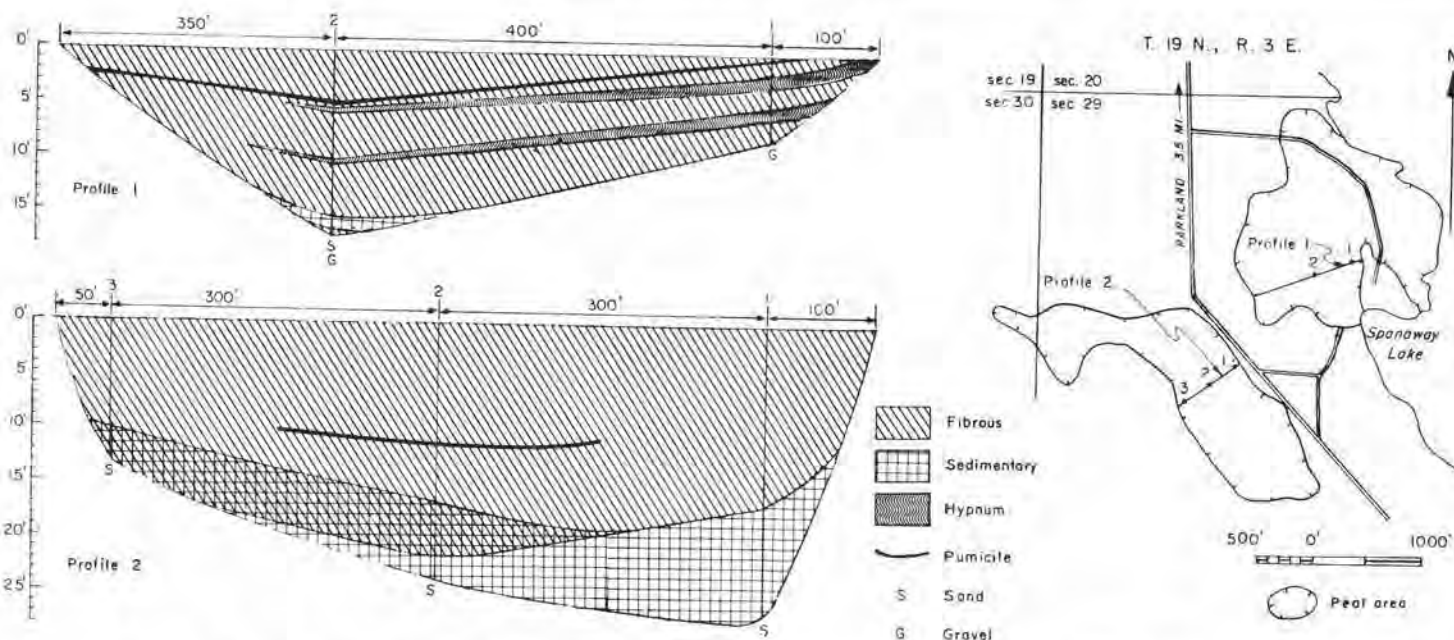

FIGURE 147.—Map and profiles of Spanaway Lake peat areas (54 acres and 46 acres). Map adapted from U. S. Department of Agriculture soil map of Pierce County.

Spanaway Lake peat area No. 2

Spanaway Lake peat area No. 2 (46 acres) is in secs. 29 and 30, T. 19 N., R. 3 E. At the nearest point it is less than 500 feet from Spanaway Lake peat area No. 1. The road leading north to Parkland extends between the two areas (map, fig. 147).

Though this is a rather deep bog (26½ feet), the sphagnum succession in it is young, and no sphagnum peat has been formed. The surface of the bog is dry, and the growth of *Sphagnum* is sparse. There are some thickets of peat-bog birch and some of crab apple, but in other places the growth of woody plants (Labrador tea, bog laurel, hardhack, peat-bog birch, and crab apple) is sparse. Some sundew occurs with the *Sphagnum*.

The layer of fibrous peat, which constitutes the major part of this deposit (fig. 147), has an extreme depth of 19 feet. The layer of sedimentary peat under the fibrous peat is 10 feet deep in the deepest place in the profile. The fibrous peat is light brown to dark brown and is disintegrated. The sedimentary peat is olive to dark green. The pumicite in hole 2 is brown. It forms a layer ½ to 1 inch thick. A comparison of the amount of peat formed before and after the eruption from which the pumicite came in the two Spanaway Lake deposits is readily made by comparing the two profiles. The deposit rests on gray sand.

Milton peat area No. 1

Milton peat area No. 1 (53 acres) is in sec. 5, T. 20 N., R. 4 E., just east of Milton, which is on U. S. Highway 99 about 5 miles east of Tacoma. A road, leading east from U. S. Highway 99 on the curve 1 mile east of Fife, crosses the peat (map, fig. 148). The peat lies in a slight depression formed by the damming of the Hylebos Creek valley at its mouth as a result of the aggradation of the main valley (Puyallup Valley) by the Puyallup River. It is mapped as Semiahmoo muck, Carbondale muck, and Sem-

iahmoo muck over Mukilteo peat on the soil map of Pierce County (Anderson et al., 1955).

This is a wet area, brushy in some places and open in others. The woody growth consists of hardhack, willows, and elderberry. The herbaceous growth includes cattails, water celery, dock, smartweed, and swamp ferns.

The deposit consists of fibrous peat, woody peat, sedimentary peat, muck, and mixtures of these materials (fig. 148). The fibrous peat varies from light brown to dark brown and from raw to disintegrated, and some of it is mucky. The sedimentary peat is light olive to olive. The deposit rests on gray to greenish-gray mud and silt.

Two holes, drilled in July 1957 near the center of the SW¼NW¼ sec. 5, T. 20 N., R. 4 E., by engineers of the Washington State Highway Department, are about half a mile north of the location in the same section where five holes were bored in the Milton peat area during the peat investigation by the State Division of Mines and Geology. It will be noted that the two holes (fig. 149) differ from the five holes (fig. 148) in that the two have (1) much greater depth, (2) greater number of layers of peat, (3) greater number of layers of mineral material, and (4) the occurrence of layers of peat overlain by mineral material. A comparison of the profiles of the two holes with those of the five holes suggests that in river valley deposits which have been investigated by the use of the New American peat borer there may have been layers of peat which were not found because they were overlain by mineral material which the borer did not penetrate. It seems probable, for instance, that at the two locations examined by the engineers, if the holes had been made with the peat borer they would have bottomed at the 16-foot depth because of the layer of clay, and that the layers of peat lying below this depth would not have been found. The various layers of material in these two holes record the numerous changes in conditions which

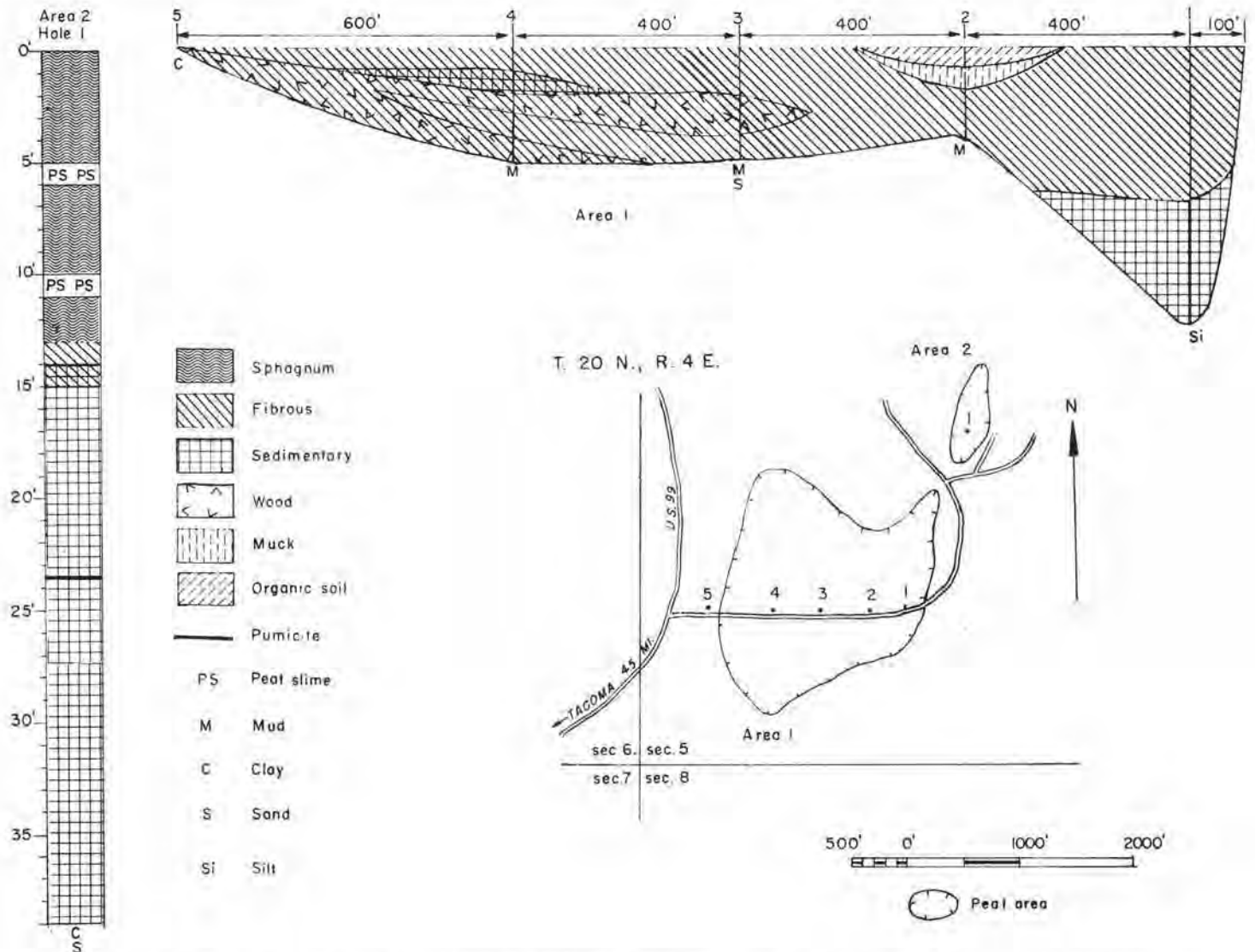

FIGURE 148.—Map, profile, and graphic log of a hole in Milton peat areas (53 acres and 5 acres). Map adapted from U. S. Department of Agriculture soil map of Pierce County.

have occurred during the time that has elapsed since the retreat of the Vashon ice about 6,700 years ago.

Milton peat area No. 2

Milton peat area No. 2 (5 acres) is in sec. 5, T. 20 N., R. 4 E., only a few hundred feet northeast of Milton peat area No. 1 (map, fig. 148). It lies in a small valley tributary to Hylebos Creek valley, in which is the Milton peat area No. 1, and it owes its origin to the same conditions as those responsible for the peat in area No. 1.

This is a sphagnum bog which is rather dry at the surface but is very wet at a depth of 1 foot. The usual sphagnum bog shrubs and herbs are abundant. Peat-bog birch is common around the margin, and it and small alder trees grow on the bog.

The deposit is much deeper than the neighboring larger bog (fig. 148). It consists of sphagnum peat, peat slime, fibrous peat, and sedimentary peat, with some mixture of the latter two.

The sphagnum near the surface is raw, but at greater depths it is disintegrated. It varies from light brown to brown. It is wet, and there are two layers of peat slime in it. The fibrous peat, small in amount, is fine textured, brown, and disintegrated. The sedimentary peat is olive to olive brown. The pumicite is white and forms a layer 1 inch thick. The peat varies from strongly acidic (pH 4.8 in sphagnum at the 1-foot depth) to weakly acidic (pH 5.4 in sedimentary peat at 18 feet). The deposit rests on blue clay which contains some sand.

There was a small commercial cranberry bog on this peat about 30 years ago, but it was abandoned. A small amount of peat has been removed from this bog and marketed during recent years. Commercial utilization of the sphagnum in this bog seems possible. The amount available, ready access by road, and nearness to markets are favorable factors. The high water content and the disintegrated condition of some of the material are unfavorable factors to be considered, however.

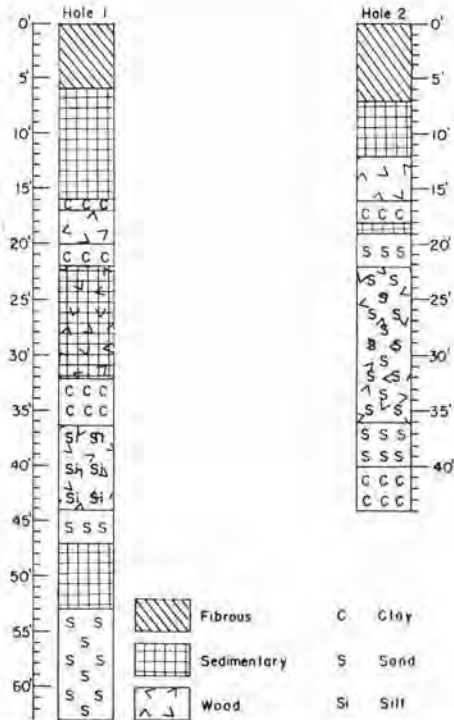

FIGURE 149.—Graphic logs of two holes north of Milton peat area No. 1.

Harts Lake peat area

Harts Lake peat area (43 acres) is in secs. 7 and 8, T. 16 N., R. 3 E., about 6 miles by road southeast of McKenna and about 1 mile east of the Nisqually River. It borders the southeast shore of Harts Lake and has two "islands" of hard land in it (map, fig. 150). It is mapped as Rifle peat on the soil map of Pierce County (Anderson et al., 1955). The lake and the peat area lie in a depression in glacial drift.

Holes 1, 2, and 3 of the profile are in a grass pasture. Mint covers the ground at hole 4, and between holes 3 and 4 the ground cover is mostly sedge. Alder, willow, and

dogwood form a rather dense growth between hole 4 and the lake shore, and cattails and willows grow in the margin of the lake.

This deposit (fig. 150) consists mainly of mixtures of diatomite and muck, diatomite and fibrous peat, woody peat and fibrous peat, and sedimentary peat and fibrous peat. The amounts of pure fibrous peat and pure sedimentary peat are relatively small, and hypnum peat is found only in hole 3. The mixtures of diatomite and muck and of diatomite and fibrous peat are brown. The mixture of fibrous peat and woody peat is dark brown. The mixture of fibrous peat and sedimentary peat is olive brown. The fibrous peat is dark brown and disintegrated. The hypnum peat is light brown and raw. The deposit rests on gray sand.

Parkland peat area

Parkland peat area (38 acres) is in secs. 5, 6, 7, and 8, T. 19 N., R. 3 E., about 1 mile west of Parkland and about the same distance east of U. S. Highway 99. The road from Parkland to U. S. 99 crosses the peat (map, fig. 151). The deposit is mapped as Mukilteo peat on the soil map of Pierce County (Anderson et al., 1955). This peat was formed in a lake which occupied a relatively deep depression in the gravelly outwash from the retreating Vashon ice.

Hole 1 of the profile is in a grass pasture in which some water lilies still remain as a remnant of the old lake vegetation. Hole 2 is beside the pond from which peat is being excavated. The vegetation is a sparse growth of willows, grass, and mint. At hole 3 the surface has been stripped bare and the peat is dry and cracked. Hole 4 is in a pure stand of hardhack.

The surface layer of fibrous peat (fig. 151) is brown to dark brown, disintegrated to decomposed, and rather strongly acidic (pH 4.5). The sedimentary peat forming the bottom layer is olive to olive green and is weakly acidic (pH 5.3). The mixture of fibrous peat and sedimentary peat overlying the sedimentary peat is mostly

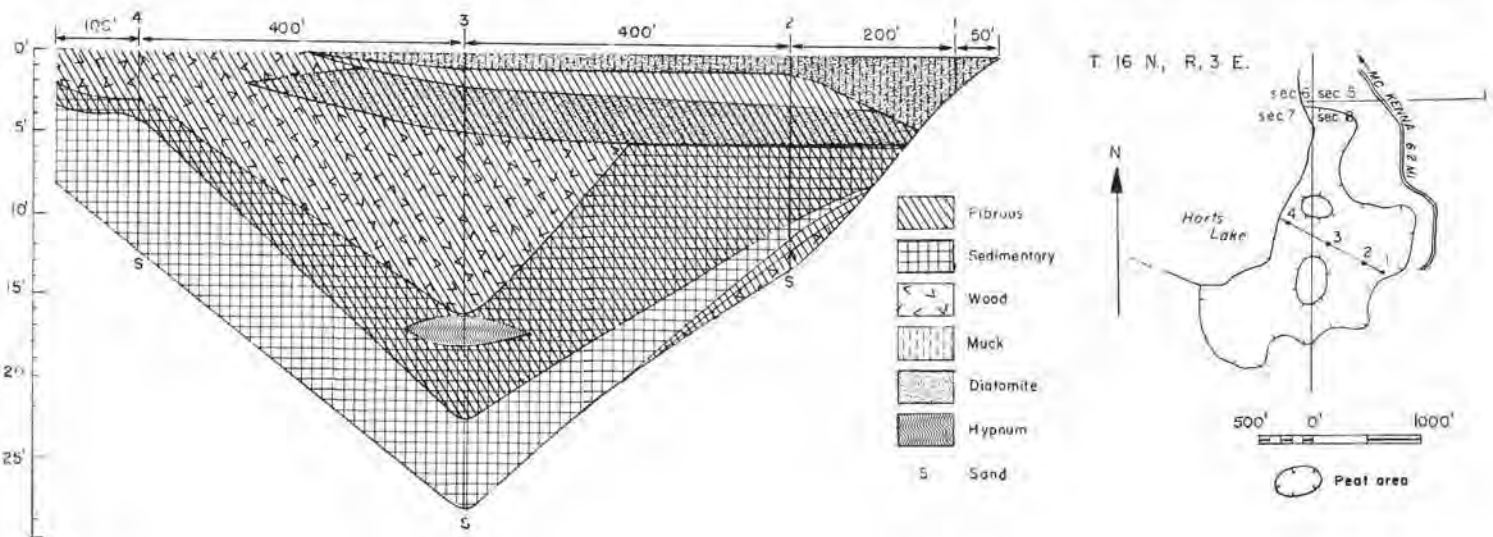

FIGURE 150.—Map and profile of Harts Lake peat area (43 acres). Map adapted from U. S. Department of Agriculture soil map of Pierce County.

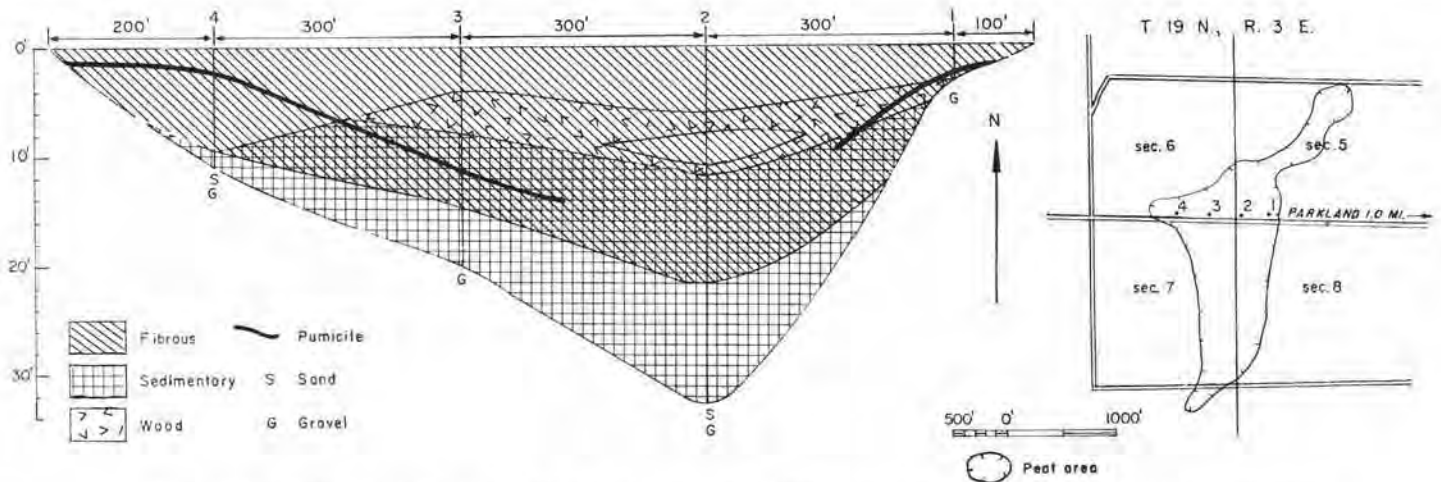

FIGURE 151.—Map and profile of Parkland peat area (38 acres). Map adapted from U. S. Department of Agriculture soil map of Pierce County.



FIGURE 152.—Peat dredge on float, Parkland peat deposit.

olive brown. The color of the mixture of fibrous peat and woody peat is similar to that of the fibrous peat.

The pumicite found in holes 1, 3, and 4 is white, and the layer is 1 inch thick. Pumicite was not found in hole 2, but it was probably dispersed in the peat there so that it was not recognized in the field observation. The deposit rests on gravel and sand.

In 1951 and for several years prior to that time, peat was being removed from this deposit and marketed by I. H. Seldon and M. A. Hartley of Tacoma.

Halverson peat area

Halverson peat area (31 acres) is in sec. 13, T. 16 N., R. 3 E., about 5 miles west of Eatonville. It lies in a depression in glacial drift. It is mapped on the soil map of Pierce County (Anderson et al., 1955) as Semiahmoo muck. It is utilized for pasture and hay. In addition to grasses and clover, some hardhack, knotweed, plantain, and buttercup grow in places.

In the central part of the area the peat is 25½ feet deep (fig. 153). The layer of fibrous peat at the surface is brown to dark brown and is disintegrated to decomposed. Its acidity (pH 5.0) is on the borderline between strongly

acidic and weakly acidic. The sedimentary peat varies in color from olive to olive green. It is weakly acidic (pH 5.5). The mixture of fibrous peat and sedimentary peat is olive brown. Its pH at the 7-foot depth is the same as that of the fibrous peat. White pumicite forms a layer

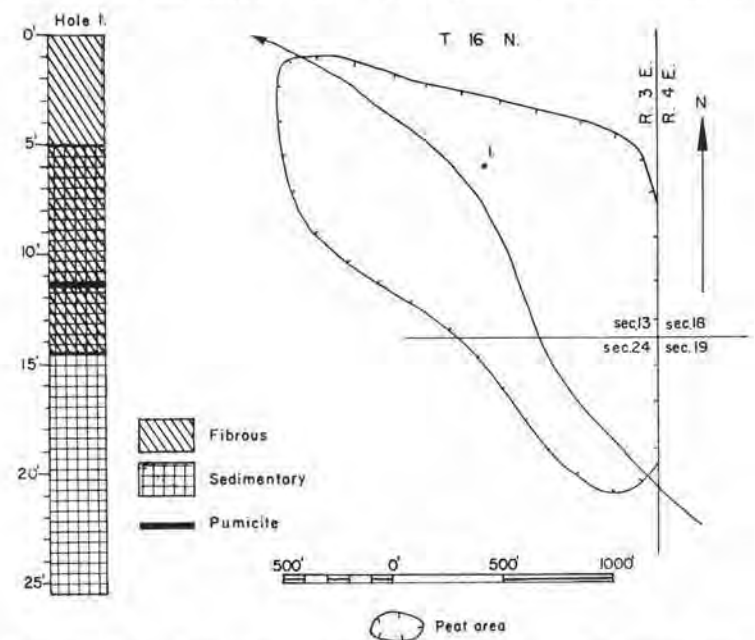

FIGURE 153.—Map and graphic log of a hole in Halverson peat area (31 acres). Map adapted from U. S. Department of Agriculture soil map of Pierce County.

1 inch thick in the mixed fibrous and sedimentary peat. The deposit rests on 8 inches of soft blue clay, which lies on sand.

Fircrest peat area

The Fircrest peat area (29 acres) is in the SE¼ sec. 2, T. 20 N., R. 2 E., within the city limits of Tacoma between Shirley and Bennett Streets and extending from South 15th Street to South 19th Street, which is the north city limit of the town of Fircrest. The area is shown as Mukilteo peat on the soil map of Pierce County (Ander-

son et al., 1955), which also shows at least four other small sedge peat areas as well as a much larger area of deep woody peat within 2 miles of the Fircrest deposit. All these peat areas occupy undrained or poorly drained low places between long ridges of Vashon glacial till. These ridges are elongated north-south, apparently parallel to the direction of movement of the Vashon ice sheet.

No streams flow into or out of the Fircrest bog. During the winter months water covers the bog to a depth of a few feet, but it is easily removed by pumping into the storm sewers of Fircrest. A dense growth of hardhack brush about 3 feet tall covers the peat, but at one time, probably prior to 1900, the area was utilized for truck gardening, according to local reports. Since 1946 bulk peat has been dug from the bog and sold by the truckload by W. Sanborn, 312 South Tacoma Avenue, Tacoma. Peat has been removed to a depth of 4 or 5 feet from an area of about 2 acres. On the west the peat was comparatively shallow and has been completely removed, exposing thin-bedded gray clay at the bottom, but on the east side of the excavation the peat is deeper, and a considerable amount of good fibrous peat remains below the floor of the pit.

The side of the excavation and a hole bored from the pit floor about 50 feet from the east margin of the peat area showed peat to a depth of 12 feet, all of which was fibrous and disintegrated or decomposed except for 1 foot of sedimentary peat at the bottom. The shallower peat is entirely fibrous. At the test hole a 2-inch layer of brown pumicite was present at a depth of 3½ feet.

McChord Airfield peat area

The McChord Airfield peat area (22 acres) is in sec. 1, T. 19 N., R. 2 E., and sec. 6, T. 19 N., R. 3 E., about 3 miles south of Tacoma just north of McChord Airfield. The road (Union Avenue) which connects U. S. Highway 99 with the north side of the airfield crosses the peat (map, fig. 154). The peat lies in a shallow depression in glacial

drift, and it is mapped as Rifle peat on the soil map of Pierce County (Anderson et al., 1955). The trees growing west of the road are cottonwood, willow, ash, and dogwood.

So far as revealed by the two holes which were bored, the upper 2 feet of this deposit consists of brown disintegrated fibrous peat, and the lower 2 feet in hole 2 is the same (fig. 154). In hole 2 a brown mixture of fibrous peat and diatomite extends from the 2-foot to the 6-foot level. The pumicite in both holes is brown and forms a layer 1 inch to 1½ inches thick. The deposit rests on gravel.

This peat area was largely destroyed in the course of highway construction in 1957.

Crescent Lake peat area No. 1

The Crescent Lake peat area No. 1 (10 acres) is in secs. 17 and 20, T. 22 N., R. 2 E., about 4 miles north of Gig Harbor. It borders the south and southeast shores of the lake (map, fig. 155). The lake and the peat are in a depression in glacial drift. Drainage is to the south to Gig Harbor. This is a sphagnum bog which has been modified somewhat by burning several years ago and also by lowering of the lake 2 or 3 feet by drainage.

In profile A, hole 1 is in a swampy zone 10 to 20 feet wide which has been exposed by the lowering of the lake. Its flora comprises sedge, purple marshlock, and *Dulichium*, with water lilies and water shield in the lake margin. Hole 2 is in the sphagnum bog which has been modified by burning. The plants growing there are Labrador tea, bog laurel, red huckleberry, salal, bracken fern, and cascara. The mosses growing on the surface are *Sphagnum* and *Hypnum*. Holes 3 and 4 are in a pure stand of bracken fern in an area which has been burned.

The sphagnum (fig. 155) is raw and varies from light brown to dark brown. Beneath this are complicated layers of fibrous peat, woody peat, muck, and sedimentary peat, with layers consisting of mixtures of these materials and some sand. The fibrous peat is brown to reddish brown to dark brown. It varies from soft to watery and from disintegrated to decomposed. The sedimentary peat is olive green, and the muck is black.

Profile B is in the sphagnum bog, where hemlock trees up to 8 inches in diameter are growing with salal and bog shrubs. The living moss here is mostly *Hypnum*. Hole 2 is in the same zone as hole 1 of Profile A. The properties of the materials in profile B are similar to those of the same materials in profile A. White and brown pumicite forms a layer 1 inch to 2 inches thick. The peat in hole 2 of profile A is strongly acidic. The pH of the sphagnum at the 1-foot depth is 3.7, and that of the sedimentary peat at 18 feet is 4.5. The deposit rests on gray sand and blue clay.

Crescent Lake peat area No. 2

Crescent Lake peat area No. 2 (1 acre) is in sec. 20, T. 22 N., R. 2 E., about 600 feet south of Crescent Lake peat area No. 1. It is covered with a dense growth of hardhack 5 to 6 feet tall. At the center of the area the peat is 6 feet deep. It consists of 1 foot of roots and leaves, 3 feet of reddish-brown to dark-brown fibrous peat,

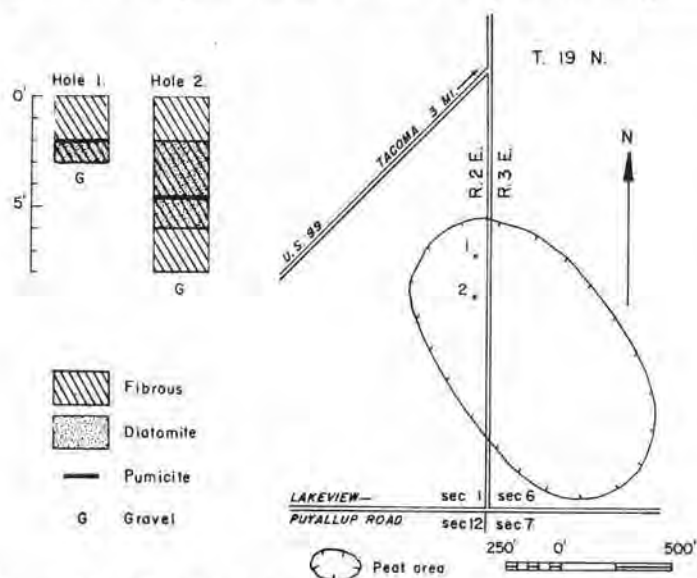

FIGURE 154.—Map and graphic logs of two holes in McChord Airfield peat area (22 acres). Map adapted from U. S. Department of Agriculture soil map of Pierce County.

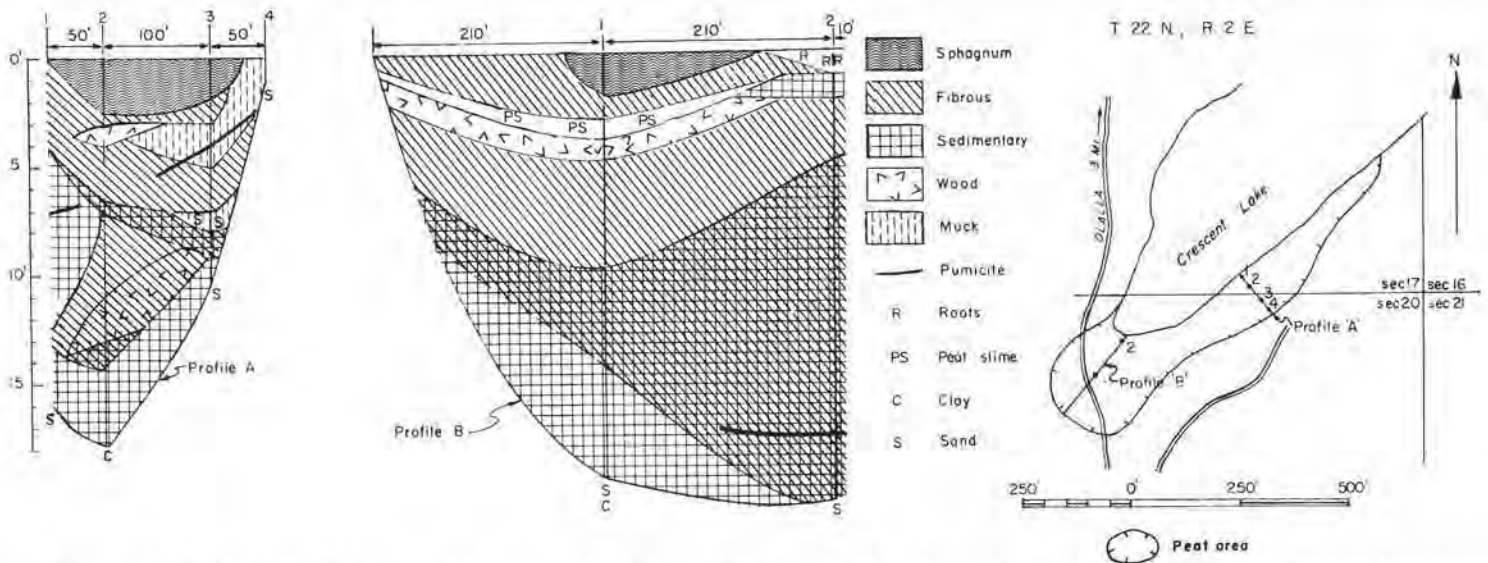

FIGURE 155.—Map and profiles of Crescent Lake peat area No. 1 (10 acres). Map adapted from U. S. Army Map Service photomosaic.

mostly decomposed, and 2 feet of light-brown watery muck grading into an olive-green mixture of clay and sedimentary peat at the bottom.

Bonney Lake peat area

Bonney Lake peat area (9 acres) is in sec. 29, T. 20 N., R. 5 E. (map, fig. 156), about ½ mile north of Bonney Lake and about 2 miles east of Sumner. The peat lies in a small stream valley cut in glacial drift. It is shown as Greenwood peat on the soil map of Pierce County (Anderson et al., 1955).

This peat is covered by a bog forest. The trees are mainly hemlock and lodgepole pine, some of which are as much as 30 feet or more in height. The surface of the peat is covered by a vigorous growth of *Sphagnum* and *Hypnum* in the spaces between the trees. In most places the two mosses grow separately and, where the two border, the *Sphagnum* is advancing on the *Hypnum*. The surface of the bog is sloping, and a small creek provides some drainage.

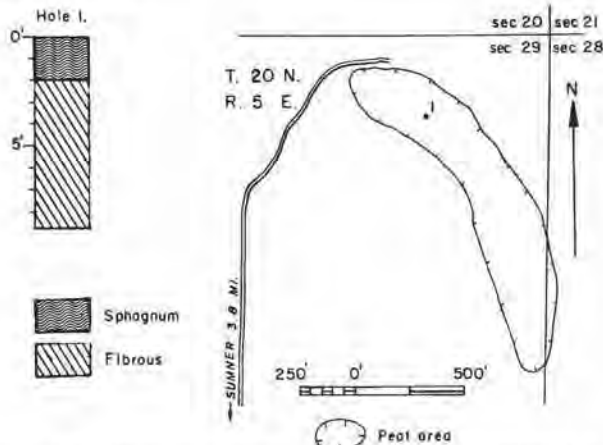

FIGURE 156.—Map and graphic log of a hole in Bonney Lake peat area (9 acres). Map adapted from U. S. Army Map Service photomosaic.

One hole near the center of the area (fig. 156), reveals 2 feet of raw brown sphagnum peat, below which is a layer of brown fibrous peat 6½ feet thick which varies from disintegrated to decomposed. The peat rests on gray sand. The sphagnum is of good quality, and its vigorous growth suggests that if the area is left undisturbed a large amount of sphagnum will accumulate with the passage of the years. This is a good place to experiment with the production of sphagnum.

Kirsten peat area

The Kirsten peat area (9 acres) is in sec. 23, T. 17 N., R. 2 E. (map, fig. 157), about 1½ miles east of McKenna.

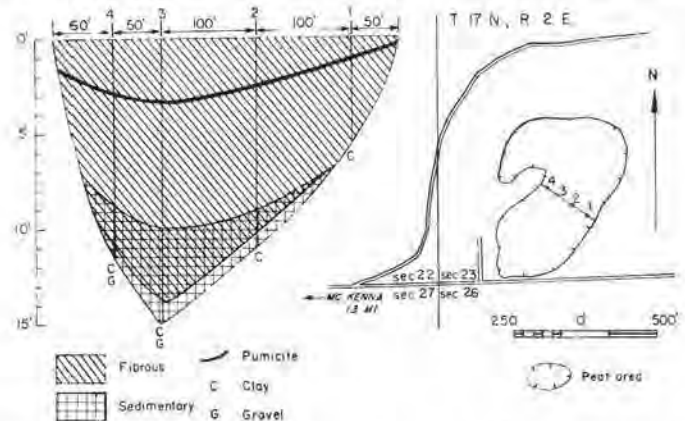

FIGURE 157.—Map and profile of Kirsten peat area (9 acres). Map adapted from U. S. Army Map Service photomosaic.

The peat lies in a depression in glacial drift, and it is shown as Dupont muck on the soil map of Pierce County (Anderson et al., 1955).

It is covered mostly with hardhack and sedge. The deposit (fig. 157) consists largely of fibrous peat which is brown to dark brown and disintegrated to decomposed. The thin layer of sedimentary peat at the bottom is olive and the mixture of fibrous peat and sedimentary peat is

brown. The layer of tan-colored pumicite is half an inch thick. The deposit rests on a thin layer of clay which varies in color from dark gray to blue and has sand and gravel under it.

Some peat was removed from this bog and marketed in bulk a few years ago by Kirsten Brothers.

Lake Tapps peat area

The Lake Tapps peat area (9 acres) is in sec. 8, T. 20 N., R. 5 E. (map, fig. 158), near the outlet from the lake, which is the intake for the Dieringer power plant. The deposit is about 3 miles northeast of Sumner. A power line crosses it. The peat is shown as Semiahmoo muck over Mukilteo peat on the soil map of Pierce County (Anderson et al., 1955).

The vegetation on the peat is composed of hardhack and goldenrod. One hole (fig. 158) at the center of the area reveals 2 feet 10 inches of brown disintegrated fibrous peat and 2 inches of olive sedimentary peat with gravel under it.

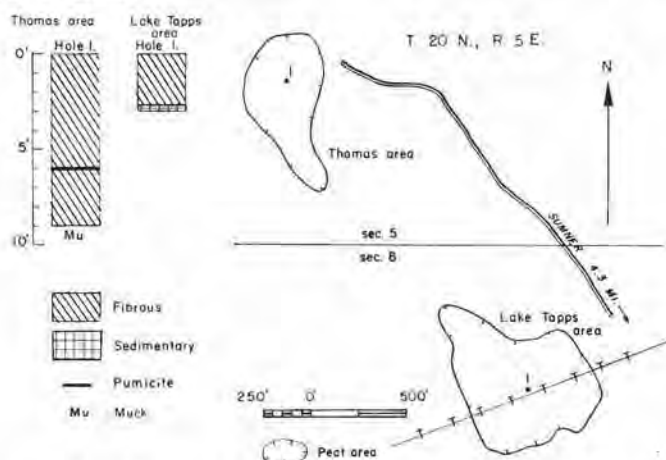

FIGURE 158.—Map and graphic logs of two holes in Lake Tapps and Thomas peat areas (9 acres and 5 acres). Map adapted from U. S. Department of Agriculture soil map of Pierce County.

Thomas peat area

The Thomas peat area (5 acres) is in sec. 5, T. 20 N., R. 5 E., about 900 feet northwest of the Lake Tapps peat area. It is shown as Mukilteo peat on the soil map of Pierce County (Anderson et al., 1955).

It has been cleared of vegetation, and in 1950 peat was being removed and marketed in bulk. The deposit (fig. 158) consists of 9 feet of fibrous peat which is brown to dark brown and disintegrated to decomposed. It rests on muck. The layer of brown pumicite is 1 inch thick.

Stevens Road peat area

Stevens Road peat area (4 acres, estimated) is in secs. 3 and 10, T. 20 N., R. 4 E., about 3½ miles northeast of Puyallup. Stevens Road crosses the western part of the peat area, which lies in a depression in glacial drift.

Sedge, which is the most abundant plant on the peat, is mostly dead. Living duckweed was common on wet soil in August 1950. This occurrence indicates that the area is flooded during the rainy season.

This deposit consists of 4½ feet of brown to dark-brown decomposed fibrous peat. The layer of brown

pumicite at the 3-foot depth is 1½ inches thick. The deposit rests on gray clay.

Tidal muck

A considerable area (80 acres, estimated) bordering the north side of the Nisqually River near its mouth is mapped as tidal muck (Tacoma muck) on the soil map of Pierce County (Anderson et al., 1955). It lies in secs. 32 and 33, T. 19 N., R. 1 E., and secs. 4 and 5, T. 18 N., R. 1 E., about 4 miles west of Fort Lewis.

Another, much larger, area (1,500 acres, estimated) of tidal muck is shown at the mouth of the Puyallup River, lying between East 11th Street on the northwest and U. S. Highway 99 on the south. This area is partly within the city limits of Tacoma.

These areas have not been investigated by workers in the survey of the peat resources of Washington.

Sphagnum in Mount Rainier National Park

Sphagnum occurs in several places at high elevations in Mount Rainier National Park. In Berkeley Park and at Mystic Lake it has formed a thin layer (8 inches) of peat which rests on sedge peat and muck. The *Sphagnum* occurs in patches 5 to 15 feet in diameter on swampy sedge meadows, and it is encroaching on the meadows. Some of the patches are flat, but in others the *Sphagnum* has formed low hummocks. The species identified are *S. teres* and *S. robustum*.

Three species of bog plants occur where *Sphagnum* is dominant, but not in the adjoining wet sedge meadows. They are small species of bog laurel (*Kalmia microphylla*), crowberry, and lodgepole pine. All these species also occur on drier places at high elevations on the mountain.

The elevation of the meadow in which *Sphagnum* occurs in Berkeley Park is approximately 5,700 feet, and of that bordering Mystic Lake is approximately 5,300 feet. Both are on the north side of Mount Rainier. They are very wet and receive comparatively little direct sunlight. The area within which the patches of *Sphagnum* occur in Berkeley Park is about 2 acres, and the area at Mystic Lake is a little larger. The patches of *Sphagnum* in these meadows represent early stages in bog development, and the indications are that with the passage of years they will increase in size and the layer of sphagnum peat will become thicker.

Similar patches of *Sphagnum* also occur in Mountain Meadows on the old Grindstone trail between Mowich Lake and Grindstone and also at Windy Gap (elevation 5,700 feet). *Sphagnum* also occurs at Lake James, Mowich Lake, and Eunice Lake. At these places it grows on soil, logs, and stumps, and does not form bogs. It is quite possible that *Sphagnum* may be found in the park at other places which have not been investigated.

SAN JUAN COUNTY DEPOSITS

GENERAL STATEMENT

San Juan County consists entirely of islands, which vary in size from Orcas Island (area 57 square miles) down to small rocks (map, fig. 159). The peat deposits in the county are of two kinds—fresh-water peat and salt-

water peat. The thirteen fresh-water deposits occur on San Juan, Lopez, Orcas, and Blakely Islands. Eight of these are sphagnum bogs, and thus have vegetation which is quite different from those in whose development *Sphagnum* has played little or no part. Six of them are on Orcas Island, one on San Juan Island, and one on Blakely Island. Four of the fresh-water bogs which are not sphagnum bogs are on San Juan Island. They include the largest and most important deposits. The other fresh-water, nonsphagnum bog is on Lopez Island. Thirty-five of the peat deposits of the county are in salt marshes and consist of salt-marsh peat. They are on San Juan, Henry, Lopez, Shaw, Blakely, Stuart, and McConnell Islands. The vegetation in them is, of course, quite different from that of the fresh-water peat areas.

The location of each peat area is shown on the map (fig. 159). Each area is numbered, and the number in parentheses after the name of each area in the description is its number on the map. Numbers 1 to 35 inclusive are salt marshes. Numbers 36 and 41 to 47 inclusive are sphagnum bogs, and numbers 37, 38, 39, 40, and 48 are fresh-water deposits which contain little or no sphagnum.

In the following discussion the fresh-water deposits are grouped under the names of the islands on which they occur, and the salt marshes are all grouped together under one heading. Some general information about the peat in the sphagnum bogs is, however, presented here because the available information applies to all eight of them situated on three islands, and details about the peat in the individual bogs are not available. An account of the development of sphagnum bogs in the San Juan Islands by Rigg and Richardson (1934) gives this information and also a profile of each bog. The profiles of the sphagnum bogs of San Juan County in the present bulletin are redrawn from these profiles.

The sphagnum designated as "1-4" is either raw or only moderately disintegrated, and that designated as "5-10" is more disintegrated, some of it completely so. Remains of some other mosses are present in small quantities with the sphagnum. The ones that have been identified are *Hylocomnium proliferum*, *H. triquetrum*, *Dicranum scoparium*, and *Bryum pallescens*.

The sedge peat consists mainly of the remains of sedges, but the remains of plants similar to sedges are present to a limited extent. There are also some remains of mosses other than *Sphagnum* and also some remains of woody stems and roots. The color of the sedge peat is mostly brown, but some of it is olive green. The mosses and wood are present in small fragments, and the woody roots are small.

The woody peat consists mostly of small fragments which are the result of partial decay, but there are some larger pieces of wood which are soft enough to be penetrated with the peat borer.

The material which in these profiles is called lake mud contains much organic matter, and most of it would probably be called sedimentary peat if the same criteria had been applied as are used in describing peat in counties other than San Juan in the present bulletin. The pumicite is white. Many diatoms, some sponge spicules, and some remains of filamentous algae are present.

PEAT AREAS ON SAN JUAN ISLAND

Beaverton Valley peat area (37)

The Beaverton Valley peat area (240 acres) is in secs. 2, 3, 9, 10, and 11, T. 35 N., R. 3 W. (map, fig. 160), in the broad flat valley about 1 mile northwest of Friday Harbor. The wood-stave pipe which carries the water supply to Friday Harbor from Trout Lake lies on the surface of the peat. Formerly it was buried in the peat, but the wire with which the pipe was bound deteriorated, and repairs were difficult because of excess water in the peat, so the pipe was moved to the surface.

The eastern end of the peat is less than 1 mile from salt water, and its elevation is a little more than 100 feet above sea level. In about 1875 a drainage ditch was dug across the peat to the bay on which Friday Harbor is situated. P. N. Girard, of Friday Harbor, who has known the valley since about 1903 and has learned its earlier history from persons who knew it long before that date, has furnished information in regard to the ditch and former conditions in the valley. As long as the ditch was cleaned out and deepened from time to time it provided good drainage. In July 1953 it was much in need of cleaning and perhaps deepening. No water was flowing in it at that time, but there was shallow standing water in some places.

Most of the peat area is now in pasture, but there are some fields of oats used for hay, and Mr. Girard has a 5-acre garden at the south side of the peat bordering the road in the SE $\frac{1}{4}$ sec. 10. Tussocks of a reed (*Juncus*) and many weeds grow with the pasture grasses, and there is some evidence that they are increasing at the expense of the grasses. Reed canary grass is common. Overgrazing and lack of drainage have probably been the principal factors in such deterioration as has occurred in the pasture.

The production of hay and oats has not been regular. Fields were planted some years, and other years they lay idle. Some areas that produced good crops 40 years ago are now covered with brush 10 feet tall. The main crops grown in the garden are potatoes and mangels, but carrots, onions, cauliflower, and celery are also produced.

Great changes have occurred in the Beaverton Valley peat area during the 75 or more years that have passed since the clearing and draining were begun. A swamp forest formerly covered part of the area, and brush grew on part of it. The evidence for the swamp forest is the presence of old stumps in the banks of the drainage ditch and in the peat nearby, the presence of logs and pieces of rotten wood buried in the peat, and the presence of small particles of wood suspended in the peat slime. The evidence for the former existence of brushy areas is that some dense growths of brush are still in their native condition, and that brush quickly invades neglected areas. The history of the 5-acre garden area furnishes additional evidence. Before it was cleared in 1927 or 1928 it was a jungle of alder and willow with some pine. Long before that it was a forest of large spruce and cedar trees, but beavers dammed the lower end of the marsh, and the trees were killed by flooding.

The profile (1,755 feet long) extends slightly east of north from the southern border to the northern border

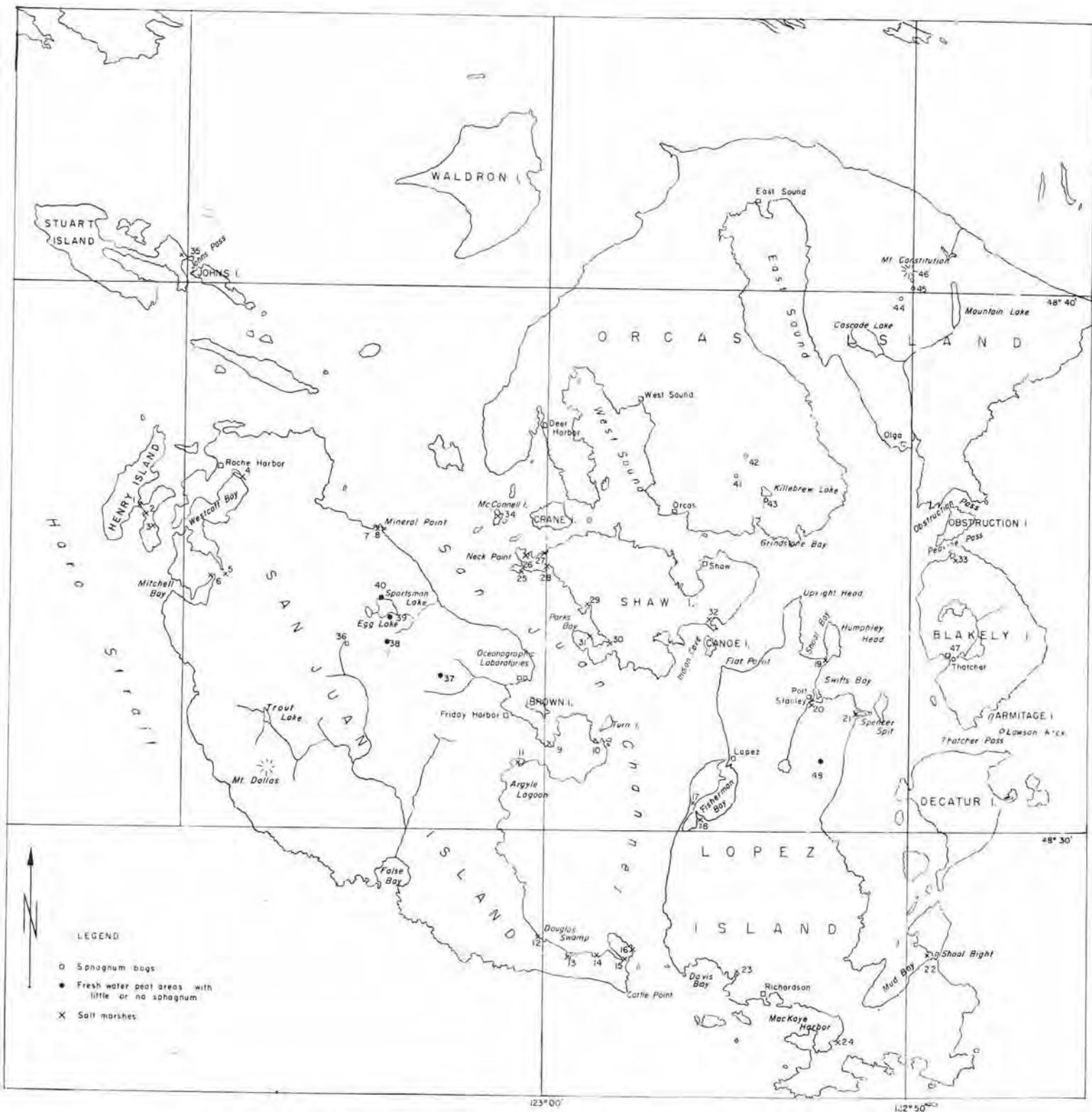

FIGURE 159.—Map of San Juan Islands showing locations of sphagnum bogs, fresh-water peat areas with little or no sphagnum, and salt marshes.

(map, fig. 160). Hole 1 is in Mr. Girard's garden 10 feet south of its northern border. Holes 2 and 3 are in pasture land where the most conspicuous vegetation is tussocks of rush (*Juncus*). Between these tussocks grow reed canary grass, silver weed, and pasture grasses. Hole 3 is 25 feet south of the drainage ditch. There are old stumps of small trees in the banks of the ditch and also in the nearby peat. Hole 4 is in pasture land where the vegetation consists of reed canary grass and pasture grasses. Hardhack grows along the line of the profile north of hole 4 near the margin of the area.

The profile (fig. 60) shows fibrous peat, woody peat, sedimentary peat, and mixtures of these, and also some peat slime. The fibrous peat is light brown to dark brown and is raw to disintegrated to decomposed. The sedimentary peat is mostly brown, but some of it is light brown, and in some places toward the bottom it is greenish-brown.

In water content it varies from moist at the top of the layer to wet and even watery at greater depth. At the bottom it is comparatively dry and is very compact. At the 43-foot depth in hole 2 it is too compact to be penetrated with the peat borer. Marsh gas (methane) is present at the 15- to 17-foot depth. At the 23- to 24-foot depth the peat contains small gastropod (snail) shells and fragments of pelecypod (mussel) shells, both of which were identified as fresh-water species by Paul L. Illg and Robert L. Fernald of the Zoology Department at the University of Washington. The woody peat consists mostly of particles of pea-size or even smaller, but occasionally the borer cut through pieces of rotten wood up to 1 inch thick. In one boring (hole 3) a log was encountered at the 1-foot depth. In this hole at the 2- to 3-foot depth small particles of wood are suspended in the peat slime. In hole 2 the peat is weakly acidic (pH 6.0)

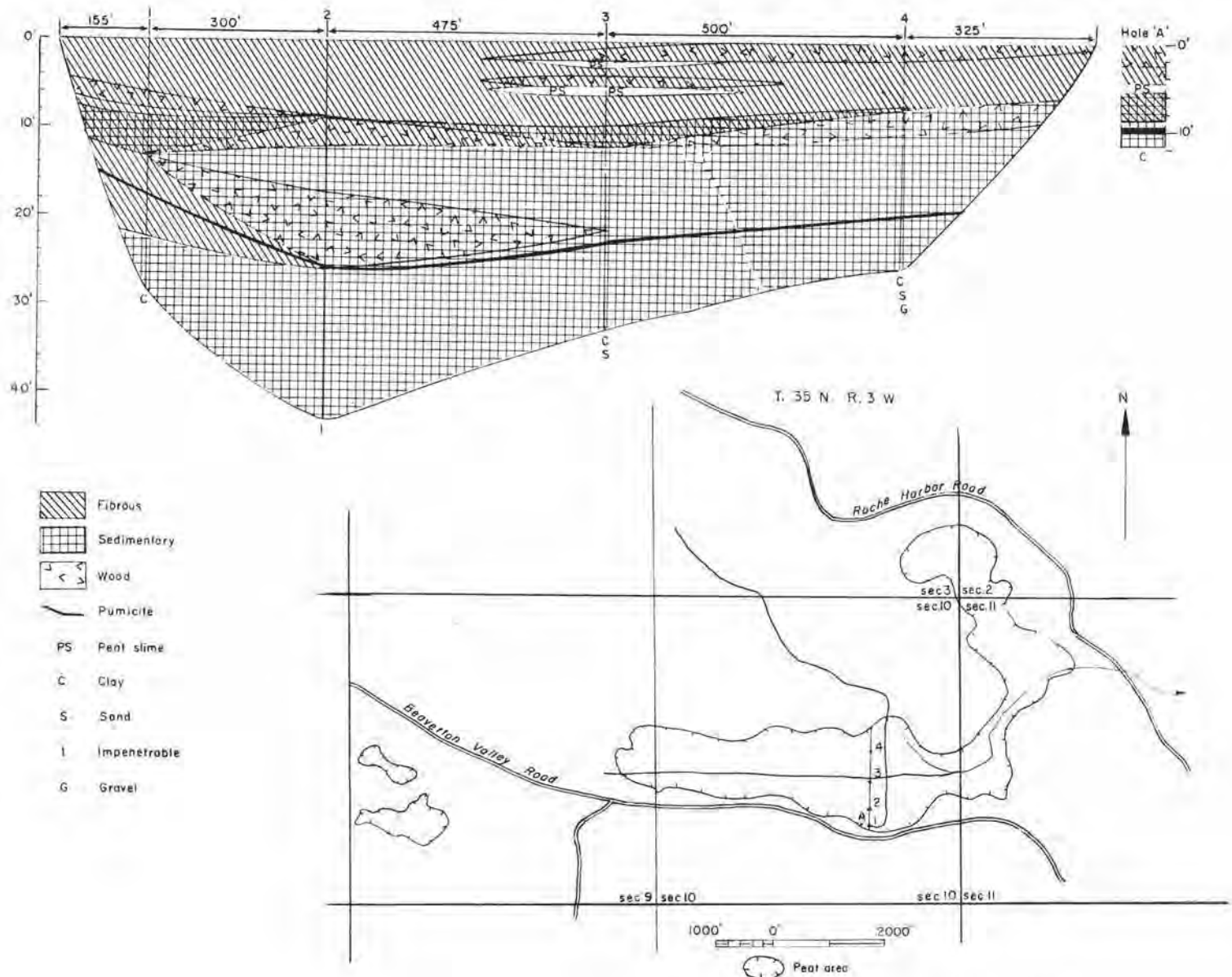

FIGURE 160.—Map, profile, and graphic log of a hole in Beaverton Valley peat area (240 acres). Map adapted from field sketch by John Sherman.

at the 6-foot depth and neutral (pH 7.0) at the 18-foot depth. The pumicite is white; it is mixed with the peat and does not form a definite layer. The mixture is about 2 inches thick in holes 2, 3, and 4, but is 4 inches thick in hole 1. The deposit rests on blue clay that is mixed with sand in hole 3 and sand and gravel in hole 4.

In about 1935 a single hole (fig. 160) was bored by Rigg in Mr. Girard's garden southwest of hole 1 of the profile. The materials found in it were similar to those in hole 1, but there was a 1-foot layer of peat slime and wood at the 4½- to 5½-foot depth, and the white pumicite formed a definite layer. Gastropod and pelecypod shells were present in this hole as they are in hole 1. This hole is only 11½ feet deep, but hole 1 is 28½ feet deep.

Two small peat or muck areas (5 and 14 acres) mapped by Dr. John Sherman west of the main area in the SW¼ sec. 9, south of the road, were not investigated.

Section 4 peat area (38)

The Section 4 peat area (40 acres) is in sec. 4, T. 35 N., R. 3 W., about 1 mile south of Sportsmans Lake (map, fig. 161). It is a short distance west of the Friday Harbor-Roche Harbor road. In 1953 most of the area was in oats, but a small part of the north arm still had the natural vegetation of hardhack, tussocks of rush, and some silver weed. There is a drainage ditch crossing the southern and eastern part of the area which in wet weather carries water to San Juan Channel.

The profile (1,300 feet long) extends in a northwesterly direction from the southern border of the area. Holes 2, 3, and 4 are in line, but hole 1 is east of the line. The distances from hole 1 to the southern border and from hole 4 to the northern border are estimated. The other distances, between holes, were paced.

Hole 1 is in the drainage ditch, and the upper 2-foot section of this hole as shown in the profile (fig. 161) represents the bank of the ditch. Hole 2 is in a slight natural depression which extends irregularly in a northerly direction across the peat. Hole 3 is in a small shallow oval depression (10 by 15 feet) which is too wet for crops. Hole 4 is in the area of natural vegetation.

The profile shows peat soil, muck, fibrous peat, woody peat, peat slime, and sedimentary peat. The muck is black. The characteristics of the other materials are not essentially different from those of the materials in the Beaverton Valley deposit. Gastropod and pelecypod shells similar to those found in the Beaverton Valley peat are present at the 8- to 11-foot depth in hole 4. The deposit rests on clay which is blue in holes 1, 2, and 4, but is gray in hole 3.

Four other small peat or muck areas (3, 4, 6, and 8 acres) mapped in sec. 4 by Dr. John Sherman were not investigated.

Sportsmans Lake peat area No. 1 (39)

The Sportsmans Lake peat area No. 1 (very roughly estimated as 35 acres) is in sec. 4, T. 35 N., R. 3 W., about 3 miles northwest of Friday Harbor. It borders the south shore of Sportsmans Lake. The field work on this peat was done in 1938 and preceding years. Considerable changes in the vegetation may have occurred since that time. At the time of the investigation the peat area comprised a pasture, a hayfield, some waste land, and a mat of vegetation bordering the lake. There are some rock outcrops in the peat, and much of the lake shore is rocky. A drainage ditch extends across the peat from the south shore of the lake. At the time of the investigation no water was flowing in the ditch, but some water was standing in it.

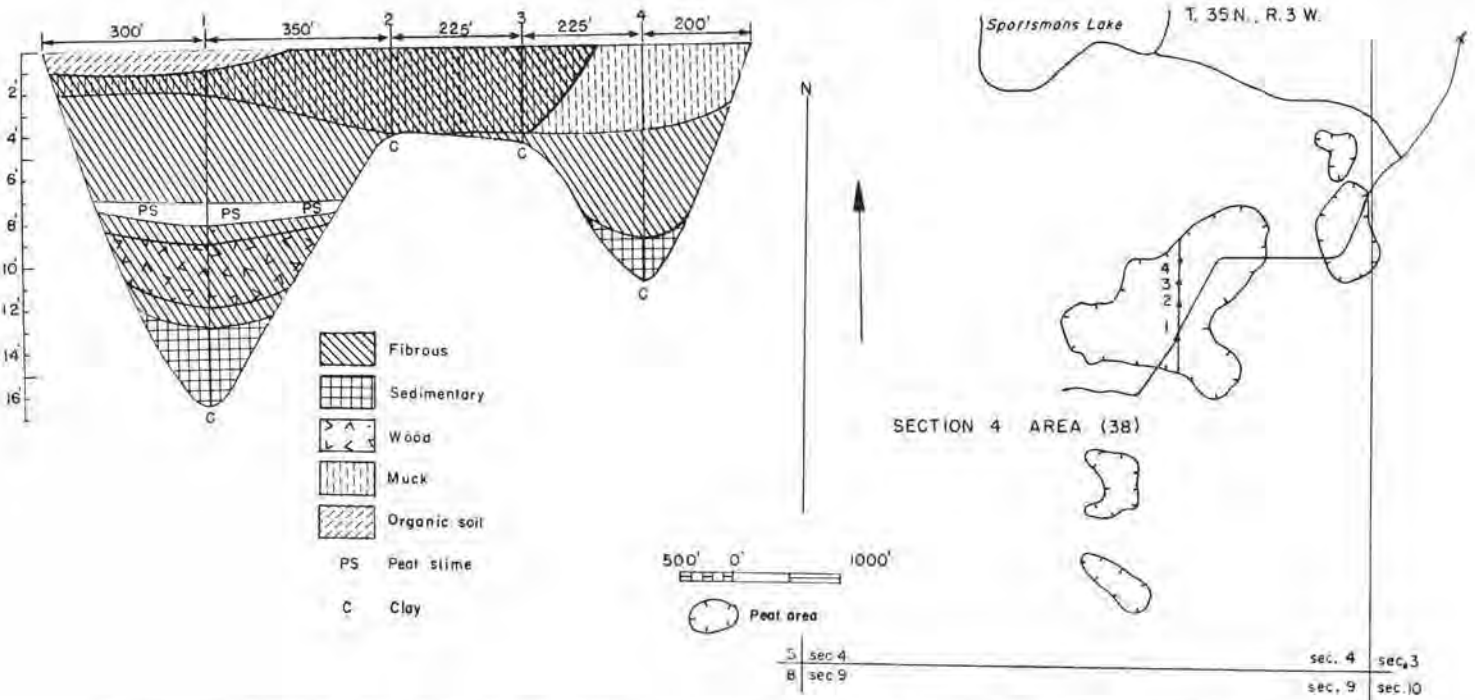

FIGURE 161.—Map and profile of Section 4 peat area (40 acres). Map adapted from field sketch by John Sherman.

The vegetation on the mat includes cattails, sedges, buckbean, purple marshlocks, water celery, water lily, mint, marestail, monkeyflower, bedstraw, several mosses, and young alder trees and willows. Some of the aquatic species extend into the lake.

The lake as measured by R. Lindeman is over 30 feet deep to rock bottom in some places, but there is a layer of very soft organic matter several feet deep over the rock bottom. The water of the lake is turbid and alkaline.

The vegetation on the peat south of the mat includes silver weed, knotweed, a rush, a violet, several common weeds of waste places, Labrador tea, hardhack, wild rose, and willows. Stonewort, marestail, and several filamentous algae are abundant in the ditch.

A hole bored in the mat where willows are numerous, about 750 feet south of the lake, shows 35½ feet of peat resting on soft blue clay which contains fragments of clam shells. These were identified by R. C. Miller as fragments of the shells of *Anadonta*, the genus of fresh-water clam which still lives in the lake. The mat at the place where the hole was bored is 3 feet thick and consists mainly of a very dense growth of roots. It is so firm that it does not sink when jumped on, and it is comparatively dry. Nearer the lake it is wet, and it sinks perceptibly under the weight of a man. Under the mat is a 3-foot layer of mixed fibrous and sedimentary peat. Below this the sedimentary peat is 29½ feet deep. It is brown to grayish brown and is very soft and watery. At some levels it is so watery that it approaches the characteristics of peat slime.

A second hole, which was bored in the margin of the hayfield about 600 feet southwest of the hole described above, shows 28½ feet of peat resting on blue clay. The mat is 3½ feet thick. It consists mainly of roots but has sod at the surface. A layer of peat slime under the mat is 3½ feet thick, and underlying this is 21½ feet of sedimentary peat. The sedimentary peat in this hole is similar to that in the first hole.

A third hole was bored in a part of the peat area which had been plowed 8 years earlier but was waste land and pasture at the time of the boring. It was not definitely located but is near some rock outcrops. In this hole a mat 3½ feet thick is underlain by 7 feet of sedimentary peat. The sod at the surface is firm, and the sedimentary peat is much drier than that in the other two holes.

Sportsmans Lake peat area No. 2 (40)

This is a very small mat of vegetation bordering the northwest shore of Sportsmans Lake. In 1927 small patches of *Sphagnum* were growing among the semi-aquatic plants on this mat. The mat is 2 feet thick and consists mostly of living roots. Under the mat is 18 feet of peat slime underlain by 6 feet of sedimentary peat. The characteristics of the peat slime and the sedimentary peat here are similar to those of the same materials found in area No. 1, south of the lake.

San Juan peat area (36)

The San Juan peat area (15 acres, including 5 acres of sphagnum) is in sec. 5, T. 35 N., R. 3 W., about 6 miles by road northwest of Friday Harbor. It is surrounded by low rock hills, most of which have a mantle of glacial drift on which there is open coniferous forest. The elevation of the peat is about 300 feet above sea level. The highest point on the island (Mount Dallas, 1,036 feet) is about 3 miles southwest of the peat.

During the rainy season a small stream provides some drainage from the peat, flowing through a narrow break in the hills and into False Bay. Efforts to drain the area by deepening the channel of this creek at the margin of the peat have resulted in only superficial drainage, because rock was encountered. This drainage and the burning of as much of the vegetation as possible have practically destroyed the sphagnum bog and have modified the surrounding wet area so that it is now used for pasture. The profile of the peat is shown in figure 162.

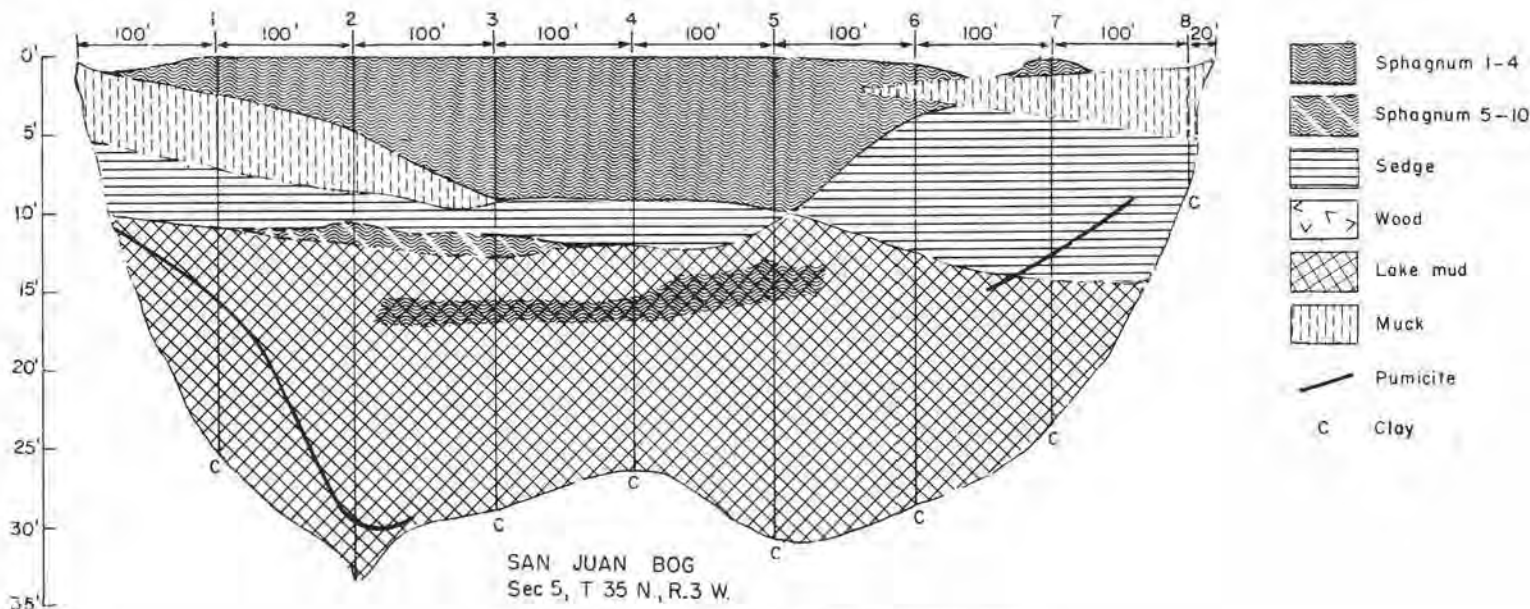

FIGURE 162.—Peat profile in San Juan peat area.

Soil temperatures in the sphagnum area at a depth of 6 inches and air temperatures at a height of 4 feet have been determined by Rigg (1947). Continuous soil and air thermograph records for the year 1941 give the following information.

The general course of maximum and minimum soil and air temperatures is upward from January to July 21 and then downward to the end of the year. Maximum air temperatures over the sphagnum are comparable to those in Friday Harbor, but minimum air temperatures are much lower than those in the town. Freezing temperatures of the air over the peat occurred during every month of the growing season (April to September inclusive) except August, when the minimum was 34° F. The minimum for both April and May was 24° F. and for both June and July, 28° F. Changes in air temperature from day to night during the growing season were large compared with the small changes which occurred in the soil during the same periods. The minimum soil temperature did not go below 46° F. during the growing season, and the maximum did not go above 68° F.

Air temperatures over many peat areas are lower than those over neighboring hard land. Peat areas are commonly at a lower level than the surrounding hard land, and cold air therefore drains onto the peat. Other factors also operate to produce low air temperatures over peat, especially in sphagnum bogs. Careful consideration of soil and air temperatures in peat areas is desirable before attempting to grow on them any crops which are especially sensitive to low temperatures. The facts stated in this bulletin (p. 122, 124) in regard to temperatures in the commercial cranberry marshes of Pacific County furnish support for this caution.

Other peat areas on San Juan Island

There are some peat areas in valleys and depressions in the western and southwestern parts of the island, but their extent and the depths and character of the peat in them have not been investigated.

PEAT AREA ON LOPEZ ISLAND

Spencer peat area (48)

The Spencer peat area (90 acres) is in secs. 13 and 24,

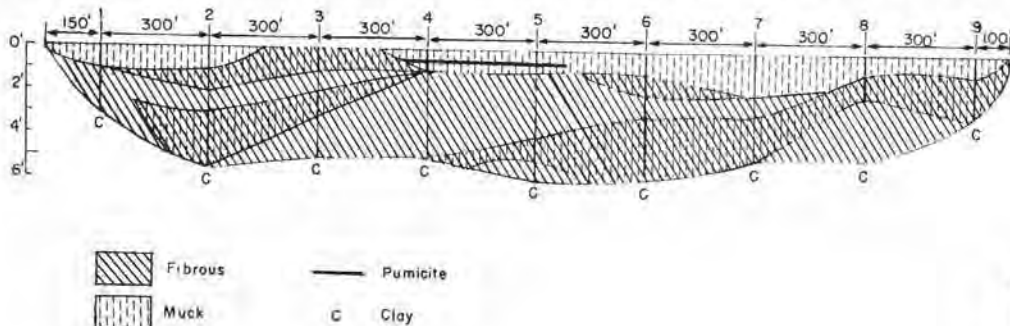

T. 35 N., R. 2 W. (map, fig. 163), about 2 miles east of Lopez and about 1 mile south of Port Stanley.

It occupies a depression in a glaciofluvial deposit. Its elevation is 85 feet above sea level, and it is surrounded, except on the east side, by low rounded hills. It is drained by a ditch to Lopez Sound, which is about a quarter of a mile east of its eastern border. The extent of drainage is controlled by opening or closing an earth dam in the ditch at the border of the peat. Water is held on the peat during the winter and allowed to flow out in the spring. In May 1953 the dam was open, but no water was flowing, and most of the surface of the peat was free from water. However, water stood 6 inches deep in some places and 3 feet deep in a depression where the peat was burned away many years ago.

The peat is on the farm owned and operated by Roscoe D. Spencer and his sons, James O. Spencer and Walter Spencer. Mr. Spencer has known the area for many years. He states that a long time ago the peat and some of the flat land surrounding it was a beaver dam lake and that after the removal of the beaver dam the area was covered with brush for some years, but was later completely cleared.

The entire area is used for pasture. The pasture grasses are mainly bent grass and reed canary grass, but some quack grass growth with them. An acid-tolerant strain of lotus has been planted, and the small plants are common in a few places. In the wetter places sedges, reeds (*Juncus*), knotweed, dock, and buttercup are common. Hardhack and willows grow along the ditch and on the borders of the depression where peat was burned. A crop of oats was grown on the peat in 1951. The crop yielded oats of good quality, but it grew tall and lodged so that it was difficult to harvest. Since that year the area has been used for pasture only.

The profile (2,650 feet long) extends from north to south. The deposit (fig. 163) consists of fibrous peat, muck, mixtures of the two, and mixtures of fibrous peat with small leaves of woody plants. The fibrous peat is brown to dark brown and is raw to disintegrated to decomposed. It varies from moist to wet to watery. The muck varies from black to dark brown. The leaves mixed with the

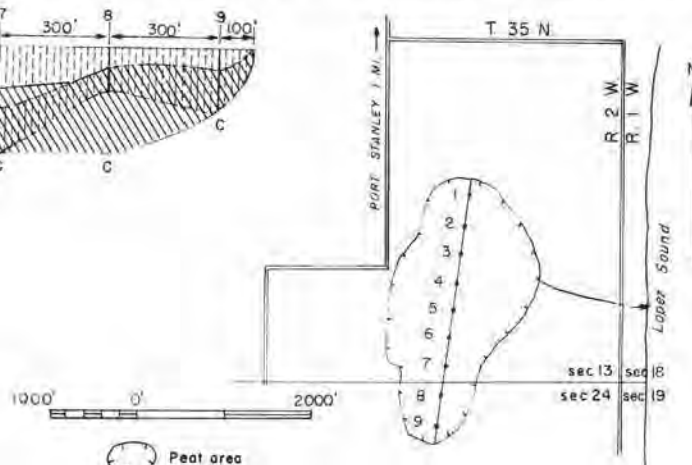

FIGURE 163.—Map and profile of Spencer peat area (90 acres). Map adapted from U. S. Soil Conservation Service soil map.

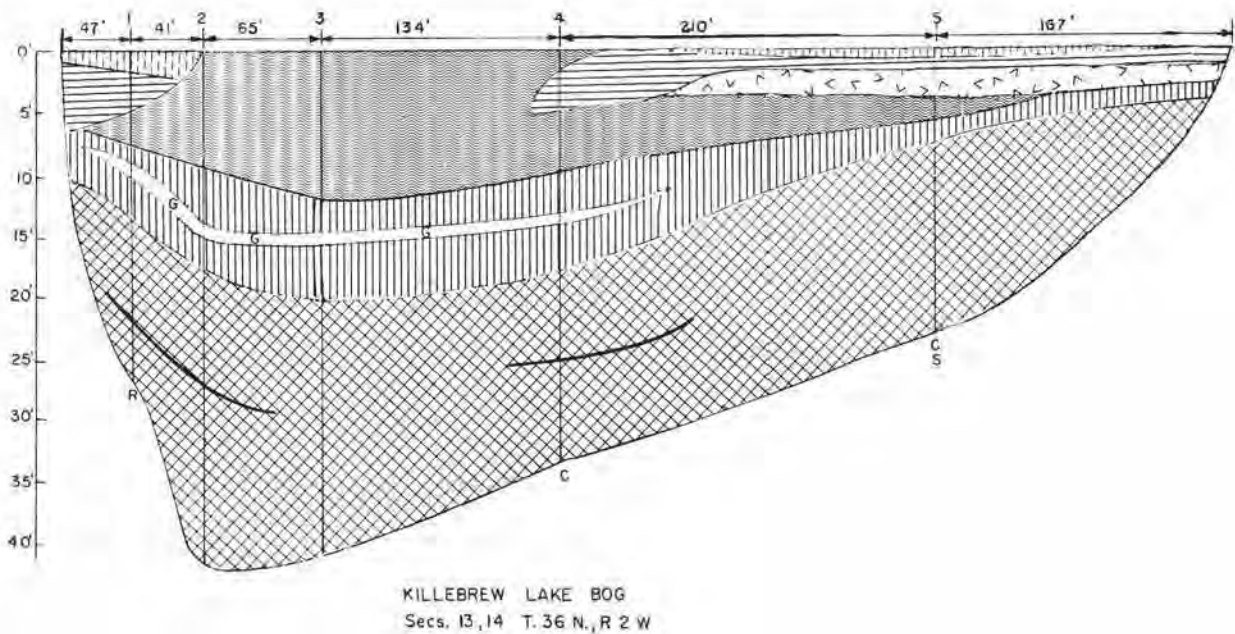
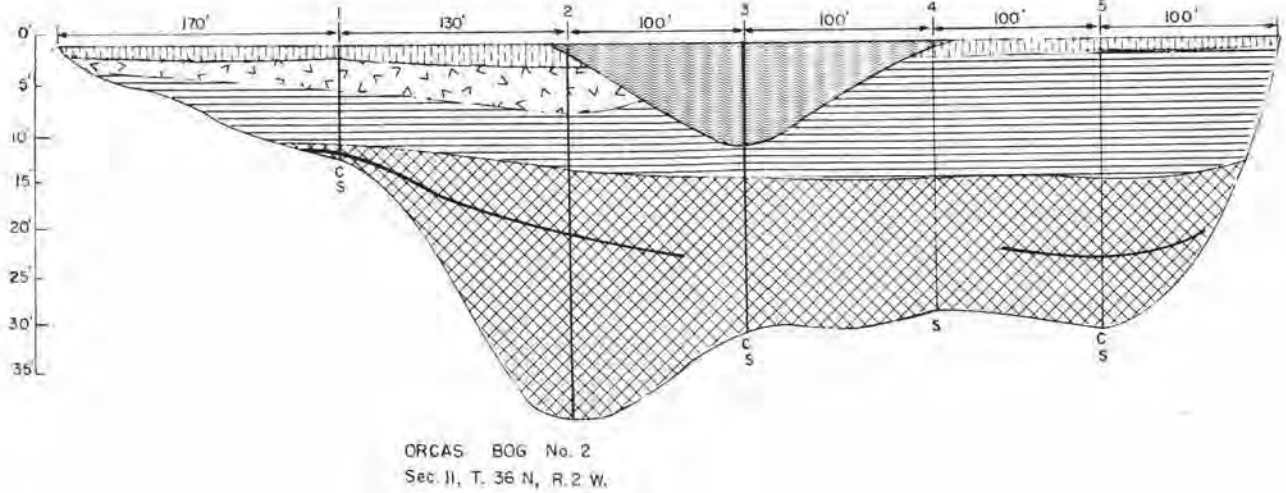
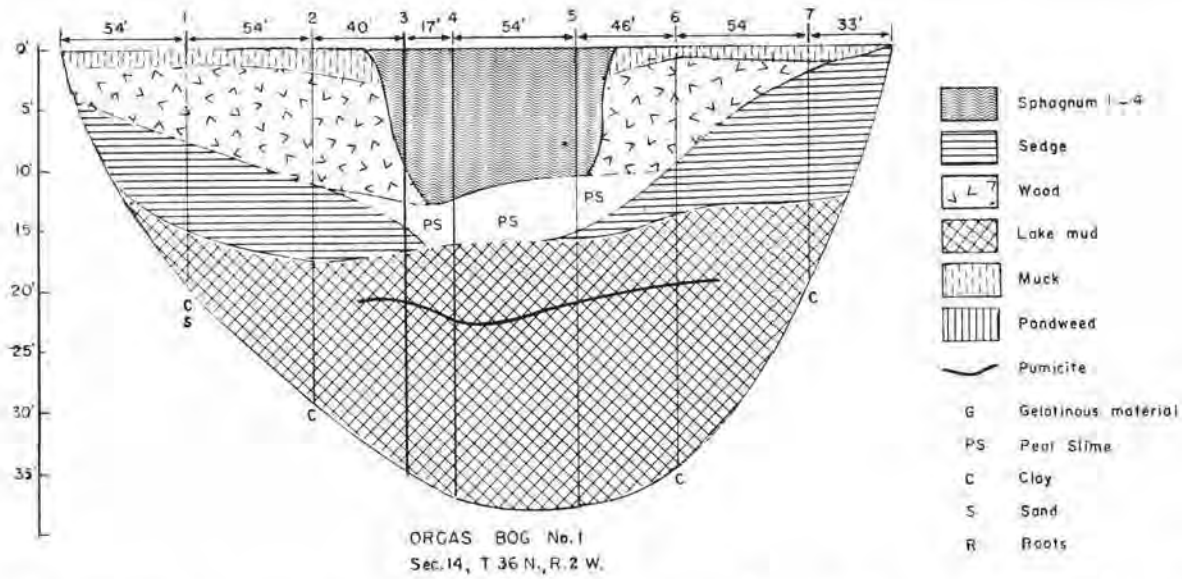

FIGURE 164.—Peat profiles in Orcas peat area No. 1, Orcas peat area No. 2, and Killebrew Lake peat areas.

fibrous peat show very little disintegration. The peat is rather weakly acidic (pH 5.0). The water in the drainage ditch at the dam is very weakly acidic (pH 6.5). Grayish-white pumicite 1 inch thick is mixed with the muck at the 1-foot depth in holes 4 and 5. Rust-brown pumicite is abundant at the 1- to 2-foot depth in the banks of the ditch at the dam. Many sponge spicules and a few diatoms occur with it. On the profile line the deposit rests on blue clay.

PEAT AREAS ON ORCAS ISLAND

The six peat areas on Orcas Island are all sphagnum bogs, some of which have sedge meadows or swamps adjoining them. The various kinds of materials found in them have been described (p. 152).

Orcas peat area No. 1 (41)

Orcas peat area No. 1 (about 9 acres) is in sec. 14, T. 36 N., R. 2 W., about 2 miles northeast of the town of Orcas. It is circular in shape and is surrounded by steep rock slopes which rise northeastward to a range of low mountains 1,100 feet high. A profile of the peat is shown in figure 164.

Orcas peat area No. 2 (42)

Orcas peat area No. 2 (about 18 acres) is in sec. 11, T. 36 N., R. 2 W., near Orcas No. 1. It is surrounded by steep rock slopes. A profile is shown in figure 164.

Killebrew Lake peat area (43)

Killebrew Lake peat area (about 30 acres, of which about 4 acres is sphagnum) is in sec. 14 (possibly also in sec. 13), T. 36 N., R. 2 W., about $\frac{3}{4}$ mile north of Grindstone Bay and about $2\frac{1}{2}$ miles by road northeast of the town of Orcas. It is surrounded on three sides by rocky hills and on the fourth side by a marsh and the southwest shore of the lake. A profile of the sphagnum area is shown in figure 164.

Hansen (1943b, 1947) made a study of the pollen in the peat of this bog. At the place where he bored, the peat was 9.5 meters (31 feet 2 inches) deep, and pumicite was found at a depth of 7 meters (22 feet 11 inches). There were 3.25 meters (10 feet 8 inches) of fibrous peat, 5.5 meters (18 feet) of limnic (sedimentary) peat, 0.5 meter (1 foot 8 inches) of silt, and 0.5 meter of sand.

Constitution peat area No. 1 (45)

Constitution peat area No. 1 (about 9 acres) is in Moran State Park and is less than half a mile north of Cold Spring bog. It is at an elevation of 2,050 feet and is surrounded by rock banks but has some drainage through a channel to the east. The peat lies in the NE $\frac{1}{4}$ NE $\frac{1}{4}$ sec. 29 and the NW $\frac{1}{4}$ NW $\frac{1}{4}$ sec. 28, T. 37 N., R. 1 W. It is partly sphagnum bog and partly sedge meadow. A profile is shown in figure 165.

Constitution peat area No. 2 (46)

Constitution peat area No. 2 (less than 5 acres) is in Moran State Park near the summit of Mount Constitution, the elevation of which is 2,409 feet above sea level. It is in the SE $\frac{1}{4}$ SE $\frac{1}{4}$ sec. 20 and the SW $\frac{1}{4}$ SW $\frac{1}{4}$ sec. 21, T. 37 N., R. 1 W. It is in the north end of the depression in

which Constitution peat area No. 1 lies, and may be more or less continuous with it. Area No. 2 is a sphagnum bog with some sedge meadow bordering it. In the bog is a pond in which there is a small bog island.

There is a dense growth of stonewort (*Chara*) in the pond. The occurrence of stonewort in a sphagnum bog pond is very unusual in the state of Washington. The water of the pond as determined by F. W. Gail, Botany Department, University of Idaho, is weakly acidic (pH 6.2). Deposits of marl are commonly found in lakes in eastern Washington in which stonewort occurs, and occasionally in western Washington, but no marl was found in the profile (fig. 165) of the Constitution peat area.

Hansen (1943, 1947) found 9.0 meters (29 feet 6 inches) of materials in his sedimentary column in the Mount Constitution peat deposit (probably Constitution No. 2). This includes 3.25 meters (10 feet 8 inches) of fibrous peat, 5.25 meters (17 feet 4 inches) of limnic (sedimentary) peat, and 0.5 meter (1 foot 8 inches) of clay. He found volcanic ash (pumicite) at a depth of 7.75 meters (25 feet 5 inches). The total depth of the peat and the position of the pumicite in this deposit are similar to those that he found in the Killebrew Lake deposit.

Cold Spring peat area (44)

The Cold Spring peat area (about 7 acres) is in Moran State Park, near the center of the E $\frac{1}{2}$ sec. 29, T. 37 N., R. 1 W., about 4 miles southeast of the town of East Sound. The road to the summit of Mount Constitution passes near the area. Its elevation is about 2,000 feet above sea level and only about 400 feet below the summit of Mount Constitution, the highest point in the San Juan Islands. It is surrounded by rocky banks 10 to 20 feet high, except at the southeast side, where there is some drainage. There is very little flow from the spring. A profile is shown in figure 165.

PEAT AREA ON BLAKELY ISLAND

Blakely peat area (47)

The Blakely peat area (elevation about 300 feet) is in sec. 3, T. 35 N., R. 1 W., some distance southwest of Spencer Lake and about three quarters of a mile from Thatcher Post Office, which is on the shore of a small bay on the west side of the island. The deposit consists of a sphagnum bog 125 by 50 feet bordered on the east by rock and on the other sides by a small swamp whose area has not been determined. A profile of the sphagnum bog is shown in figure 166. The peat in the swamp has not been investigated. The swamp has been used as a hog wallow, but the sphagnum bog is still in its natural state.

SALT-MARSH PEAT AREAS

Shallow salt-marsh peat is present in at least 35 salt marshes on several islands. No exact determinations of the areas have been made, but they vary from perhaps 20 acres or more down to mere patches only about 100 feet in diameter. The locations of 35 salt marshes are shown on the map (fig. 159). They are numbered 1 to 35 and will be referred to by number in the following discussion.

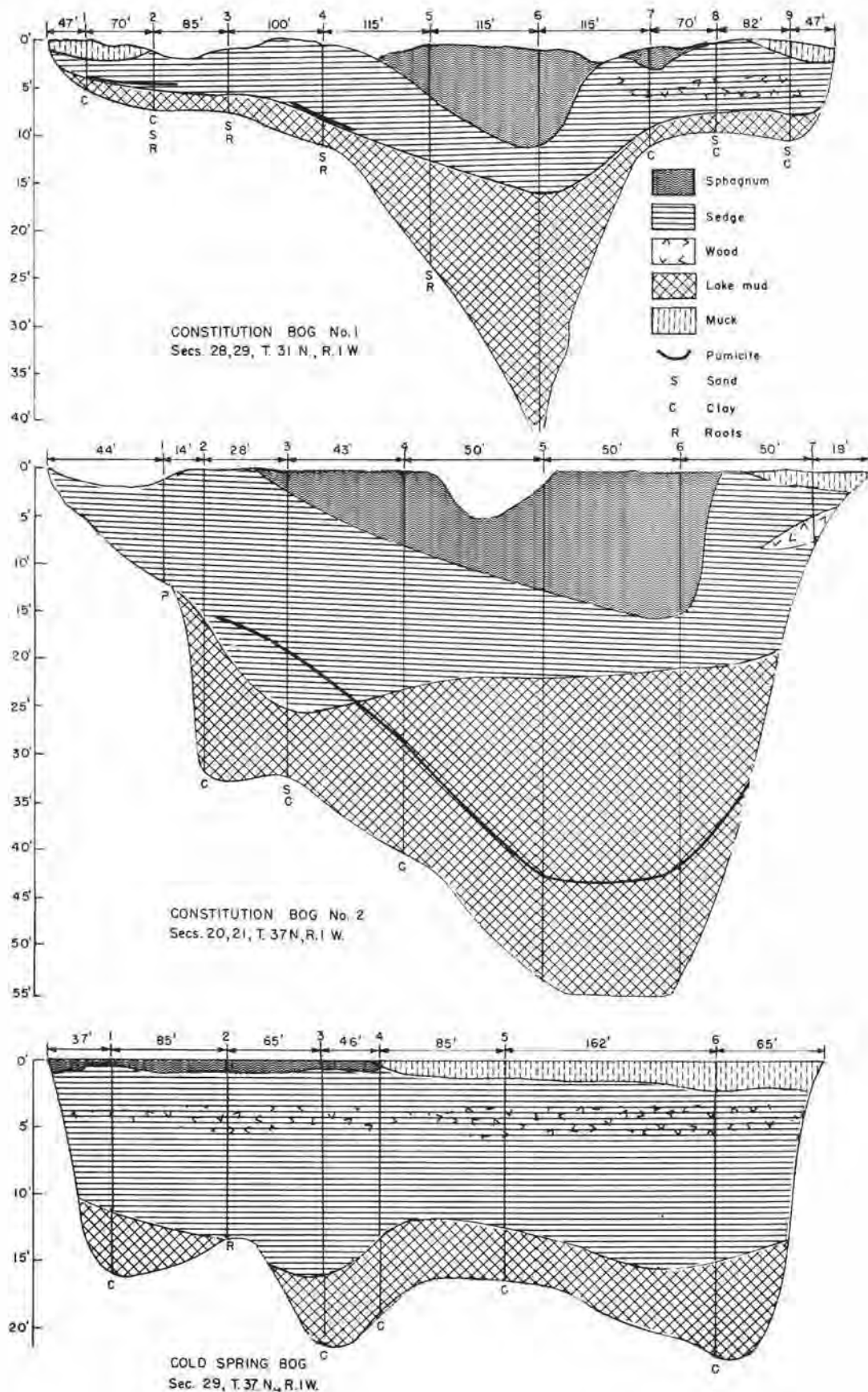

FIGURE 165.—Peat profiles in Constitution peat area No. 1, Constitution No. 2, and Cold Spring peat areas.

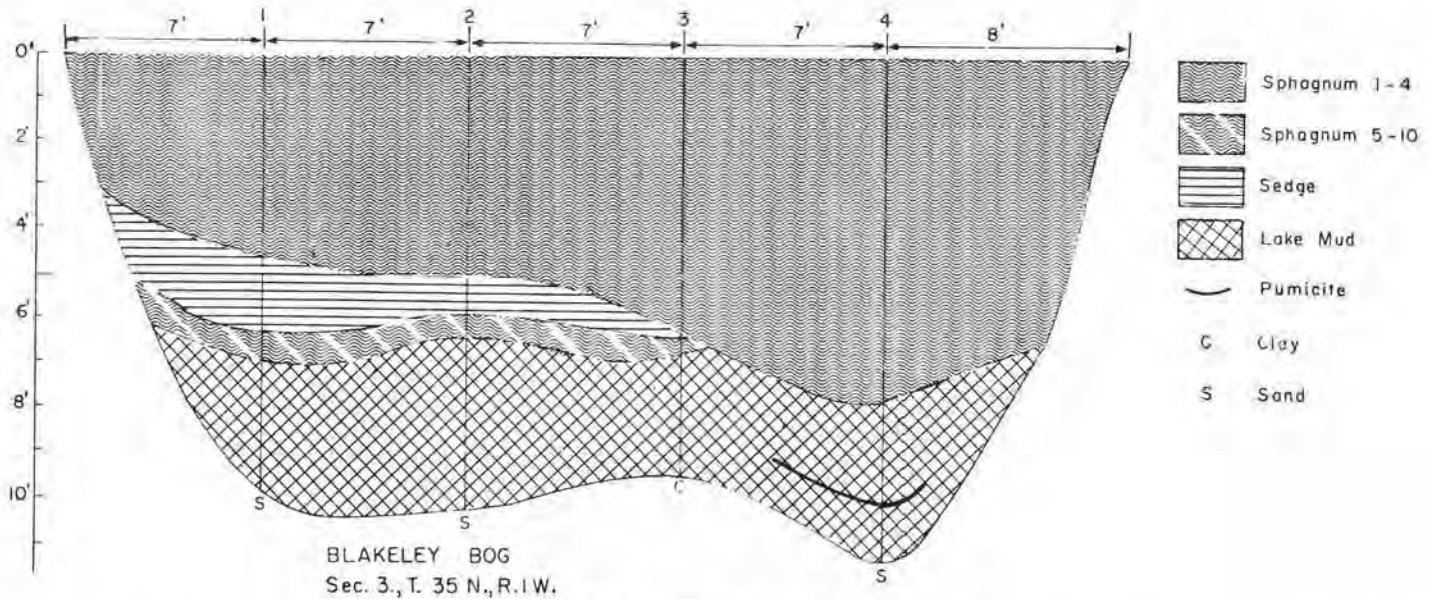

FIGURE 166.—Peat profile in Blakely peat area.

In 1938 and preceding years these marshes were studied by G. B. Rigg, L. D. Phifer, and Wilma Hudleson (now Mrs. Lyle Swain). None of the data obtained have been published. Undoubtedly there are a number of small marshes which were not included in the study, but the ones that were studied include the largest and most important ones, and the discussion covers the main features of salt marshes in the county.

Three of the largest salt marshes are on Henry Island—two of them (Nos. 1 and 2) on the neck of land lying between the head of Open Bay and the head of Nelson Bay and one (No. 3) on the shore bordering Mosquito Pass.

Thirteen are on San Juan Island. The largest of these are at the head of Wescott Bay (No. 4), the head of Garrison Bay (No. 5), and the head of Mitchell Bay (No. 6). All of these are on the west shore near the north end of the island. There is a small marsh on either side of Mineral Point (Nos. 7 and 8), on the northeast shore of the island. Three are in the vicinity of Friday Harbor—one of them (No. 9) bordering the bay south of Brown Island, one (No. 10) on the point near Turn Island, and one (No. 11) near Argyle. Four (Nos. 12, 13, 14, and 15) are on the north shore of the peninsula at the extreme southeast end of the island, and one (No. 16) is on the east shore of this peninsula.

Eight marshes are on Lopez Island. One (No. 17) is on the west shore of the island on the narrow neck of land lying between Fisherman Bay and San Juan Channel, and one (No. 18) is on the point of land across the bay from the neck. One (No. 19) is south of Humphrey Head on the northeast shore of the island on the neck of land lying between Shoal Bay and Swifts Bay. One (No. 20) borders Swifts Bay at the mouth of a stream near Port Stanley. Another (No. 21) is on Spencer Spit southeast of Swifts Bay. Another (No. 22) is on the southeast shore of the island on the narrow neck of land lying between Mud Bay and Shoal Bight. Two are on the south-

west shore of the island—one of them (No. 23) on Davis Bay and one (No. 24) on Mackaye Harbor.

Eight marshes are on Shaw Island. Four of these (Nos. 25, 26, 27, and 28) are in the vicinity of Neck Point at the northwest end of the island. One of them (No. 25) is on a narrow neck of land. Three marshes (Nos. 29, 30, and 31) border Parks Bay on the southwest shore of the island. A fairly large one (No. 32) is on the southeast shore on Indian Cove, opposite Canoe Island.

A rather large one (No. 33) is at the north end of Blakely Island. It borders a small bay just south of Peavine Pass. One (No. 34) is on the north end of McConnell Island. On Stuart Island there is a small marsh (No. 35) on a narrow neck of land at the east end of the island, north of Johns Pass.

The plants that grow in salt marshes are quite different from those that grow in ordinary habitats. Though they differ among themselves in form and structure, they all have in common the ability to grow in soil which contains sea water and the ability to stand flooding at high tide. Ordinary land plants are killed by such conditions.

The two species which are most common in the salt marshes of San Juan County are glasswort (salthorn) and salt grass. Each of these has its own way of surviving in soils containing significant amounts of sea water.

Glasswort is a fleshy plant having stems about the size of a lead pencil or considerably smaller. Its leaves are only rudimentary and are not commonly recognized as leaves at all. The stem is green and it carries on the process usually carried on by leaves. In the center of the stem there is a slender woody strand about the size of ordinary wrapping twine. Around this is a thick fleshy layer of soft green tissue. When this tissue becomes full of salt it is sloughed off and only the woody strand remains. New fleshy green tissue is then formed on the young internodes near the growing top of the stem.

Salt grass has no fleshy tissue. Its leaves and stems are harsh to the touch. It gets rid of excess salt by ex-

creting it on the surface of the leaves. Crystals of common salt can be seen on the surface of the leaves even with the unaided eye. Many other species grow in salt marshes or around their margins. Some of them have no obvious means of tolerating salt, but they do tolerate it in one way or another. Many of these species are fleshy and have some structures in common with glasswort.

The salt-marsh peat is shallow. It has been investigated by digging, and no peat more than 3 feet deep has been found. There may be deeper peat than this, but it seems improbable. In many marshes the peat is less than 2 feet deep, and in some it is only 6 inches. The peat is fibrous. Most of it has originated from the remains of species of plants that are peculiar to salt marshes, but some of it which was formed in later stages of development has originated from the remains of ordinary land plants, mainly grasses.

The salt marshes fall naturally into two groups—those which have a low ridge (bar) of gravel and sand in front of them separating them from the sea, and those which slope gradually down to the sea without obstruction. The gravel ridge commonly has an opening through which sea water enters at high tide and floods the marsh. Whether there is a ridge or not, the salt water usually comes into the marsh through numerous crooked channels which form a complicated system throughout the marsh. Among the salt marshes which have a ridge at the front are numbers 17, 19, 20, 21, 33, and 34. Good examples of those that slope gradually down to the sea without obstruction are numbers 4, 5, and 6.

Whether a ridge of gravel and sand is formed or not depends on the configuration of the shore and the direction and force of the waves and tidal currents. The situation is never static, and both constructive and destructive changes in the ridges are going on at the present time.

Each salt marsh as it exists now is merely a stage in development. In addition to the physical factors mentioned above, the development is also determined by the accumulation of the remains of the plants that grow there. As the marsh is gradually built up, the surface may become high enough so that land plants which are somewhat tolerant of salt will invade the margin of the marsh. The building up of the surface is often aided by the inwash of organic and inorganic materials from the surrounding slopes.

Considerable use has been made of salt marshes in the county. Several of them are used in their natural condition as pastures. The ones on which the vegetation consists mainly of salt grass are used most, and the pastures often include some adjoining land on which ordinary forage plants grow.

Some marshes have been at least partially reclaimed by ditching, diking, and the installation of tide gates. The marsh bordering Davis Bay (No. 23) is a good example of such reclamation. When last observed (about 1938), some of it was in pasture and some was in cultivation. Examples of marshes used for pasturage in their natural condition are two on Henry Island (Nos. 1 and 2) and one on Shaw Island (No. 32).

The reclamation of salt marshes is slow and expensive.

Salt persists in their soil for a long time, and many crop plants are sensitive to even small amounts of salt. The activities of the sea must also be reckoned with. The rise and fall of the tide and the destructive action of waves and currents present many difficulties.

The salt marshes of San Juan County are typical of those found along the shores of other counties of the state, except that deep peat is present in two marshes in Island County (Crockett Lake and Hancock Lake) and one (Shine) in Jefferson County. Some information about salt marshes in Skagit and Whatcom Counties is given in the description of peat areas in those counties, and two large areas are mentioned in the discussion of Pierce County peat areas.

SKAGIT COUNTY DEPOSITS

Burlington peat area

The Burlington peat area (616 acres) is in secs. 26, 27, 35, and 36, T. 35 N., R. 3 E., about 1½ miles by paved road east of Burlington. This road crosses the peat (map, fig. 167). The deposit is shown as peat and muck on the Bellingham sheet of the Soil Survey of the Eastern Part of the Puget Sound Basin (Mangum, 1911) and as peat on the unpublished soil map of the Soil Conservation Service. The topography of the region is shown on the Mount Vernon quadrangle (U. S. Geological Survey). On the southwest side the peat is bordered by a ridge of glacial drift which reaches a height of 200 feet. On the other sides it is bordered by alluvial soil which is less than 25 feet above sea level. The peat is drained by a ditch from which the water eventually reaches Padilla Bay. Laterals provide drainage into the main ditch.

There are dairy farms on the peat, and most of the area is in cultivation. Among the crops are hay, grass for drying, oats, potatoes, corn, and peas.

The profile is parallel to a ditch and about 15 feet from it. It extends through fields of potatoes, corn, and oats. The materials revealed in it (fig. 167), are fibrous peat, woody peat, muck, and clay. Each of these materials is found in some places as pure layers varying in thickness from 3 inches to 2 feet, but these layers continue for only short distances. In other places two or more of the materials are mixed together. The borings indicate that there have been many local changes in the conditions under which the materials were deposited. The deposit is so complex that it is difficult to represent details of the various layers and mixtures on the scale usually used in profiles. For this reason the entire profile is shown as a mixture of the four materials.

The fibrous peat is brown to dark brown, and much of it is decomposed. Some of it is watery. The deposit rests on blue clay, but the clay present in mixtures and layers is gray. The muck is brown. Logs, large pieces of wood, and masses of leaves are present near the south end of the profile (holes 8, 9, and 10). Bottom was not reached in holes 9 and 10 because the muck and wood were too compact to be penetrated with the peat borer. Tests made at holes 4 and 5 indicate that the peat is strongly acidic (pH 4.5). Holes A and B are in waste land near a well. Hole C is in a hayfield,

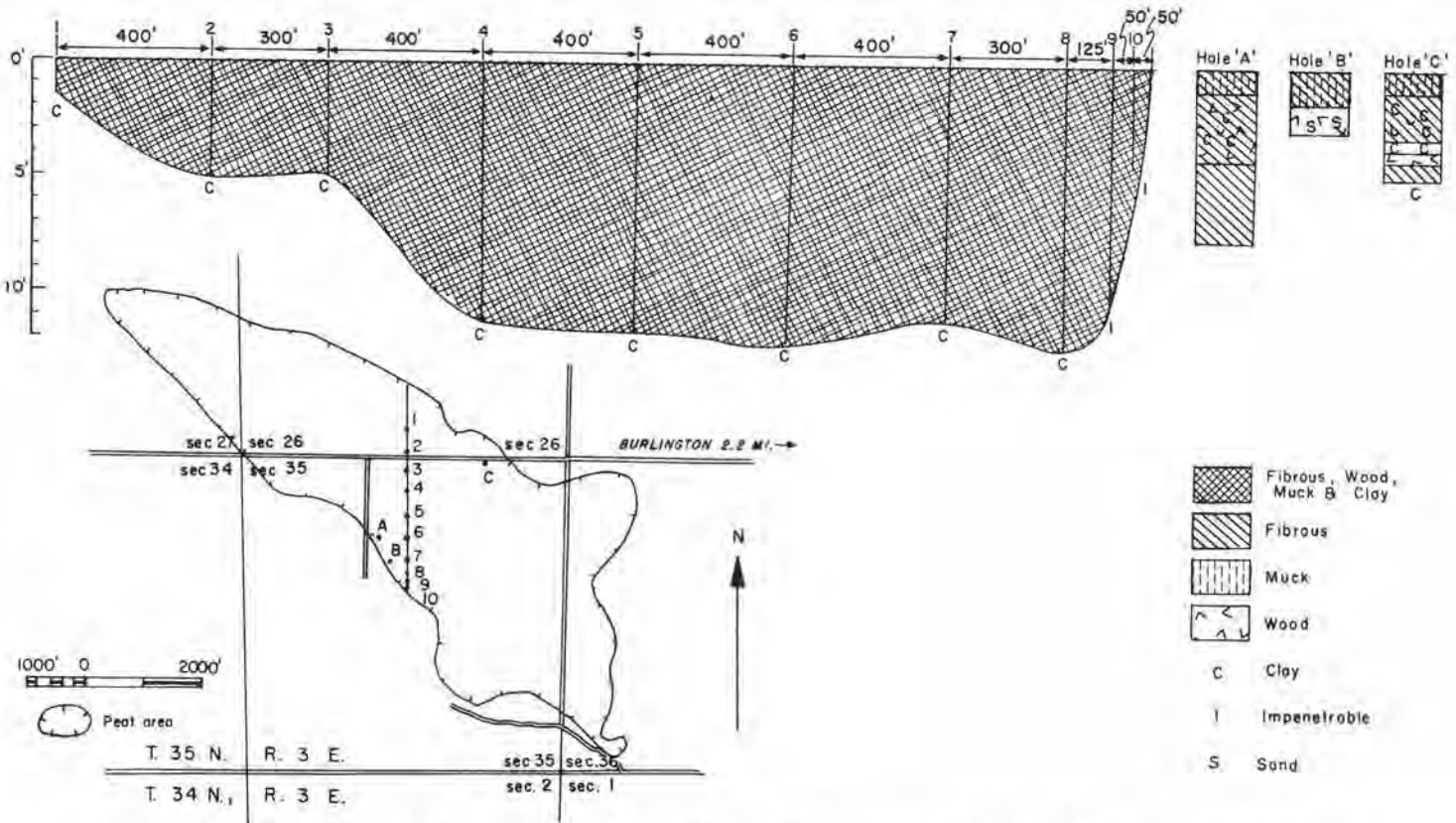

FIGURE 167.—Map, profile, and graphic logs of three holes in Burlington peat area (616 acres). Map adapted from U. S. Soil Conservation Service soil map.

Dachnowski-Stokes (1936) reports observations made on open ditches in this peat. He found 5 feet of material which was mostly organic lying on a substream of sticky bluish-gray clay. He characterizes the upper 14 inches of this as "dark grayish-brown moderately firm and partly decomposed fibrous sedge peat" (pH 5.5) with muck near the surface. He describes the material from the 14-inch to the 60-inch level as "dark chocolate-brown or grayish-brown sedimentary-fibrous sedge peat which is layered and is acid in reaction (pH 5). It contains seeds of various species of herbaceous plants and small crystals of some salt in excess. At variable depths, usually between 23 and 36 inches below the surface, the layer is stratified with stream-borne silt and clay. At the lower level the material consists of greenish-gray silty organic sediments which are slightly acid in reaction (pH 6) and show iron-stained root channels alternating with grayish-brown silty and clayey fibrous materials. At greater depths the stratified layer contains greenish-gray clay, and toward the bottom the material resembles a mixture of organic residue and clay, having its origin probably in the waste of earlier flood waters."

Milltown peat area

The Milltown peat area (269 acres, including 3 acres of sphagnum) is in secs. 27 and 34, T. 33 N., R. 4 E. (map, fig. 168), about 3 miles east of Milltown. It is reached by turning east from U. S. Highway 99 on a county road about 7 miles south of Mount Vernon. A stream of brown slimy

water originates in the eastern part of the area and flows west of Skagit Bay.

Most of the area has been logged, and there is evidence that it was a swamp forest consisting of fairly large coniferous trees. In 1951 there were large quantities of roots, stumps, and general logging debris which had been piled for burning.

At the east end of profile A near the creek the vegetation consists mostly of willow, alder, and crab apple. Along the rest of this profile the vegetation is composed of skunk cabbage, reeds, scouring rushes, and grasses.

The profile (fig. 168) shows a large amount of a mixture of fibrous peat and woody peat which ranges in color from brown to dark brown. The fibrous peat, whether alone or mixed with woody peat, is mostly disintegrated. The sedimentary peat is olive. The pumicite is white, and the layer is about 1 inch thick. The deposit rests on clay, sand, and gravel. The clay is blue and soft.

Profile B is in a sphagnum bog which is the remainder of a more extensive bog, much of which has been destroyed by a recent fire. The vegetation consists of bog shrubs and herbaceous bog species which have survived the fire, together with fireweed, evergreen blackberry, and some grasses which have invaded the area since the fire. Labrador tea is regenerating from the bases of old stems which survived the fire.

The sphagnum is light brown. Some of it is raw and of good quality, some is disintegrated, and some is dry. The fibrous peat is brown and decomposed. The sedi-

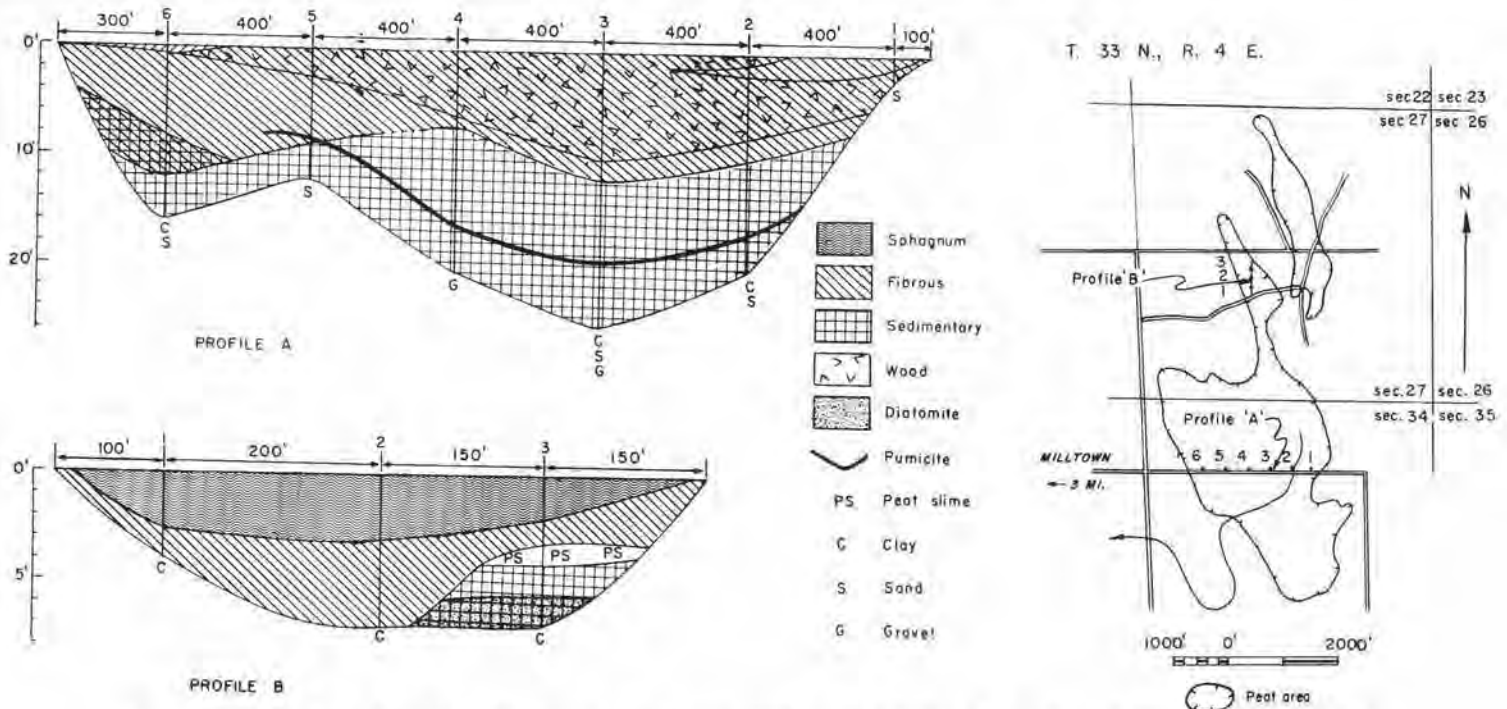

FIGURE 168.—Map and profiles of Milltown peat area (269 acres, including 3 acres of sphagnum). Map adapted from U. S. Soil Conservation Service soil map.

mentary peat is mostly dark brown to olive brown but is light brown at the bottom where it is mixed with diatomite. The deposit rests on clay which is gray at holes 1 and 2 but is blue-gray at hole 3.

The fibrous and woody peat range from strongly acidic (pH 4.7) to weakly acidic (pH 5.0). The sedimentary peat ranges from strongly acidic (pH 4.7) to very weakly acidic (pH 6.0). The pH of the water of the creek is 4.8.

Green trees are still standing on the isolated area (map, fig. 168) northeast of the main deposit. No boring was done in this area.

Sedro Woolley peat area

The Sedro Woolley peat area (62 acres) is in sec. 31, T. 36 N., R. 5 E.; sec. 6, T. 35 N., R. 5 E.; and sec. 36, T. 36 N., R. 5 E., about 3½ miles by road north of Sedro Woolley. It surrounds a lake (map, fig. 169). Hansen (1941) wrote, "The depression in which it [Sedro Woolley bog] has been formed had its origin as a kettle pond in terraced outwash of the Samish River." The elevation of the peat is a little less than 350 feet above sea level.

Aquatic plants grow in the margin of the lake, and semiaquatic and marsh plants on the shore. The marsh merges into a very wet sphagnum bog in which grow the usual bog herbs and shrubs together with much hardhack. There is some swamp forest in the margin of the bog, and some of the trees are dead.

In the profile (fig. 169) the peat at the margin of the lake is 33½ feet deep, and 800 feet north of the lake it is 31 feet deep. These depths indicate that this peat de-

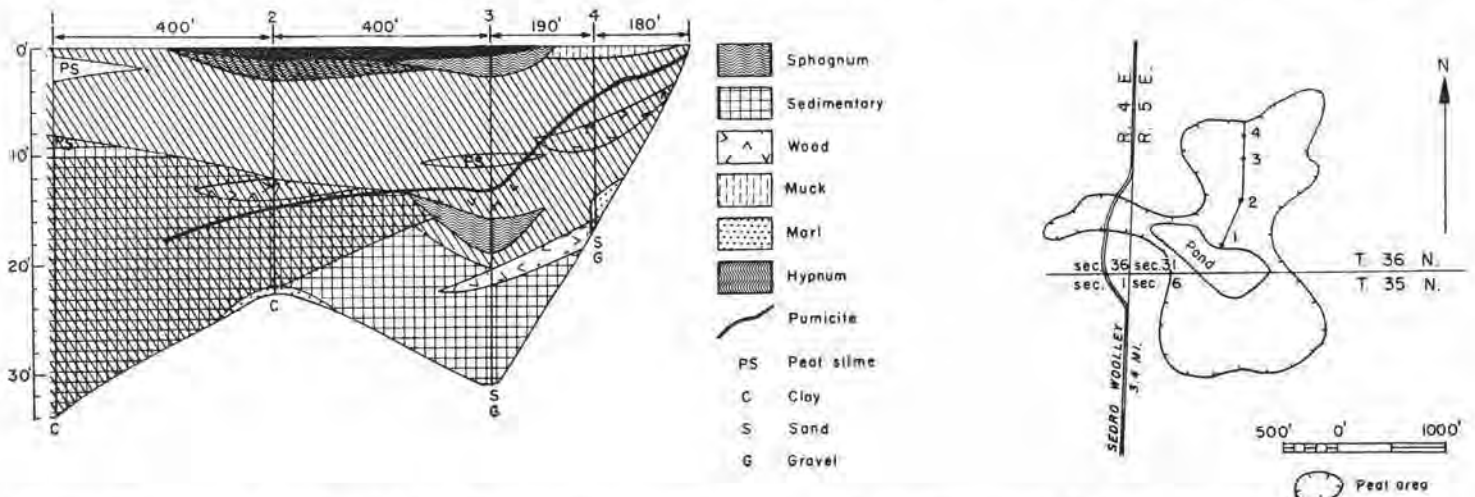

FIGURE 169.—Map and profile of Sedro Woolley peat area (62 acres). Map adapted from U. S. Army Map Service photomosaic.

posit was laid down in a comparatively deep lake. The mixture of sphagnum and hypnum is brown. The sphagnum under it is partially disintegrated. The sphagnum at the 16- to 19-foot depth in hole 3 is brown and decomposed. The fibrous peat throughout the profile is wet, and much of it is decomposed. Peat slime and woody peat occur at several levels. The sedimentary peat is olive where it is pure, and the mixture of fibrous and sedimentary peat is brown. The marl is a yellowish gray-green color. This is one of the few peat deposits in western Washington in which marl is found, and the quantity of it here is not large.

The pumicite in holes 3 and 4 is brown, and the layer is only half an inch thick in hole 3. In hole 2 some of it is brown and some is white, and it is somewhat mixed with the peat. The clay at the bottom of holes 1 and 2 is blue. At the bottom of hole 3 the mixture of sand and pea-size gravel is dark gray. Gravel is present at the bottom of hole 4.

Hansen (1941) bored a hole 50 feet south of the south shore of the lake. He found 7.25 meters (23 feet 9 inches) of peat which comprised 4 meters (13 feet 1 inch) of brown fibrous peat and 3.25 meters (10 feet 8 inches) of limnic (sedimentary) peat. Under the sedimentary peat he found 2.25 meters (7 feet 5 inches) of blue clay with a distinct metallic sheen. He says that the clay "was probably carried into the lake in late glacial or early postglacial times before the invasion of forests, as it is entirely devoid of pollen." He also says, "No volcanic ash [pumicite] was found either as a layer or dispersed crystals [sic]." He found *Sphagnum* leaves in the peat down to a depth of 6.5 meters (21 feet 4 inches). He notes that the southern part of the area is annually cut for hay.

Sawmill peat area

The Sawmill peat area (48 acres) is in secs. 27 and 28, T. 36 N., R. 8 E. (map, fig. 170), and about 2½ miles north of Concrete. A road passes within a few hundred feet of the western border of the peat.

Water stands on most of the area. Much of it is covered with a thick growth of hardhack brush. In places which are not covered with hardhack, *Dulichium*,

a low herbaceous plant belonging to the sedge family, grows in the water. In June 1950 the water was too deep to permit making a profile.

One hole (fig. 170) near the northwest border of the area shows 14 feet of peat and 10 inches of brown muck

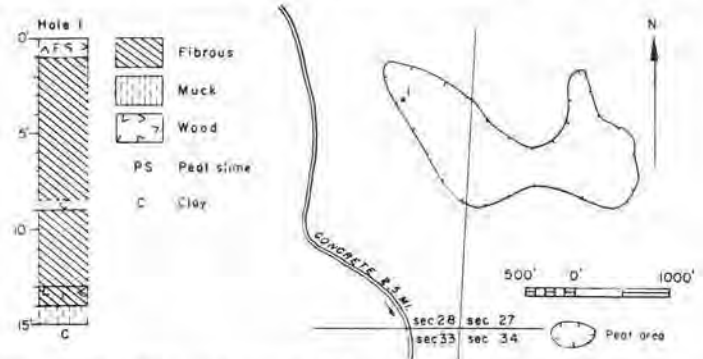

FIGURE 170.—Map and graphic log of a hole in Sawmill peat area (48 acres). Map adapted from U. S. Army Map Service photo-mosaic.

which rests on blue clay. There is a 2-inch layer of clay at the 9-foot depth. The upper 1 foot is a mixture of peat slime and woody peat. The fibrous peat is dark brown and decomposed.

Hamilton peat area

The Hamilton peat area (33 acres) is in secs. 5 and 8, T. 35 N., R. 7 E. (map, fig. 171), about 3 miles northeast of Hamilton, which is on State Highway 17A. The peat lies in an undrained depression in glacial drift on a forested flat (elevation 500 feet above sea level) from which the land slopes abruptly south down to a terrace of the Skagit River.

It is a sphagnum bog with a characteristic natural "marginal ditch." The dominant shrubs on the bog are Labrador tea and bog laurel. The herbaceous plants are cotton grass and sundew. The moss cover is living *Sphagnum* and *Hypnum*. The most abundant tree is lodgepole pine, but there is some white pine. The former range from 3 to 8 inches in diameter and the latter, from 6 to 8 inches. The characteristic vegetation in the mar-

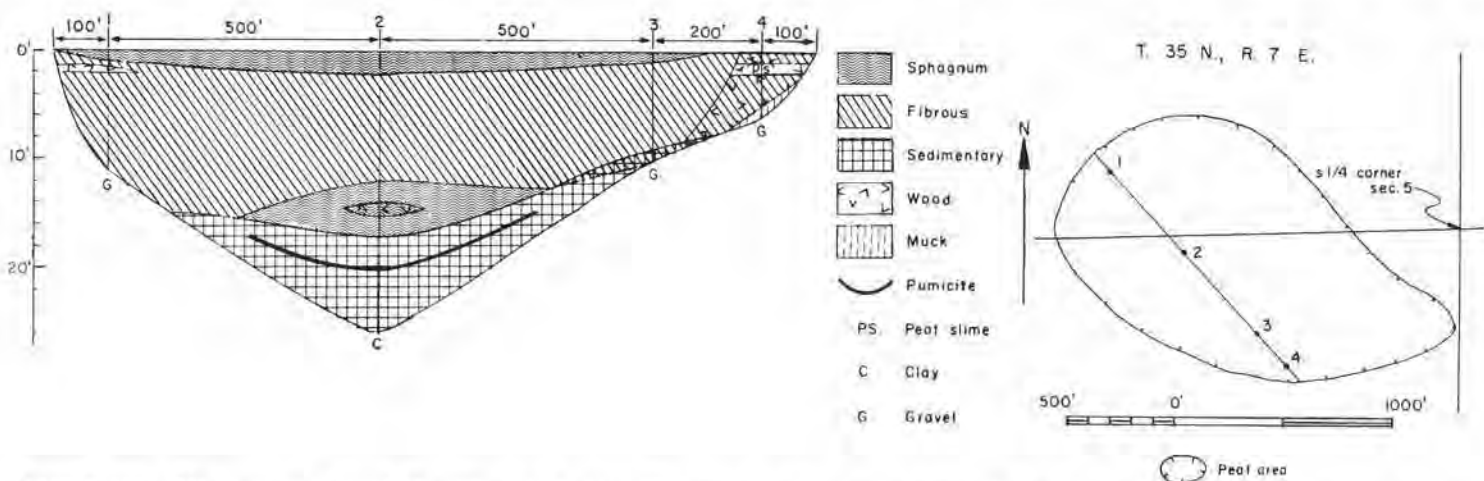

FIGURE 171.—Map and profile of Hamilton peat area (33 acres). Map adapted from U. S. Soil Conservation Service soil map.

ginal ditch includes alder, crab apple, and skunk cabbage.

The forest north of the bog is composed mostly of alder and cottonwood, but there are some young conifers. Old fir stumps indicate logging some years ago.

The profile (fig. 171) shows sphagnum at the surface, with a maximum depth of 2 feet, extending through 1,180 feet of its 1,400-foot length. The sphagnum is light brown to dark brown and is mostly raw. The sphagnum at the 12- to 16-foot depth is decomposed, and some of it is mixed with twigs. The fibrous peat is light brown to dark brown and is decomposed. Some of it is watery. The sedimentary peat is olive brown. The pumicite found in hole 2 is white, and the layer is about 1 inch thick. Gravel is present at the bottom of holes 1, 3, and 4, and blue clay occurs at the bottom of hole 2. No evidence of any attempt at utilization was seen.

Lake Campbell peat area

The Lake Campbell peat area (27 acres) is in sec. 13, T. 34 N., R. 1 E. It is about 4 airline miles south of Anacortes, but the distance by road from Anacortes to the south end of the peat is considerably greater. It is less than 2 airline miles northeast from the east end of the Deception Pass bridge. The area borders the southwest shore of Lake Campbell (map, fig. 172) and is less than 50 feet above sea level (Deception Pass quadrangle). The land rises abruptly to a height of 250 feet or more on the east and west sides of the peat. Between the south end of the peat and the north shore of Pass Lake, a distance of perhaps 1,500 feet, the slope is more gentle and the total rise is about 100 feet.

The peat area is very wet, and much of it is a swamp forest with a dense undergrowth of shrubs. In some open places there is an abundant growth of marehail, which is an aquatic plant. One small area has been plowed, but its extreme wetness and the fact that the plow has turned up a considerable amount of diatomite indicate that the

soil is of doubtful value for agricultural use. The northern part of the area is extremely wet and was not explored.

The profile (fig. 172) shows an unusual amount of marl for a western Washington peat deposit. The marl is tan to olive tan in color, and it contains small gastropod shells. It is neutral (pH 7.0). The muck is dark brown to black and is strongly acidic (pH 4.2). The fibrous peat is light brown to dark brown and is raw to decomposed. The sedimentary peat varies in color from brown to olive to olive green. No pumicite was found.

The deposit rests on clay which varies from gray to blue. It is mixed with sand in hole 1 and contains fragments of shells in hole 2.

Walker Valley peat area

The Walker Valley peat area (25 acres) is in sec. 5, T. 33 N., R. 5 E., about 3 miles southeast of the village of Big Lake and about 8 miles southeast of Mount Vernon. It is shown as marsh on the Clear Lake quadrangle. The benchmark on the north line of sec. 5 shows an elevation of 236 feet above sea level. There is some drainage from the peat area to Walker Creek, which flows north to the Skagit River. An old logging road extends near the eastern border of the peat. On the Bellingham sheet of the Soil Survey of the Eastern Part of the Puget Sound Basin (Mangum, 1911), Walker Valley is mapped as Bellingham silt loam.

This is a sphagnum bog with the usual flora of bog herbs and shrubs and the usual swamp zone around the margin. There are some drainage ditches on the bog, but beaver dams obstruct the drainage to the creek, and the bog continues to be very wet.

A few borings made by Rigg in 1945 indicate that the peat is 20 feet or more in depth. There is some sphagnum peat, but its depth has not been determined.

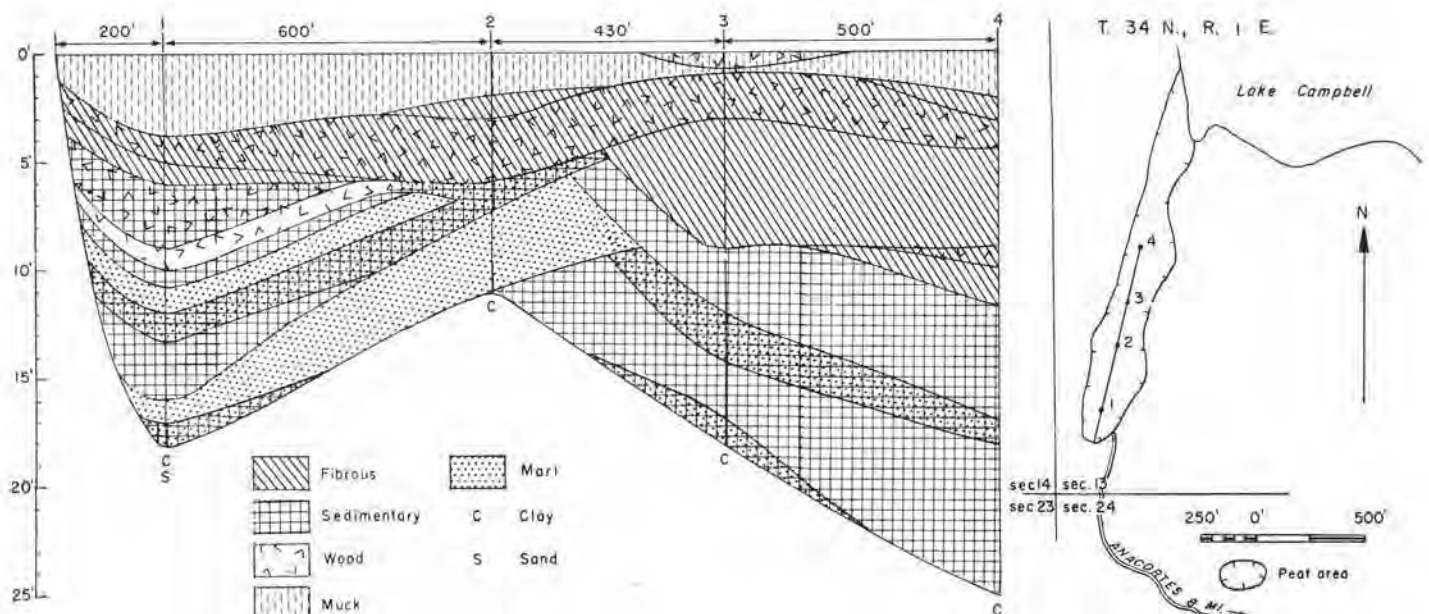

FIGURE 172.—Map and profile of Lake Campbell peat area (27 acres). Map adapted from U. S. Soil Conservation Service soil map.

Devils Mountain peat area

The Devils Mountain peat area (estimated 14 acres) is in secs. 3 and 4, T. 33 N., R. 4 E., at an elevation of about 575 feet on the west slope of Devils Mountain about 3 miles southeast of Mount Vernon. It is reached by a trail (formerly a road) from the road which extends along Carpenter Creek.

The area is a sphagnum bog from which sphagnum moss was removed some years ago and marketed locally. Old partially burned buildings still stand at the margin of the bog at the end of the old road, and there are some mechanical devices nearby which were used in removing and handling moss.

The bog is in the Devils Mountain Game Refuge, and a beaver dam now obstructs drainage so that the bog is flooded to a depth of 4 or 5 feet. Observations made from logs about 25 feet from shore show 2 to 3 feet of water and muck with gravel under the muck. The vegetation there is composed of Labrador tea and hardhack.

The present owner, A. Pollard of Mount Vernon, stated that he visited the bog before it was flooded and thrust an iron pipe down 30 feet. At that depth he encountered something solid. Nearer the margin he encountered something solid at 12 feet.

Carpenter Creek peat area

The Carpenter Creek peat area (estimated 5 acres) is in sec. 4, T. 33 N., R. 4 E., about 3 miles southeast of Mount Vernon. It lies along Carpenter Creek and the road that parallels it near the beginning of the trail leading to the Devils Mountain peat.

Some peat has been removed from the Carpenter Creek deposit by the use of power machinery. No borings were made, but the indications are that the deposit consists of shallow fibrous peat.

Big Lake peat area

The Big Lake peat area (12 acres) is in secs. 16 and 17, T. 33 N., R. 5 E. (map, fig. 173), about 8 airline miles southeast of Mount Vernon. It is about 2 miles southeast of the south end of Big Lake and about 3 miles southeast of Montborne. It lies near a creek which flows to Big Lake with a fall of a little more than 150 feet (Mount Vernon quadrangle). The land rises rather abruptly on both sides of the flat through which the creek flows. The soil of the flat in which this peat lies is mapped as Bellingham silt loam on the Bellingham sheet of the soil survey (Mangum, 1911).

This is a sphagnum bog that has developed in a deep lake, a part of which still remains as an open pond. In 1950 part of the bog was flooded because of a beaver dam in the creek. The eastern part of the bog surrounding the pond is a mat of vegetation on which *Sphagnum* grows with sundew, native cranberry, and Labrador tea. Also, there are small dead coniferous trees in some places and hardhack in others. Cattails grow around the margin of the pond.

West of the pond some plants not characteristic of sphagnum bogs grow with the bog plants. Among these are black twinberry, which is a tall shrub; a species of scouring rush (*Equisetum fluviatile*) that is characteristic of shallow water at the margins of ponds; a species of

wintergreen (*Pyrola* sp.) which is a low perennial herb; and some scattered dogwood trees. There are also some scattered small cedar trees. The western part of the peat area was not investigated.

Each of the two holes bored in this peat area is 50 feet deep (fig. 173), and bottom was not reached in either because no facilities for boring deeper were at hand. The

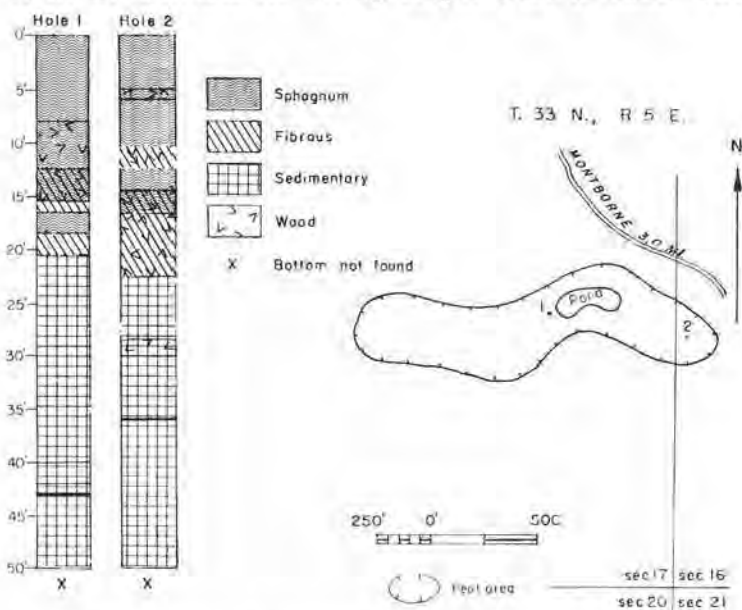

FIGURE 173.—Map and graphic logs of two holes in Big Lake peat area (12 acres). Map adapted from U. S. Army Map Service photomosaic.

pure sphagnum revealed in these holes is raw and wet and is in two layers. There is also some sphagnum mixed with the small leaves of heath shrubs, some mixed with twigs, and some mixed with sedge peat and woody peat. The fibrous peat is brown to dark brown and is mostly watery. Some of it is mixed with woody peat, and some of it with twigs. The sedimentary peat is brown to olive brown to olive green. It is compact near the bottom but not too compact to be penetrated with the peat borer. It contains some very thin layers of clay near the bottom of hole 1. The pumicite is white, and the layer is 3 inches thick in hole 1 and 2 inches in hole 2.

There is considerable sphagnum in this bog, and so far as seen it is suitable for marketing. The bog is so wet, however, that floating equipment would have to be used in removing this peat. There would be considerable loss of volume and weight due to the high water content. The fact that some of the sphagnum is mixed with other materials might affect its market value.

Pilchuck Creek peat area

The Pilchuck Creek peat area (12 acres) is in secs. 21 and 22, T. 33 N., R. 5 E. (map, fig. 174), about 5 miles southeast of Montborne and about 9 airline miles southeast of Mount Vernon. The road from Montborne crosses the peat and intersects another road a few hundred feet south of it. The peat is about 1 mile west of Pilchuck Creek, which flows into the Stillaguamish River. It is at the divide between the Pilchuck Creek drainage and that of a creek which flows into Big Lake. A benchmark near

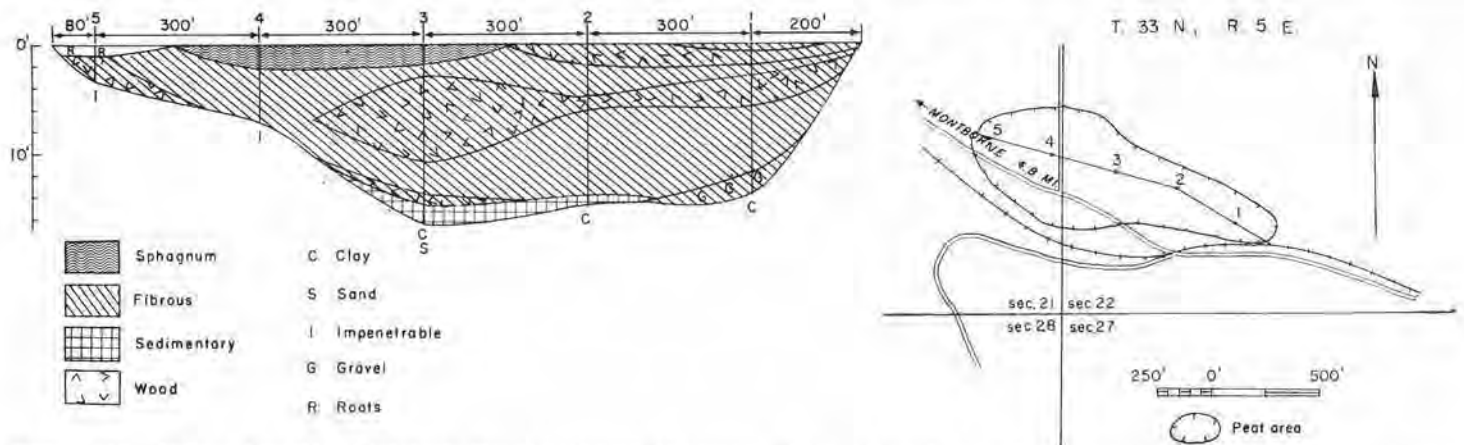

FIGURE 174.—Map and profile of Pilchuck Creek peat area (12 acres). Map adapted from U. S. Army Map Service photomosaic.

the peat shows an elevation of 536 feet above sea level (Clear Lake quadrangle).

This peat area consists of sphagnum bog, swamp forest, and hardhack swamp. Hole 1 of the profile is in the swamp forest of coniferous trees with an undergrowth of shrubs. Between holes 1 and 2 the forest of cedar, hemlock, fir, and spruce has very little shrubby undergrowth, but skunk cabbage is abundant. Between holes 2 and 3 this open forest merges into the sphagnum bog, in which *Sphagnum* and *Hypnum* grow together, and *Sphagnum* forms hummocks. The usual bog shrubs and herbs occur. Hole 5 is in the hardhack swamp.

There are many logs in this peat deposit. Some are wholly or partially embedded at the surface, and many are embedded at deeper levels. The peat at the west end of the profile evidently has been deposited in and over a log jam. Numerous attempts to bore in the vicinity of holes 4 and 5 failed to disclose any place where logs were not encountered, so bottom was not reached. Stumps are present in the vicinity of holes 3 and 5. The swamp forest, the stumps, the embedded logs, and the large amount of woody peat shown in the profile indicate that trees have played an important part in the development of this peat deposit.

The sphagnum in the profile is mostly raw, but some of it is disintegrated, and some is dark colored. The fibrous peat is brown and decomposed. The sedimentary peat is olive green. The deposit rests on blue clay, which is mixed with sand in hole 3. The peat is strongly acidic. In hole 4 the pH in sphagnum at the 1-foot depth is 3.5; in fibrous peat it is 3.5 at 4 feet, and 3.7 at 6 feet.

The easy access to this area by road would facilitate any utilization of this peat that may be possible. The sphagnum might be advantageously used locally for chicken litter or bedding for livestock. The fibrous peat might be used for agricultural purposes, but the large amount of woody peat in it must be considered. The use of this peat area as a truck garden would be possible if the temperatures are not too low. As the peat area is surrounded by land that is relatively high, there might be enough drainage of cold air into it so that the air temperature over the peat would be unfavorable for the growth of vegetables. The air drainage out of the peat area should be studied before attempting utilization for garden purposes.

Concrete peat area

The Concrete peat area (estimated 5 acres) is about 2 miles north of Concrete. It is approximately in sec. 34, T. 36 N., R. 8 E. The road leading from Concrete to Baker Lake crosses it near the east end. This peat area is curved and is estimated to be about 1,500 feet long and 150 feet wide. The depression in which it lies is probably an old river channel. It is covered with brush, mostly hardhack. Coniferous forest surrounds it.

At a point west of the road the deposit consists of 8 feet of dark-brown decomposed fibrous peat which is watery near the surface but is compact at a depth of 3 feet. Some logs or large pieces of wood are embedded in it at a depth of 4 feet. At the 2½-foot level there is a 3-inch layer of brown pumicite. The deposit rests on gravel, and there is some sand and also fine gravel mixed with the peat in the lowest foot.

Heart Lake peat area

The Heart Lake peat area (5 acres) is in sec. 36, T. 35 N., R. 1 E., about 1 mile by road south of Anacortes. It borders the south end of Heart Lake.

It is covered with a swamp forest in which there is a dense tangle of brush and logs. Herbaceous swamp plants grow in wet soil, which in some places is covered with shallow water.

One hole about 100 feet south of the lake shore shows 2 feet of muck and woody peat containing some sand, 2 feet of mixed fibrous peat and woody peat, 6 inches of mixed fibrous peat and sedimentary peat, and 2 feet of a mixture of marl and sedimentary peat. The marl contains shells. The deposit rests on blue clay and sand.

Bellville peat area

The Bellville peat area (probably less than 10 acres) is in sec. 17, T. 35 N., R. 4 E., about a mile northeast of Bellville and about 2½ miles north of Burlington.

An area of perhaps 60 acres northeast of Bellville is mapped as muck and peat on the Bellingham sheet of the Soil Survey of the Eastern Part of the Puget Sound Basin (Mangum, 1911). Digging and boring, mostly in pasture land, revealed some fibrous peat 2 feet deep, some mixed fibrous and woody peat 1 foot deep, and some mixed muck and woody peat 1½ feet deep resting on clay which varies

in color from blue to gray. Inquiry among farmers did not yield any information on peat of any consequence in the area.

Similk Bay peat area

The Similk Bay peat area (4 acres) is on both sides of a small stream near the southwest corner of sec. 10, T. 34 N., R. 2 E., about 4 miles southeast of Anacortes. A road passes close to its eastern margin.

This is a salt marsh, and what peat there is in it is salt-marsh peat. Sea water comes and goes through meandering channels with the rise and fall of the tide. Salt grass is abundant, and the area is used for pasturage.

The brown fibrous peat is 3 feet deep, but the upper 2-foot layer contains some clay. The layer from the 2-foot to the 3-foot level is very watery. The material from the 3-foot to the 6-foot level is a mixture of clay and diatomite. Below 6 feet is clay containing small clam shells.

SKAMANIA COUNTY DEPOSITS

Cayuse Meadow peat area

Only one peat bog is known in Skamania County, and it is small and of little or no economic importance. The fact that the county, except for some narrow terraces along the Columbia River and a small area of gently rolling to hilly benches in the southwest corner of the county, is rough and mountainous (p. 31) makes it an unfavorable region for the development of peat deposits of any consequence. Most of the lakes and swamps of the county are in the area between and south of Mount Adams and Mount St. Helens.

One bog in this region is known from the work of Hansen (1942). He investigated this bog and made two borings in it for the purpose of securing fossil pollen to be used in the study of forest succession in postglacial times. The following information is taken from his paper, supplemented by a conversation with him and by a few data from maps. The bog (area 5 acres) is situated in sec. 9, T. 7 N., R. 8 E., at an elevation of about 3,700 feet above sea level, about 28 miles north of the Columbia River, 16 miles southwest of Mount Adams, and 20 miles southeast of Mount St. Helens. A meandering dirt road from Carson passes about 2 miles east of the bog. There is no trail, so anyone wishing to visit the bog should consult the Forest Service for directions. This bog, known as Cayuse Meadow (Meadows), has developed near the headwaters of Big Creek, which flows into the Lewis River, which in turn flows into the Columbia River about 15 miles north of Vancouver in Clark County. The peat has accumulated in a lake which was apparently ponded by landslides from the adjacent slopes. Cayuse Meadow is shown on the Steamboat Mountain topographic quadrangle.

This is a sphagnum bog. Its surface vegetation consists of *Sphagnum* moss, buckbean, marsh fivefinger, long-leaved sundew, a sedge, a spike rush, dwarf bilberry, and bog willow. On its margin grow western white pine, a few specimens of lodgepole pine, late alder, and willow.

The peat in one boring is 2.8 meters (9 feet 2 inches) deep, and in the other 2.4 meters (7 feet 10 inches). Sand

and pumice were found under the peat in both holes. A stratum of pumicite occurs at 1.2 meters (3 feet 11 inches) in the deeper hole and at 1.4 meters (4 feet 7 inches) in the shallower one. Either Mount St. Helens or Mount Adams may well have contributed the ash.

Muck areas

At least five small areas of muck, which may also include a little peat, are shown on a U. S. Department of Agriculture unpublished soil map of Skamania County. These are in an area northeast of Wind Mountain, in the southeastern part of T. 3 N., R. 8 E.

SNOHOMISH COUNTY DEPOSITS

Frye peat area

The Frye peat area (1,975 acres), commonly known as Frye Marsh, is in secs. 2 and 3, T. 27 N., R. 6 E., and secs. 26, 27, 28, 33, 34, and 35, T. 28 N., R. 6 E. Its eastern border is about 1 mile northwest of Monroe. U. S. Highway 2 (State 15) crosses the peat, and another road passes close to its southern border. The Great Northern Railway and the Chicago, Milwaukee, St. Paul and Pacific Railway cross the peat (map, fig. 175).

The peat area lies on the broad level floor of a valley in which there is now no major stream but which is continuous at both ends with the Snohomish River Valley. Evidently this 6-mile stretch of the valley was occupied by the Snohomish River until late Pleistocene time, when the river was diverted to its present channel about 2 miles to the south.

The topography of the region is shown on the Everett quadrangle (U. S. Geological Survey). The elevation of the western part of the peat area is less than 25 feet above sea level. The eastern part is slightly higher, but none of it, except a small arm of the northeastern part, is as much as 50 feet above sea level. A benchmark at the northern border of the peat in sec. 35 shows an elevation of 26 feet. In its eastern part the peat covers the entire valley floor, and the land rises rather steeply on both the north and south sides. The rise on the north side is more than 100 feet, and on the south, more than 500 feet. At the western end the peat does not occupy the entire valley, the land on the north side being only a few feet higher than the peat. French Creek, which flows into the Snohomish River, drains this part of the valley. The peat is drained to French Creek by a large ditch.

The main part of this peat area is mapped on the soil map of Snohomish County (Anderson et al., 1947) as Mukilteo peat. The part at the western end which is covered with swamp forest is mapped as Rifle peat, as is also the northeastern arm, which extends into sec. 26 and is at a higher elevation (up to 100 feet) than the main body. There are also three small areas mapped as Rifle peat, shallow phase, along the eastern border of the peat in secs. 2 and 35.

The profile (12,900 feet long) extends along the north bank of the drainage ditch. It begins at the east in a cultivated field and crosses another cultivated field, the total distance across the two fields being 4,000 feet. It then extends 6,400 feet across a field on which grass is grown for drying for use as a constituent of animal foods. The

last 2,500 feet at the west end of the profile is in a swamp forest.

The deposit (fig. 175) consists mainly of a mixture of fibrous peat and woody peat in which the former practically always constitutes more than 50 percent and in some places as much as 85 percent. In the fields the surface layer to a depth of about 1 foot consists of peat soil, the physical condition of which has been somewhat modified by cultivation. In the swamp forest the surface layer has been disturbed by the digging of the ditch. Fibrous peat not mixed with other materials is found at various depths. The amount of muck and mixed muck and fibrous peat is small. A small amount of clay is present in three holes. In hole 5 clay forms paper-thin layers at about the 2-foot level. In hole 13 it is mixed with the fibrous peat at the 3- to 4-foot depth, and in hole 15 it is similarly mixed at the 5- to 6-foot level. In hole 8 the remains of scouring rush stems are mixed with the peat at the 4- to 6-foot depth. In hole 12 some leaves are mixed with the peat at the 1- to 3-foot depth. The deposit rests on clay and sand and mixtures of the two. The color of the clay ranges from gray to greenish gray to bluish gray to blue.

The fibrous peat varies from coarse raw sedge near the surface to fine fibers at greater depths. In the western part of the profile the fibrous peat at lower levels is partly or even completely decomposed. Some of the fibrous peat is very wet, but most of it has only moderate water content. The muck is black. The woody peat is brown. The peat is very weakly acidic (pH 6.2 to 6.8).

Hole A, which is 625 feet southwest of hole 7 of the profile, is in waste land near the excavation from which peat for marketing has been removed. It shows 9 feet of peat which is similar to that found in the profile.

Water is pumped from the drainage ditch for irrigation of the grass-producing field as needed.

In 1949 a Heil dryer was used by Floyd McKennon, Route 2, Snohomish, for drying grass grown on the peat. Some peat was treated in this dryer at times when it was not needed for drying grass. The peat was stockpiled and partially air-dried before treatment in the Heil dryer, where in a few minutes it was finely ground and dried. A balanced mineral fertilizer was mixed with this peat as it came from the dryer, and the product was sacked for the market.

Dachnowski-Stokes (1930) has described peat which he observed in exposed banks of an excavation 3 to 4 feet deep. He locates this excavation as "in T. 27 N., R. 6 E., sec. 1, southeast of Monroe." This location, however, is west of Monroe, and the soil map of Snohomish County (Anderson et al., 1947) indicates that the excavation investigated must have been in sec. 2 of the Frye peat area. Rigg was with Dachnowski-Stokes when the field study was made, and his memory confirms the location of the peat as shown on the soil map. In general, the description of the peat by Dachnowski-Stokes indicates a deposit similar to that described in the present bulletin, but gives some additional information. Cedar and fir stumps were found in situ, and the remains of arrow grass and rhizomes of water lilies were found embedded in coarsely fibrous

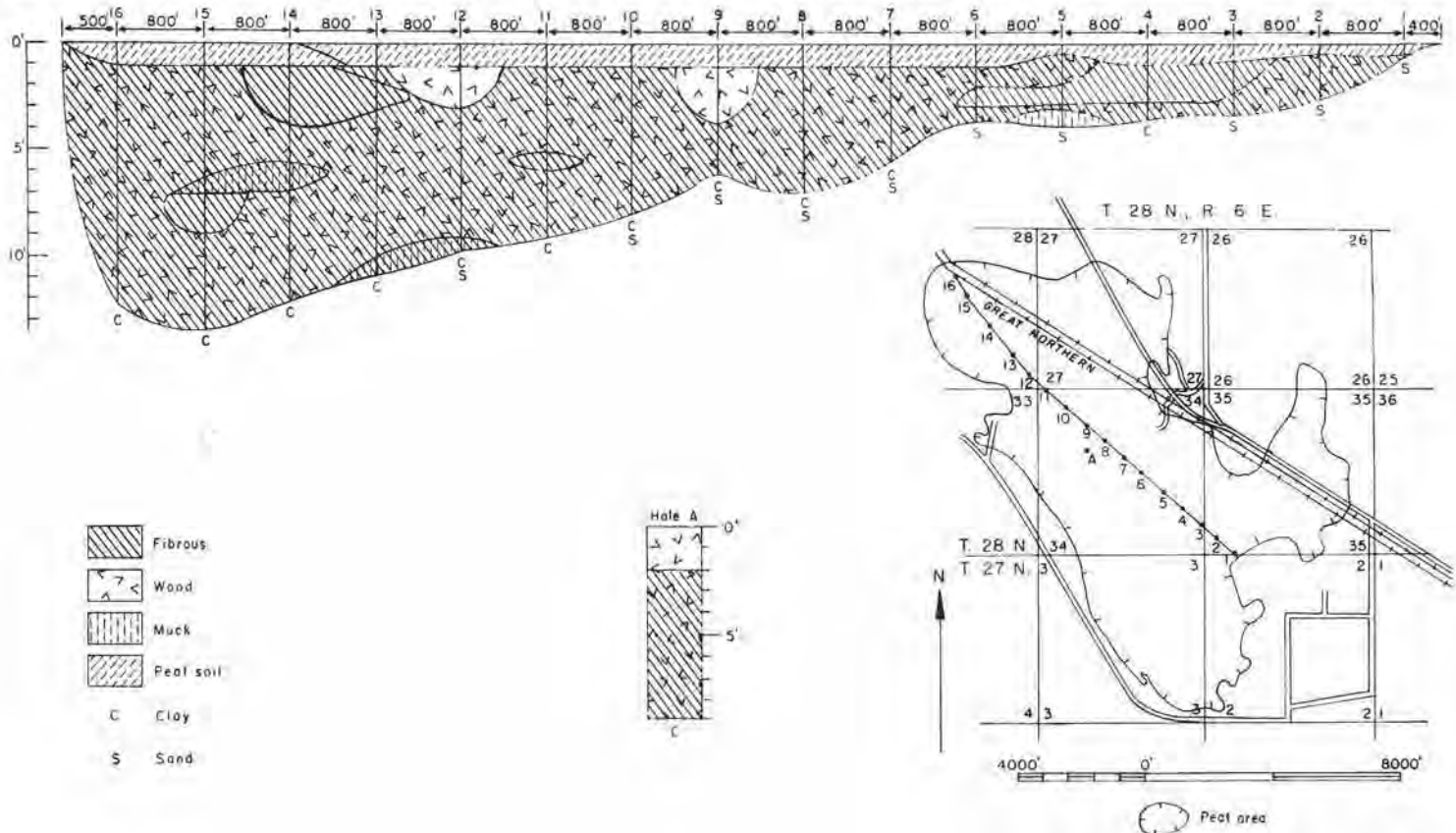

FIGURE 175.—Map, profile, and graphic log of a hole in Frye peat area (1,975 acres). Map adapted from U. S. Department of Agriculture soil map of Snohomish County.

and matted tule-reed peat. He also made borings in the SW $\frac{1}{4}$ sec. 27, where he found 6 inches of cultivated organic soil and 30 inches of sedge muck, under which was blue clay.

Snohomish Valley peat area

The Snohomish Valley peat area (920 acres) is in secs. 5, 8, 9, 15, 16, 21, 22, and 23, T. 28 N., R. 5 E. Its northwestern end is about 1 mile south of Everett, and it extends about 4 miles in a southeasterly direction, but it is not continuous (map, fig. 176). The main body, containing an "island" of hard land, is irregular in shape and is almost 3 $\frac{1}{2}$ miles long. It is mapped on the soil map of Snohomish County (Anderson et al., 1947) as Mukilteo peat. The small area just north of this is also mapped as Mukilteo peat, and the larger one just north of it is mapped as Rifle peat, shallow phase.

The topography of the region is shown on the Everett quadrangle. None of the peat has an elevation of more than 25 feet above sea level. It lies southwest of the Snohomish River but does not extend to the river. The peat is at the extreme southwestern border of the valley, and the land bordering this deposit rises abruptly to an elevation of more than 300 feet. Aggrading by the river has built up the land near its channel; this action has left depressions near the border of the valley, and in these the peat has been deposited. The deepest peat in both profiles (fig. 176) is near the margin of the valley. A road

extends along the south side of the river, and another is on the hard land near the southwestern border of the peat.

The peat is drained by laterals and several ditches to the Snohomish River. Profile A crosses the main ditch between holes 4 and 5 near a lateral. Profile B crosses the ditch just south of hole 2.

In profile A, holes 1, 2, and 3 are in waste land on which willows, hardhack, rushes, knotweed, water celery, mint, and buttercups grow. Hole 4 is in a pasture in which the vegetation consists mainly of reed canary grass. Holes 5 and 6 are in a hayfield in which reed canary grass and other grasses grow.

The deposit shown in this profile consists mainly of fibrous peat and muck, but there is some woody peat and some clay. Marsh gas (methane) was found in hole 2. The fibrous peat is brown to dark brown, and some of it is disintegrated. The muck varies in color from gray to brown, and some is watery. The woody peat is brown. The clay is gray to gray brown. The deposit rests on gray silty clay and fine sand. The peat is strongly acidic (pH 5.3 to 5.5).

In profile B, hole 1 is in waste land on which rushes, scouring rushes, knotweeds, and skunk cabbage grow. Holes 2, 3, 5, 6, and 7 are in pastures in which some weeds grow with the grasses. Holes 4, 8, and 9 are in a hayfield.

The profile shows mostly woody peat, fibrous peat, and mixtures of the two. Sedimentary peat occurs mixed with

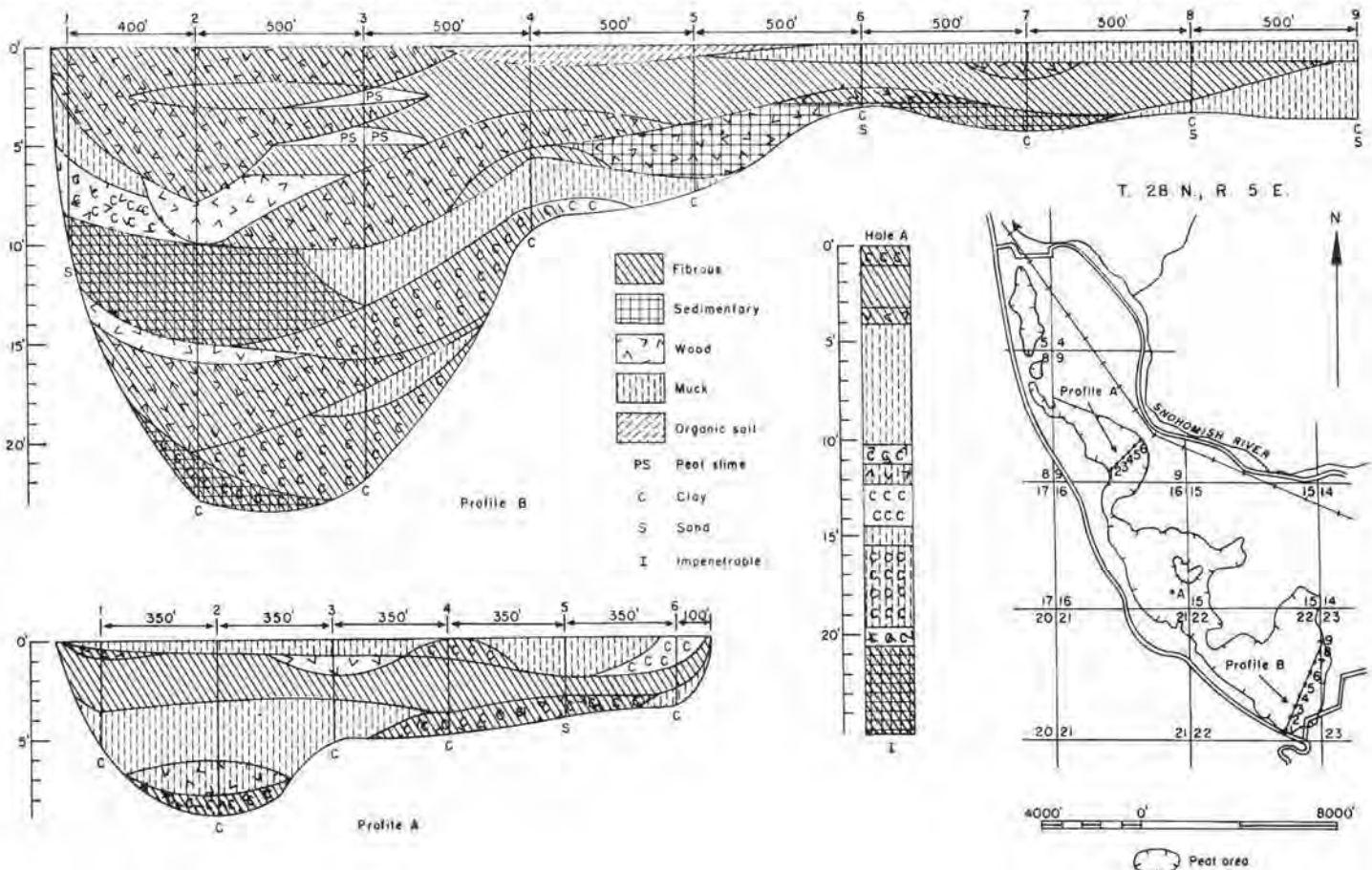

FIGURE 176.—Map, profiles, and graphic log of a hole in Snohomish Valley peat area (920 acres). Map adapted from U. S. Department of Agriculture soil map of Snohomish County.

fibrous peat in two places, with woody peat in another, and with fibrous peat and clay in another. In this profile most of the peat of the various kinds is brown to dark brown. Much of the fibrous peat is disintegrated, and some of it is compact.

Marsh gas (methane) was found in two holes. The peat is strongly acidic (pH 5.0 to 5.5). The deposit rests on gray clay and sand. The clay at the bottom of hole 7 contains some silt.

One hole in the SE $\frac{1}{4}$ sec. 16 near the "island" of hard land shows 24 $\frac{1}{2}$ feet of fibrous peat, muck, sedimentary peat, woody peat, and clay, whose physical properties are similar to those of the same materials shown in the profiles. The bottom of the deposit was not reached because the mixture of fibrous and sedimentary peat at the bottom of the hole was too compact to be penetrated deeper. The hole is in waste land, on which the vegetation consists of rushes, smartweed, and fireweed.

Dachnowski-Stokes (1936) made borings in sec. 22 near the intersection of Marsh road and John Davis road "in an area of peat lands parts of which are used for hay and pasture, potatoes and corn." He found sedge peat, muck, sedimentary peat, and fibrous-sedimentary peat. He states that, "Below a depth of 200 inches in this part of the peat area [the material] largely represents clayey organic sediments that accumulated in an open lake."

Ebey Island peat areas

The seven peat areas in Ebey Island shown on the soil map of Snohomish County (Anderson et al., 1947) are in

secs. 15, 16, 21, 22, 26, 27, 28, 33, 34, and 35, T. 29 N., R. 5 E. This island is bounded by the Snohomish River, Ebey Slough, and a short slough which connects the two near the mouth of the river. Several sloughs, the largest of which are Union Slough and Steamboat Slough, extend across parts of the island, and some sluggish streams flow into these. None of the surface of the island is more than 25 feet above sea level. The island is about 6 miles long from north to south. It is just across the Snohomish River from the eastern boundary of Everett.

U. S. Highway 10A crosses the island from east to west, much of it on a trestle, and parallel to it on the south side is the pipeline which carries the water for the city of Everett. Both of these cross areas I and II.

Four of the seven Ebey Island peat areas were investigated. They are marked I, II, III, and IV on the map (fig. 177). Their total area is 932 acres. Areas I, III, and IV are mapped as Mukilteo peat. No symbol appears on area II, but the inference from the character of the area and the map color would be that it is also mainly Mukilteo peat. The southern part of it is mapped as marsh.

Much of these four areas is waste land. Some of it is swamp forest, some is brushy swamp, and some of it is open marsh characterized by cattails and other marsh plants. Water stands on some of it. Such digging as was done revealed mostly muck at the surface.

Hole 1 is in area I in sec. 28 close to the north line. It is just south of U. S. Highway 10A and just east of the blacktop road that extends south on the center line of the section. The vegetation in the vicinity of the hole consists of hardhack and cattails. The hole shows 26 $\frac{1}{2}$

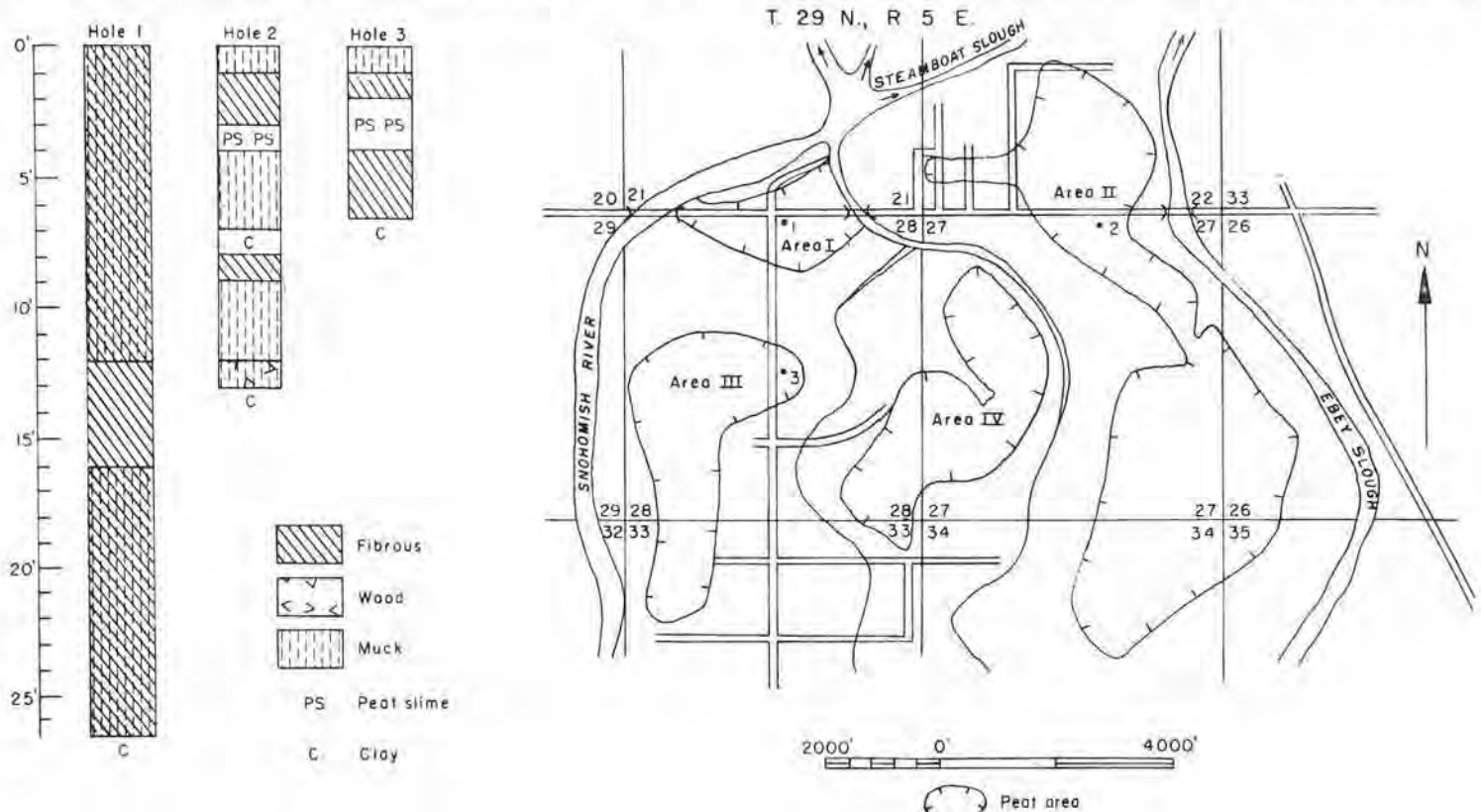

FIGURE 177.—Map and graphic logs of three holes in Ebey Island peat areas (932 acres). Map adapted from U. S. Department of Agriculture soil map of Snohomish County.

feet of organic matter resting on blue clay (fig. 177). The material from the surface to the 12-foot depth and from the 16-foot depth to the bottom is a mixture of muck and fibrous peat in which the former is much more abundant than the latter. The color of the mixture varies from light brown to gray brown. The material from the 12-foot to the 16-foot level is dark-brown wet fibrous peat which contains a large amount of marsh gas.

Hole 2 is in area II, close to the north border of sec. 27, about 250 feet east of the middle of the north line of the section. It is between U. S. Highway 10A and the pipeline. The vegetation in the vicinity is hardhack.

The organic matter is 13 feet deep, and it rests on gray clay. The deposit (fig. 177) consists of muck, fibrous peat, woody peat, peat slime, and gray clay. The muck varies from gray to dark gray to brown through dark brown to black, and from wet to watery. The fibrous peat is coarse, dark brown, and wet.

Hole 3 is in area III, approximately at the center of sec. 28, about 25 feet east of the blacktop road that extends south along the center line of the section. The vegetation in the vicinity is composed of willow, cottonwood, hardhack, and cattails. The deposit (fig. 177) consists of muck, fibrous peat, and peat slime, and is 6½ feet deep. It was noted that when trucks passed on the road there was no shaking of the surface at the hole such as occurs on deep peat. The fibrous peat is brown and decomposed. It contains much marsh gas. Under the fibrous peat is 6 inches of gray clay and then brown muck and particles of wood.

No digging or boring was done in area IV.

Lake Cassidy-Lake Martha peat area

The Lake Cassidy-Lake Martha peat area (623 acres) is in secs. 13, 24, and 25, T. 30 N., R. 5 E.; secs. 19, 30, and 31, T. 30 N., R. 6 E.; and sec. 6, T. 29 N., R. 6 E., about 3 miles east of Marysville and about 5 miles northeast of Everett. It surrounds both lakes (map, fig. 178). Lake Cassidy is reached by a county road, and Lake Martha, by an unimproved road along the Skagit power line of the Seattle city light system. The elevation of the peat is approximately 320 feet above sea level (Marysville quadrangle), and the wooded slopes to the east and west are comparatively gentle. A stream flows south from Lake Cassidy across the peat to Pilchuck Creek. Most of the area surrounding the peat is mapped on the soil map of Snohomish County (Anderson et al., 1947) as Alderwood gravelly loam and Alderwood gravelly sandy loam.

The peat is mapped as Rifle, Greenwood, and Mukilteo peat. The main area is Rifle peat. There is Greenwood peat along the south shore of Lake Cassidy and also along the north and most of the west shore. A Greenwood peat area also borders the north shore of Lake Martha. There is Mukilteo peat at the extreme south end of the area in sec. 6.

Profile A (2,300 feet long) extends from west to east just south of Lake Cassidy (map, fig. 178). It extends a total of 1,350 feet through swamp forest, 100 feet through fir forest on hard land, and 850 feet across sphagnum bog. The swamp forest, however, is in four separate areas and the sphagnum bog is in two areas.

The first, second, and fourth of the swamp forest areas are coniferous forest with some deciduous trees, under which is an undergrowth of shrubs and a partial ground cover of herbaceous swamp plants. The third area of swamp forest is very wet, and there is some standing water on it. The trees are willow, crab apple, dogwood, and aspen. Parts of both of the sphagnum areas have been burned, and bracken fern, velvet grass, fireweed, and other weeds are now common. There are also patches of pigeon wheat moss and a liverwort (*Marchantia*) on the burned areas. Where the sphagnum bog has not been burned it has the usual flora of bog herbs and shrubs. There are some small western birch trees in the sphagnum bog. This species is usually found north (Skagit Valley and northward) and is rare this far south. The usual species of birch in bogs of Snohomish and King Counties is the peat-bog birch.

The deposit shown in this profile (fig. 178) consists of sphagnum peat, fibrous peat, woody peat, diatomite, muck, sedimentary peat, and various mixtures. Any one mixture comprises only two of these, and each of the materials except sphagnum is present in one or more mixtures. The sphagnum peat is brown, and it varies from raw to disintegrated. The fibrous peat is light brown to dark brown and is raw to decomposed. Some of it is watery. The woody peat is brown to black. The mixture of woody peat and fibrous peat in hole 1 is compact. The diatomite occurs only in a mixture with sedimentary peat. The sedimentary peat is olive to olive green. The pumicite is brown in holes 2 and 6 but is white in holes 4 and 5. The layer is ½ to 1 inch thick. The deposit rests on clay, sand, and gravel. The clay is gray to blue, and the sand is gray.

Profile B (1,375 feet long) extends northward from the north shore of Lake Martha to hard land. Hole 1 is at the margin of the lake, in a sphagnum bog which has the usual flora of bog shrubs and herbaceous plants and some swamp plants. There are also some small lodgepole pine trees and some western birch trees.

About 300 feet north of hole 1 the sphagnum bog merges into a very dense swamp forest in which there are many logs and an extremely dense undergrowth of shrubs. The trees are hemlock, cedar, lodgepole pine, alder, crab apple, and western birch. The shrubs are hardhack, Labrador tea, salal, and red huckleberry. Bracken fern is also present. The mat of old down hardhack is so dense that the only way to get through the forest is to walk on the mat.

About 900 feet north of hole 1 this forest merges into a very dense growth of hardhack with few living trees but some down trees, mostly charred by fire. Skunk cabbage is abundant. The profile ends just across the road from a steel tower of the Skagit power line of the Seattle city light system. The vegetation on the margin of the peat is composed of hardhack and cattails.

The deposit (fig. 178) consists of sphagnum peat, fibrous peat, woody peat, sedimentary peat, and mixtures of some of these. The sphagnum is brown and watery. It varies from raw to partially disintegrated. The fibrous peat is mostly dark brown. The sedimentary peat is mostly olive, but some of it is brown. The sphagnum peat

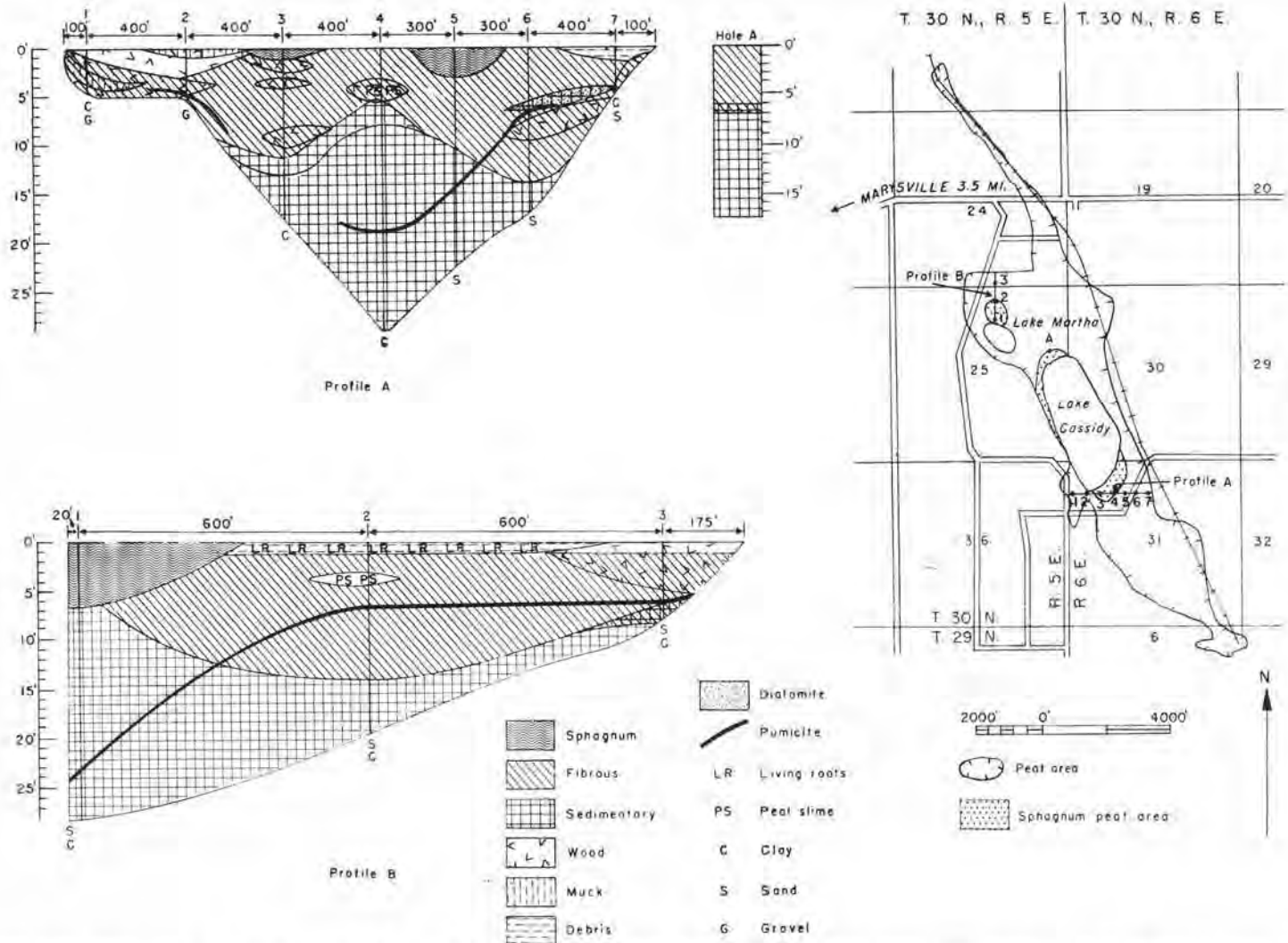

FIGURE 178.—Map, profiles, and graphic log of a hole in Lake Cassidy-Lake Martha peat area (623 acres). Map adapted from U. S. Department of Agriculture soil map of Snohomish County.

is strongly acidic (pH 3.8). The fibrous peat is also strongly acidic (pH 3.8 to 4.5). The sedimentary peat is strongly acidic (pH 3.8) to rather weakly acidic (pH 5.2). The pH of the water of the lake is 5.0.

There is only a trace of white pumicite in hole 1, but there may be more scattered in the peat. At hole 2 the layer is white and is 1 inch thick. At hole 3 the 1-inch layer is yellow at the top and almost white at the bottom. The deposit rests on clay (gray to blue) and fine sand.

In addition to the two profiles described above, a single hole was bored 300 feet north of the north shore of Lake Cassidy. The area was burned some years ago, and old partially burned snags are numerous. The living trees are willows and young alders. The shrubs are hardhack, black twinberry and salmon berry. Fireweed and bracken fern are common.

The hole shows 6 feet of fibrous peat which varies from light brown to dark brown and from rather raw to disintegrated. Under this is 1 foot of an olive-brown mixture of fibrous peat and sedimentary peat. The remaining 10½ feet of the deposit consists of olive to olive-brown

sedimentary peat which rests on gray sand and gravel. No pumicite was found in this hole.

There are some gardens on the peat near profile A, and some sphagnum (peat moss) has been removed and marketed. The sphagnum north of Lake Martha is suitable for agricultural or horticultural use, but it is rather watery.

Thomas Lake peat area

The Thomas Lake peat area (280 acres) is in secs. 28, 29, 32, and 33, T. 28 N., R. 5 E., and sec. 4, T. 27 N., R. 5 E., about 7 miles south of Everett. It entirely surrounds Thomas Lake and borders most of the shore of Ruggs (Lees) Lake. The topography of the region is shown on the Everett quadrangle. The elevation of the peat is between 375 and 400 feet above sea level, and the surrounding slopes are comparatively gentle. There is some drainage across the peat from both lakes by ditches to a creek which flows into North Creek, which in turn flows into the Sammamish River in King County.

On the soil map of Snohomish County (Anderson et al., 1947) a large part of the area is mapped as Mukilteo

peat. There are also two areas of Greenwood peat—one surrounding Thomas Lake and one bordering the west shore of Ruggs Lake. There are two areas of Rifle peat—one in an arm which projects southward into sec. 4 and the other bordering an "island" of hard land in the northern part of the peat area. There is also an area of Carbondale muck, shallow phase, in the northern part of the area.

Besides these there are three small areas of Greenwood peat nearby which are shown on the soil map of Snohomish County. One of these is in sec. 32, south of the west arm of the main area. This is also shown in figure 179. The other two lie close together in sec. 28, just east of the northern part of the main area.

Much of the soil bordering the main peat area is mapped as Alderwood gravelly loam and Alderwood gravelly sandy loam.

The profile (3,440 feet long) extends from south to north, 25 feet east of and parallel to the county road which extends between secs. 32 and 33. All borings ex-

cept hole 8 were made in places where the natural surface of the peat had not been disturbed. The vegetation at hole 1 consists mostly of sedges. Holes 2 and 3 are in a sphagnum bog. The plants in the vicinity of holes 4, 5, and 6 are Labrador tea and hardhack, and at hole 7 they are willow and hardhack. Hole 8 is in the waste land of an abandoned field.

Brown sphagnum peat at or near the surface extends through about 1,900 feet of the profile (fig. 179). Some of it is raw, but much of it is somewhat disintegrated, and some is decomposed. The fibrous peat is brown, and much of it is wet. It varies from coarse to fine, and some of it is decomposed. The sedimentary peat is brown to olive green. Yellow pumicite forms a layer 1/2 inch to 2 inches thick.

Three other holes show additional details of this deposit (fig. 179). Hole A is 170 feet north and 50 feet east of hole 7 of the profile, in a place where peat was being removed in 1950 for use on the Everett golf course. It shows 9 feet of light-brown to brown wet fibrous peat, mostly decomposed, and 2 feet of olive sedimentary peat

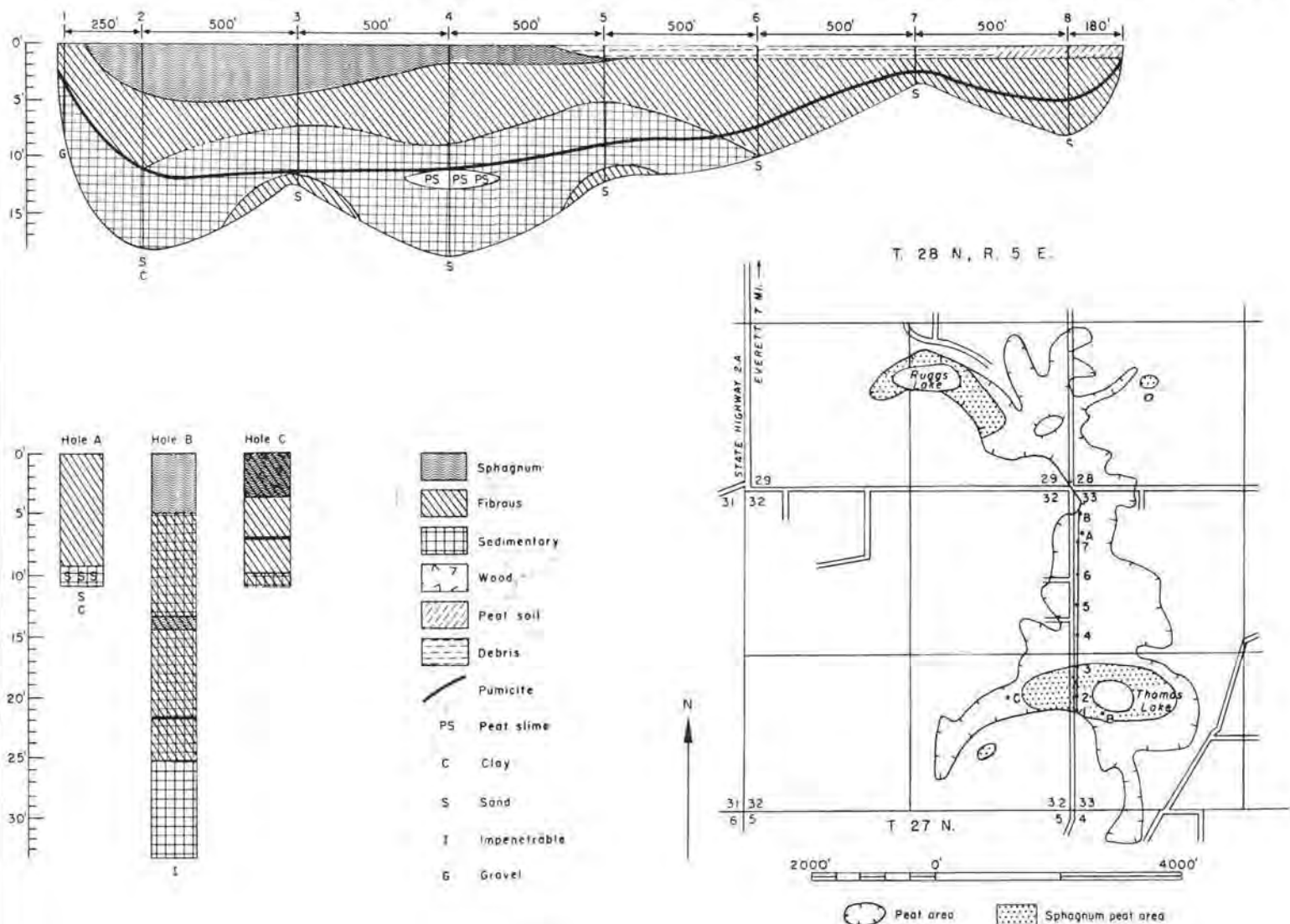

FIGURE 179.—Map, profile, and graphic logs of three holes in Thomas Lake peat area (280 acres). Map adapted from U. S. Department of Agriculture soil map of Snohomish County.

mixed with sand. Hole B is 60 feet south of the south shore of Thomas Lake. It shows 4 feet 10 inches of raw sphagnum which is watery at the bottom of the layer. Under this is a 2-inch layer of dark-brown watery sedimentary peat. Below this is a dark-brown wet mixture of fibrous peat and sedimentary peat continuous to the 24½-foot level, with the exception of a 1-foot layer of mixed sphagnum and fibrous peat at the 13- to 14-foot level. Below this is olive-green sedimentary peat, which at the 32½-foot depth is too compact to be penetrated farther with the peat borer. White pumicite forms a layer ½ inch thick at the 21-foot depth. Hole C is in the southwest arm of the area, in sec. 32. The peat in the vicinity of this hole has been scalped, and in 1950 peat was being removed and marketed by L. D. Fairfield, 6604 Highway 99, Everett. At the surface it shows 1 foot of coarse reddish-brown fibrous peat with some sphagnum. Under this is a 2½-foot layer of similar composition but mixed with heath twigs and leaves. Under this is a 6½-foot layer of brown decomposed fibrous peat. The bottom layer, 1 foot thick, is an olive-colored mixture of sedimentary peat and fibrous peat. There is a 2-inch layer of yellow pumicite at the 7-foot depth.

In hole B the sphagnum is strongly acidic (pH 3.2 to 3.8), and the sedimentary peat is rather strongly acidic (pH 4.3 to 4.8). The fibrous peat in hole 5 of the profile is strongly acidic (pH 3.5).

The Thomas Lake deposit rests mostly on coarse sand, which varies in color from gray to greenish blue and in some places is mixed with blue to greenish-gray clay.

Some peat was being removed and marketed from the area east of Thomas Lake in 1950. The marketing of peat removed from near hole A and hole C has already been mentioned. The commercial possibilities of the sphagnum surrounding Thomas Lake merit investigation.

The two small areas (total 10 acres) in sec. 28, east of

the northern part of the Thomas Lake peat area, are sphagnum bogs which have been modified by clearing and some burning. The vegetation is mostly hardhack, but some Labrador tea and other bog plants still remain. There is some dead *Sphagnum*. The owner of the south area stated that he had removed samples of peat down to the 12-foot depth.

Robe peat area No. 1

Robe peat area No. 1 (222 acres) is in sec 8, T. 30 N., R. 8 E., about 1 mile east of Robe, 1 mile west of Verlot Ranger Station, and about 7 miles east of Granite Falls. The mountain loop highway (Granite Falls-Barlow Pass-Darrington-Arlington) passes between the peat and the Stillaguamish River. The abandoned grade of the Monte Cristo branch of the Northern Pacific Railway is south of the river.

The peat lies in the flat valley of the Stillaguamish River at an elevation of between 900 and 1,000 feet above sea level. The 1,000-foot contour is close to the north side of the peat, and the 900-foot contour is close to the south side (Stillaguamish quadrangle). The strip of hard land, a few hundred feet wide, between the south side of the peat and the river is relatively flat. There is some drainage by creeks from the peat to the river. The river valley is less than 1 mile wide, and the land rises abruptly to an elevation of several thousand feet on both the north and the south side. The alluvium in the flat valley is sandy and gravelly. The depression in which the peat lies probably represents an abandoned channel of the Stillaguamish River.

The average annual temperature at Granite Falls as reported in 1941 is 59.41° F.

On the Stillaguamish quadrangle an extensive marsh is shown in secs. 6, 7, 8, and 9 which includes the location of Robe peat area No. 1 and also Robe No. 2. On

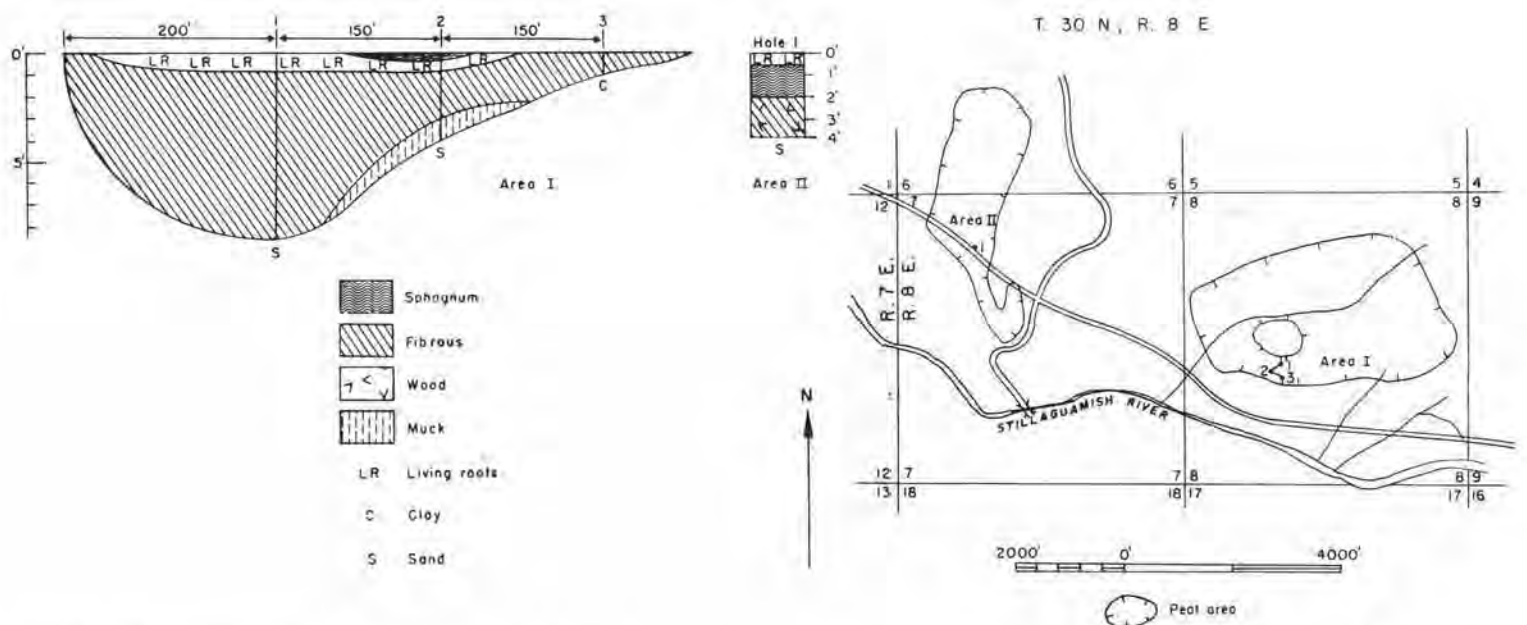

FIGURE 180.—Map, profile, and graphic log of a hole in Robe peat areas (222 acres and 121 acres). Map adapted from U. S. Department of Agriculture soil map of Snohomish County.

the soil map of Snohomish County (Anderson et al., 1947) the Robe peat area is mapped as Mukilteo peat, Greenwood peat, and Rifle peat, with an "island" of hard land in the Mukilteo peat. The locations of the peat and the "island" are shown on the map in figure 180.

A wet area of about 15 acres which lies south of the "island" of hard land has a mixed flora of swamp plants, bog plants, trees, and shrubs. The swamp species include cattails, skunk cabbage, monkey flower, sedge, and a species of scouring rush which commonly grows in shallow water. The bog species include buckbean, *Sanguisorba*, orchids, peat moss, cranberry, bog laurel, and Labrador tea. The trees are willow, alder, hemlock, and spruce. The brush is mostly hardhack.

The profile of three holes extends from north to south, but hole 2 is 200 feet west of the line from hole 1 to hole 3. The material shown in the profile (fig. 180) is mostly fibrous peat. There is some accumulation of living *Sphagnum* and also some muck. The fibrous peat is brown to dark brown, wet to watery, and mostly decomposed. The muck is brown. The deposit rests on sand (dark-gray to greenish-gray) and blue clay.

In the field work on which this bulletin is based, no detailed examination was made of the northern part of the area shown as peat on the soil map.

Robe peat area No. 2

Robe peat area No. 2 (121 acres) is in secs. 6 and 7, T. 30 N., R. 8 E., about 1 mile west of Robe peat area No. 1. The physiographic features of the hard land surrounding this area are similar to those described for area No. 1. On the soil map of Snohomish County (Anderson et al., 1947) two streams are shown flowing into area No. 1, and one stream is shown flowing from area No. 1 to area No. 2. On the soil map the peat in this area is mapped as Greenwood, Mukilteo, and Rifle peat, shallow phase. The loop highway crosses the area (map, fig. 180).

One hole in a hardhack area 50 feet north of the highway shows 4 feet of organic matter resting on greenish-gray sand. The upper 6 inches consists of living roots and surface debris. The next 18 inches is wet brown sphagnum peat. The lower 2 feet is brown wet decomposed fibrous peat mixed with woody peat.

Crystal Lake-Little Lake peat area

The Crystal Lake-Little Lake peat area (133 acres, including 57 acres of sphagnum) is in secs. 25 and 36, T. 27 N., R. 5 E., about 3 miles northeast of Woodinville, less than 1 mile south of Maltby, and about 7 airline miles northeast of the north end of Lake Washington. The peat entirely surrounds Little Lake and borders a large part of the shore of Crystal Lake (map, fig. 181). The location of the lakes and the topography of the region are shown on the Everett quadrangle. The elevation of the peat is about 335 feet above sea level. Daniels Creek flows south from Crystal Lake to Cottage Lake in King County. The peat area is mapped as marsh.

Dead-end roads extend to the vicinity of the peat. Practically the entire area, including both lakes, is owned by the Crystal Lake Community Club, Route 1, Woodinville. The residences of club members are on the west

shore of Crystal Lake. A canal 6 feet wide has been excavated in the peat from Crystal Lake to Little Lake.

On the soil map of Snohomish County (Anderson et al., 1947) the sphagnum area surrounding Little Lake is mapped as Greenwood peat. The outer part of the area, including part of the narrow strip bordering Crystal Lake, is mapped as Rifle peat. Some Mukilteo peat is shown bordering the south shore of Crystal Lake.

The sphagnum bog has the usual vegetation of bog shrubs and herbaceous plants. Living *Sphagnum* is abundant. Water lilies are abundant in the margin of the lake, and they are clogging the canal. The trees on the bog are practically all lodgepole pine. They are numerous in some places but are not large. The Rifle peat at the border of the bog is mostly covered with deciduous trees, but there are some conifers. The undergrowth consists of hardhack and other shrubs.

The kinds of peat in profile A are shown in figure 181. The layer of sphagnum is comparatively deep. It is brown and mostly raw. It is wet, and some of it is watery. The fibrous peat is brown and wet. Some of it is rather raw, and some is disintegrated. The sedimentary peat is olive to olive brown. The mineral materials at the bottom of hole 1 are fine sand and pea-size gravel. In hole 2 the sedimentary peat at the depth of 30 feet is too compact to be penetrated farther. White pumicite forms a layer $\frac{1}{2}$ inch thick at the 28-foot depth.

The peat is strongly acidic (sphagnum, pH 4.3; fibrous, pH 3.8 to 4.4; sedimentary, pH 4.5).

Profile B extends along the canal from Little Lake to Crystal Lake. The materials in it are similar to those in profile A. The large amount of peat slime present there is to be expected in peat which lies between two lakes. The rock encountered at the bottom of hole 2 is probably a boulder.

This is a large deposit of sphagnum moss—probably the largest in the state.

Silvana peat area

The Silvana peat area (127 acres) is in secs. 10, 11, 14, and 15, T. 31 N., R. 4 E., $1\frac{1}{2}$ miles southwest of Silvana and about 6 miles west of Arlington. Its elevation is about 175 feet above sea level (Stanwood quadrangle). The slopes surrounding it are comparatively gentle. It is accessible by road.

On the soil map of Snohomish County (Anderson et al., 1947) it is mapped as Mukilteo peat with Carbondale muck, shallow phase, bordering it on the southeast.

The area was investigated by walking over it and observing the banks of drainage ditches and the borders of burned areas near which fires were burning at the time. The peat is less than 3 feet deep near the margin but is more than 4 feet deep near the center. It is mostly woody peat mixed with some fibrous peat and diatomite. Formerly there was a thin cover of *Sphagnum* moss on the surface, but most of it has been destroyed by fire. The fires which were burning at the time the peat was inspected were set for the purpose of burning brush. They had burned into the peat to a depth of at least 1 foot, perhaps more.

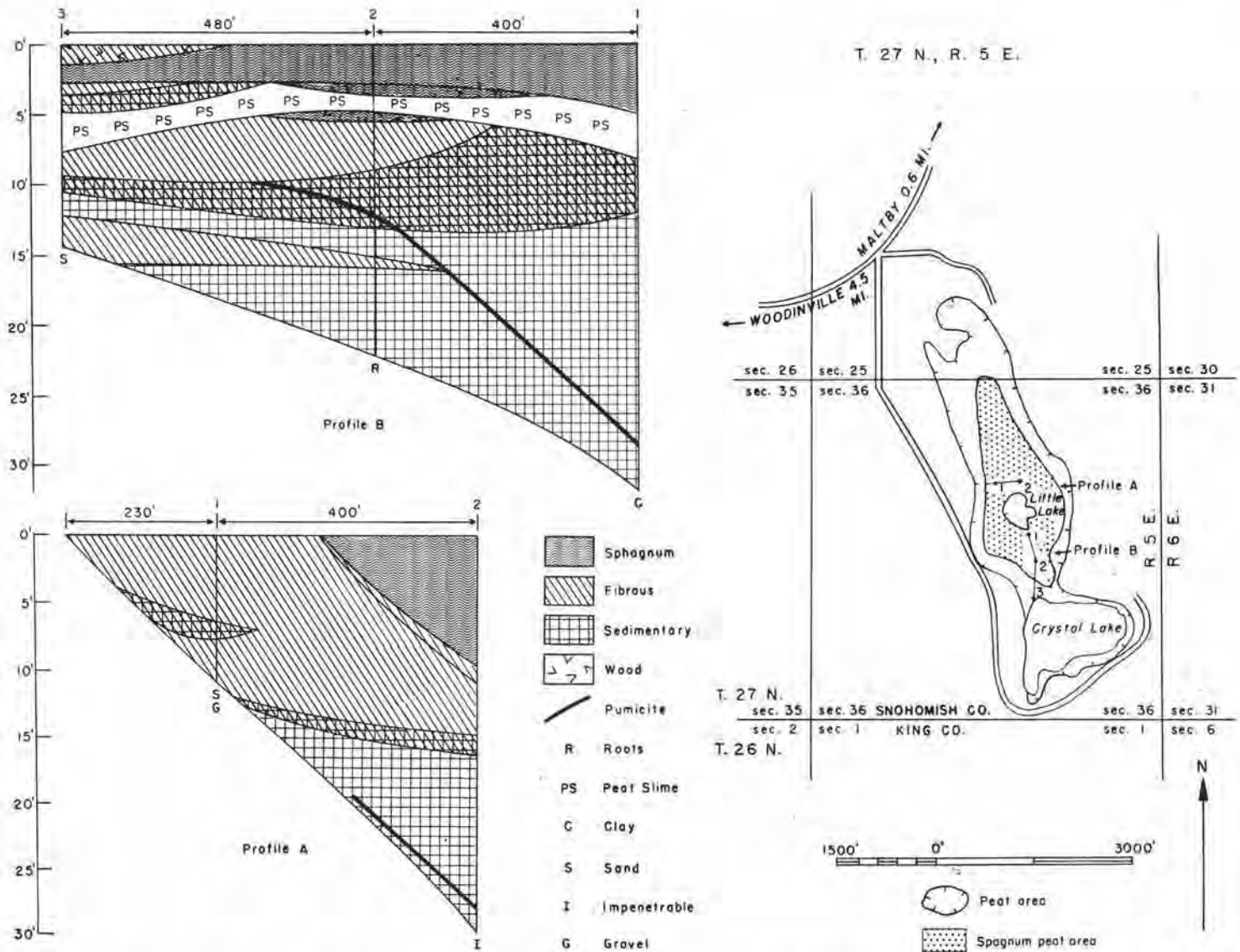

FIGURE 181.—Map and profiles of Crystal Lake-Little Lake peat area (133 acres, including 57 acres of sphagnum). Map adapted from U. S. Department of Agriculture soil map of Snohomish County.

Kirk Lake peat area

The Kirk Lake peat area (100 acres) is in sec. 23, T. 32 N., R. 9 E., about three-quarters of a mile southwest of Darrington. Both the town and the peat are between the 500-foot and the 600-foot contours (Stillaguamish quadrangle). The peat lies on an old river terrace, the elevation of which is estimated to be 75 feet higher than that of the town. All the extensive area of sandy and gravelly soils lying north and east of the peat also has an elevation of between 500 and 600 feet above sea level.

Although this peat is less than 600 feet above sea level, there are two rivers near it at nearly the same level, and it is almost surrounded by mountains. The Sauk River, originating in a mountainous region, flows north to the Skagit River and passes about 1 mile east of the peat. Just east of the river the land rises abruptly to an elevation of 3,493 feet (Gold Mountain). The North Fork

Stillaguamish River flows south and then west about 2 miles northwest of the peat. Within 2 miles north of the river the land rises to an elevation of 2,654 feet. There are also mountains to the south of the peat. White Horse Mountain, 4 miles southwest, has an elevation of 6,820 feet. Squire Creek, which originates in the high mountains south of White Horse, flows north to the North Fork Stillaguamish and passes about 1 mile west of the peat. Obviously, the courses of the rivers in this area have been greatly altered, probably due to continental glacial blockades in Pleistocene time. A byproduct of these stream-channel changes is the terrace and the depression in its surface in which lie Kirk Lake and the peat.

Data on weather at Darrington, as recorded at the cooperative station of the U. S. Weather Bureau and the U. S. Forest Service, show the following:

Precipitation:

Average annual	75.95 inches
Maximum average for one month (December)	13.65 inches
Minimum average for one month (August)	1.16 inches

Temperature:

Average annual	48.7° F.
Maximum average for one month (July and August)	62.6° F.
Minimum average for one month (January)	34.1° F.

Snowfall:

Average annual	39.9 inches
Maximum average for one month (January)	13.6 inches

The area is mapped mainly as Greenwood peat on the soil map of Snohomish County (Anderson et al., 1947), but there is some Carbondale muck, shallow phase, at the south end.

Much of this peat area is covered with bog forest, but there is a sphagnum bog around the lake, and the north arm has a dense growth of hardhack with grass around the margin.

Most of the forest is a pure stand of lodgepole pine. In the southern part the forest is very dense and the trees are relatively large for this species (up to 2 feet in diameter), the brushy undergrowth is dense, and skunk cabbage is abundant on the extremely wet surface. This is climax forest, and if it is not disturbed by clearing or burning, it will remain as it is for many years. It is not possible to say what kind of plant community will occupy the area when the trees grow old, die, and decay. Farther north the trees are smaller and the forest in some places is less dense. *Sphagnum* grows on the surface.

The sphagnum bog is very wet, and water stands at the surface in many places. There is no outlet to the lake which it borders. In the bog at the margin of the lake there is a fringe of buckbean and purple marshlocks, but the lake is several feet deep at the margin and the bog is encroaching on it very slowly if at all. There is, however, one transition species from the lake to the bog. This is water lily, which occurs in the lake and also survives in the margin of the bog, where it is rooted deep in muck and only the blades of its leaves are above the *Sphagnum*.

The most abundant shrubs in the bog are Labrador tea and bog laurel. The small prostrate woody vines of the native cranberry are also abundant. Among the numerous

Snow falls in January, February, March, April, November, and December. The average for April is 0.7 inch. Extreme variations in snowfall in January for single years are 46, 43, 5, and 3 inches; and for February, 45.0 and 4.5 inches.

The length of the growing season, as reported in the U. S. Department of Agriculture Yearbook (1941), is 145 days. The length of the growing season at other points in Snohomish County is 219 days at Startup, 213 at Everett, 197 at Monroe, and 179 at Snohomish.

The peat is accessible by roads. A highway leading west from Darrington crosses the northern part of it, and a one-way unimproved road extends south from this road close to the western border of the peat. The location of these roads, the lake, and the seven holes which were bored in the peat are shown on the map (fig. 182).

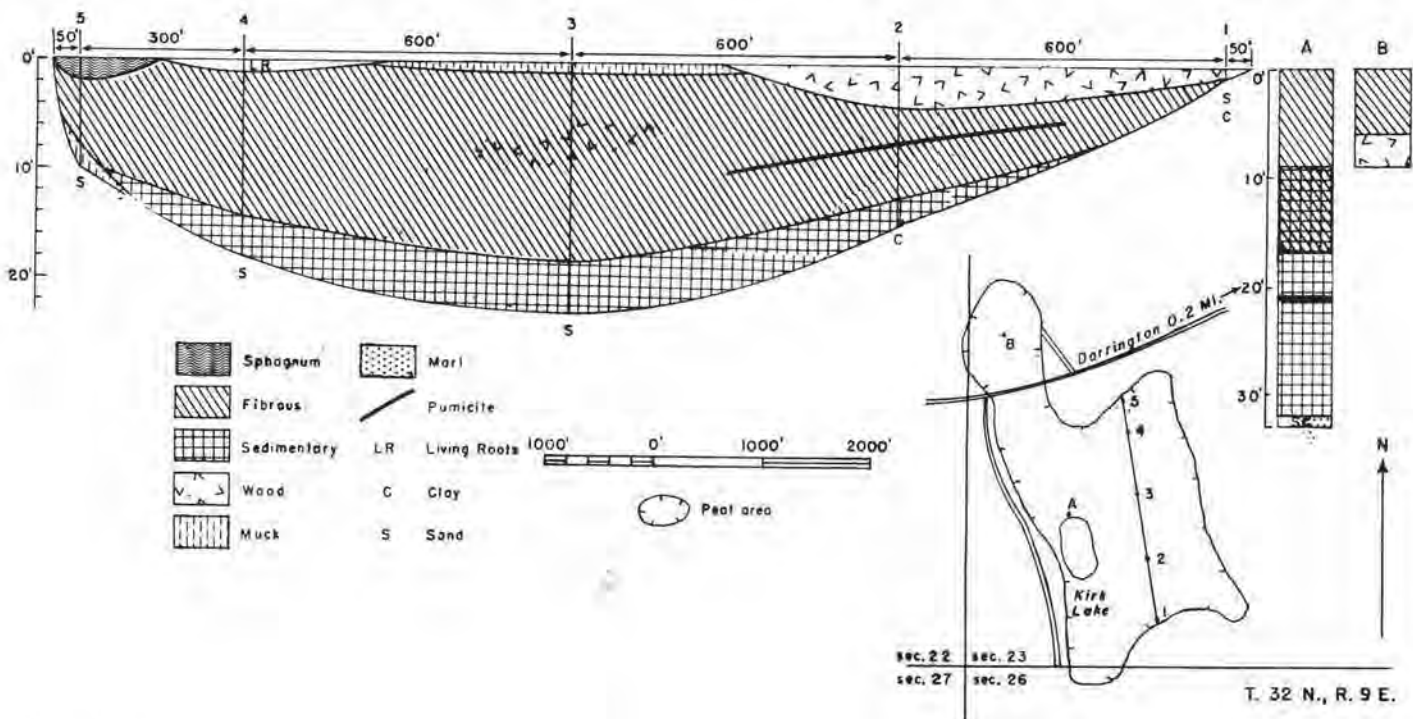

FIGURE 182.—Map, profile, and graphic logs of two holes in Kirk Lake peat area (100 acres). Map adapted from U. S. Department of Agriculture soil map of Snohomish County.

herbaceous species are sundew, bog star flower, skunk cabbage, two small-flowered orchids, and bunchberry (herbaceous dogwood). A large sedge is abundant, and bracken fern up to 4 feet tall occurs in patches. Two species of *Sphagnum* (*S. recurvum* and *S. squarrosum*) are common, and another moss (*Amblystegium*) occurs near the lake.

The transition from the bog to the forest is gradual. The trees in the transition zone are crab apple, cascara, aspen, and scattered white pine. One shrub (black twin-berry) occurs in places.

This bog was inspected by Rigg in 1925, and it was observed then that part of the bog had been burned several years prior to that time.

The profile (2,200 feet long) extends from south to north across the forested part of the area. The material found in it in largest amount (fig. 182) is fibrous peat. Woody peat and sphagnum peat are present at the surface, and a layer of sedimentary peat occurs at the bottom.

The fibrous peat is light brown to dark brown. Most of it is wet, and some is decomposed. The woody peat is wet and varies from light brown to dark brown. The muck is black. The sedimentary peat is olive to brown. Sphagnum is present at hole 5 only. The upper 6 inches is a mixture of sphagnum and pine needles, and the next 6 inches is rather raw brown sphagnum. The material from the 1-foot to the 2-foot level is brown decomposed sphagnum. Pumicite was found in hole 2 only, but it may be present as scattered material in the other holes. In hole 2 it is white, and the layer is only ¼ inch thick. So far as shown in the profile, the deposit rests mainly on gray sand, but there is some bluish-gray clay and some mixture of sand and clay which has a rust-brown color.

Hole A is 10 feet north of the north shore of the lake in the sphagnum bog which has already been described. This hole is considerably deeper than any of the holes of the profile.

The fibrous peat is brown and watery and has needles of coniferous trees mixed with it at the 2- to 5-foot depth. The mixture of fibrous peat and sedimentary peat is watery. The sedimentary peat is olive to brown to dark olive green. It rests on a blue-green mixture of sand and clay which contains traces of marl. A ¼-inch layer of white pumicite occurs at the 21-foot level. The acidity of the peat decreases gradually from rather strongly acidic (pH 4.5) near the surface to weakly acidic (pH 5.8) at the bottom.

Hole B is in a circular area of 10 acres or less which lies north of the road and is connected with the main area by a neck of peat. The central part of the area is covered with a dense growth of hardhack, and the margin, with grasses.

The upper 6 feet of the deposit (fig. 182) is brown decomposed fibrous peat, and the lower 3 feet is brown sedimentary peat which is somewhat mixed with woody peat. The deposit rests on blue-gray sand and clay. The peat is rather strongly acidic (pH 4.5).

Some peat near this hole has been removed and stockpiled for marketing by Merle Boehmer of Darrington.

Paradise Lake peat area No. 2

Paradise Lake peat area No. 2 (99 acres, including 17 acres of sphagnum) is in sec. 32, T. 27 N., R. 6 E., in Snohomish County, and sec. 5, T. 26 N., R. 6 E., in King County. It is about 1½ miles southeast of Maltby and about 6½ miles by road northeast of Woodinville. The airline distance from the north end of Lake Washington in King County is about 9 miles. The Paradise Lake peat area No. 1 is in King County and is described under that heading on p. 87 of this report.

The peat borders the north shore of Paradise Lake, and a stream flows through its entire length to the lake (map, fig. 183). It is over 1 mile long and is about 1,000 feet wide at its widest point. The topography of the region is shown on the Everett quadrangle. The elevation of the peat is about 260 feet above sea level. On the soil map of Snohomish County (Anderson et al., 1947) the sphagnum bog is mapped as Greenwood peat, and the main area is mapped as Mukilteo peat.

Two holes about 350 feet apart in the sphagnum area on the farm owned and occupied by James Fellows show a difference of 28½ feet in depth (fig. 183). Hole 1 is near a farm road. The plants growing in the vicinity are

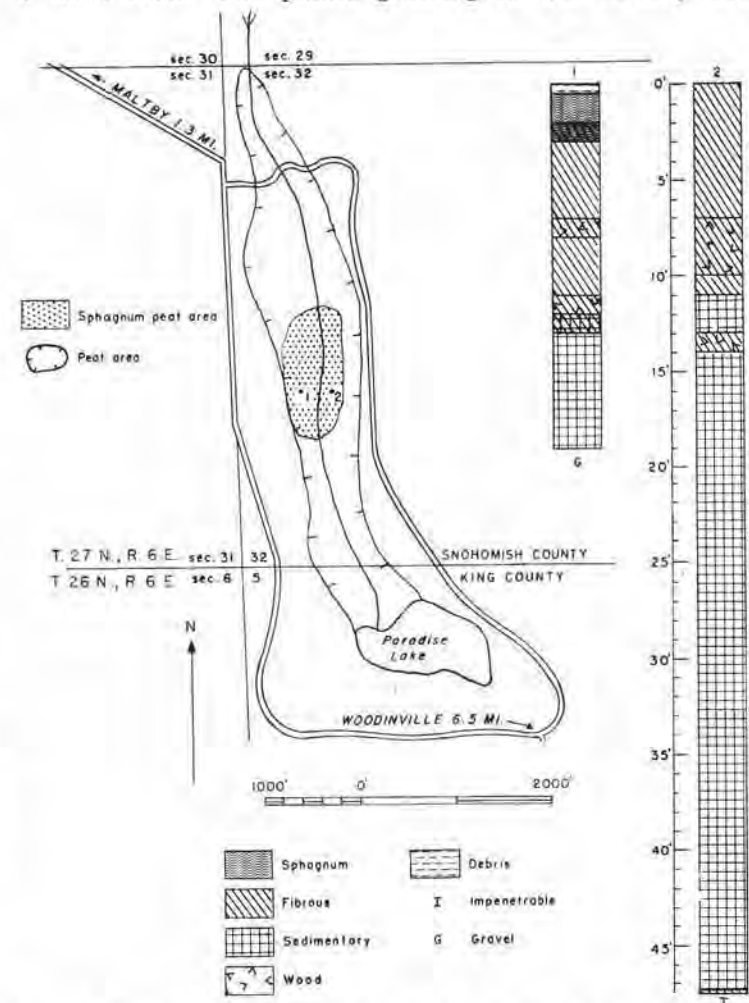

FIGURE 183.—Map and graphic logs of two holes in Paradise Lake peat area No. 2, Snohomish County (99 acres, including 17 acres of sphagnum). Map adapted from U. S. Department of Agriculture soil map of Snohomish County.

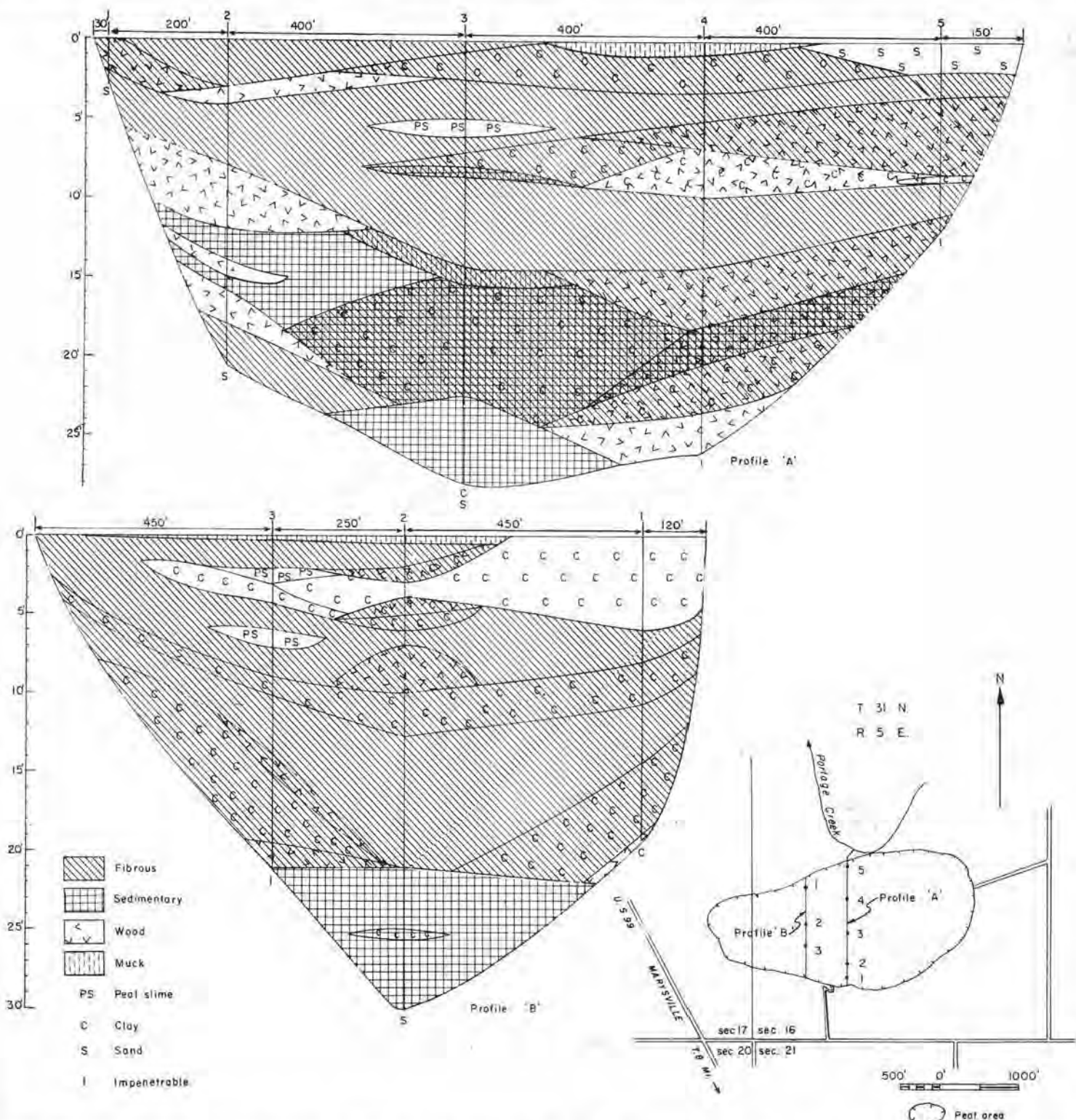

FIGURE 184.—Map and profiles of Portage Creek peat area (97 acres). Map adapted from U. S. Department of Agriculture soil map of Snohomish County and U. S. Army Map Service photomosaic.

Labrador tea, bog laurel, sundew, *Sphagnum*, bracken fern, salal, and crab apple.

The kinds of peat shown in this hole are sphagnum, fibrous, woody, and sedimentary. The sphagnum peat is raw, brown, and strongly acidic (pH 4.0). The fibrous peat is brown and watery. At the 11- to 12-foot level it is

decomposed. The sedimentary peat is olive brown to dark brown and is watery at the bottom. It rests on gravel. The mixture of fibrous peat and sedimentary peat at the 12- to 13-foot level is rather strongly acidic (pH 4.7). Near hole 1 some peat has been removed for local use.

Hole 2 is in a very wet area where water is standing

in places. The owner stated that hay had been mowed there a few years ago. The area is now abandoned, and *Sphagnum* is growing vigorously among the stems of sedges. A hole 1 foot deep, dug with a shovel, filled with water almost immediately.

The characteristics of the various kinds of peat found in hole 2 are similar to those of the same kinds found in hole 1, except that the lower 20 feet of the sedimentary peat is compact. At the depth of 47½ feet it contains traces of white pumicite and is too compact to be penetrated farther with the peat borer.

Portage Creek peat area

The Portage Creek peat area (97 acres) is in secs. 16 and 17, T. 31 N., R. 5 E., about 4 miles southwest of Arlington. It is about ¼ mile east of U. S. Highway 99 about 8 miles north of Marysville. The deposit is accessible by county and private roads. The topography of the region is shown on the Marysville quadrangle. The elevation of the peat is less than 50 feet above sea level. A loop of Portage Creek, a meandering stream which flows into South Slough, is close to the north side of the peat (map, fig. 184). At the southern border of the peat the land rises abruptly about 50 feet.

This peat area is one of several, all similar, occurring near Arlington and lying along the south side of the broad alluvial floor of the Stillaguamish Valley. These areas are in the outer side of abandoned meander loops of the river, and the depressions in which the peat has accumulated owe their origin in part to the aggrading action of the river on its flood plain. The river is now near the north side of the valley about a mile north of the Portage Creek peat area.

Profile A (1,580 feet) extends from south to north along a drainage ditch (fig. 185) which carries clear water with a good current to Portage Creek. It is on the farm owned and operated by John French.

Hole 1 is in a pasture in which grasses, skunk cabbage, and weeds grow. A log 20 feet long is embedded at the surface near the hole. Holes 2 and 3 are in the pasture where common rushes and scouring rushes grow with the pasture grasses. Holes 4 and 5 are in a clover hayfield in which there is some dock and also some other weeds.

The complicated structure of this deposit (fig. 184) indicates several changes in the conditions under which the sedimentary peat, fibrous peat, woody peat, muck, silt, clay, and sand were deposited. Aggrading by the river was probably irregular, and during floods the water probably broke through from time to time on the convex side of curves in the channel, carrying mud and sand out over the valley floor. In this way thin layers of sand and clay became interbedded with the peat as it accumulated.

The layers of sedimentary peat and fibrous peat indicate stable conditions extending over considerable periods of time. The woody peat may have been formed where it lies, but at least some of it may have been formed from trees, shrubs, and broken pieces of wood which were washed in. There is no continuous layer of woody material extending through the entire profile. As logs were found embedded in the peat, some of the borings had to be made a few feet distant from the place first tried. In

one place the borer penetrated 4 inches of rotted wood. The fact that the clay is mostly mixed with fibrous peat or sedimentary peat, or both, emphasizes the complexity of the conditions under which deposition took place. Obviously, the clay, silt, and sand were washed in. The clay at the bottom of holes 1 and 2 is gray, as is also the clay and sand mixture at the bottom of hole 3. The full depth of the peat in holes 4 and 5 is not known, because the material is too compact to be penetrated farther than the depths shown in figure 184.

Most of the peat is some shade of gray or brown. The fibrous peat is mostly disintegrated, and some of it is decomposed. Marsh gas (methane) bubbled up from one hole during the boring. The muck at the surface at hole 4 is gray brown. The peat is weakly acidic (pH 5.3 to 5.7).

Profile B extends along a drainage ditch approximately 500 feet west of profile A. It is on the line between the Jarl Sesby farm and the John French farm. Hole 1 is in a peafield, and holes 2 and 3 are in a hayfield. The materials shown in the profile are similar to those in profile A. Marsh gas bubbled up from holes 2 and 3.



FIGURE 185.—Hand-dug drainage ditch in woody peat on farms of J. Sesby and C. French, 4 miles southwest of Arlington, U. S. Department of Agriculture Soil Conservation Service photo.

Lake Stevens peat area No. 1

Lake Stevens peat area No. 1 (82 acres) is in secs. 8 and 17, T. 29 N., R. 6 E., about 5 miles east of Everett. It is about 1½ miles long north and south, but its maximum width is only about 800 feet, and the northern part is less than 400 feet wide (map, fig. 186). The elevation of the surface of the lake (Marysville quadrangle) is 210 feet, and the one arm of the peat, as mapped on the soil map of Snohomish County, extends to the lake shore. The elevation of the peat is less than 225 feet above sea level, but there is higher land between the lake shore and the main body of the peat. The peat is accessible by several roads.

On the soil map of Snohomish County (Anderson et al., 1947) the area is mapped as Mukilteo peat. One hole (map, fig. 186) shows 5 feet of organic matter consisting of 1 foot of black muck, 1 foot of tan diatomite, 2 feet of dark brown muck, and 1 foot of brown fibrous peat in which layers of sand are present. The vegetation in the

vicinity of this hole is a dense growth of large alder trees with an undergrowth of brush.

Lake Stevens peat area No. 2

Lake Stevens peat area No. 2 (65 acres) is in secs. 20 and 21, T. 29 N., R. 6 E., about 1 mile south of area No. 1 (map, fig. 186). It is mapped (Anderson et al., 1947) as Mukilteo peat.

Digging along the road near the western end of the area revealed only 1 foot of muck resting on mineral soil. A hole in the swamp forest near the center of the area shows 20 feet of organic matter, under which is 1 foot of white marl resting on 6 inches of gray clay, under which is a mixture of sand and gravel (fig. 186). The upper 1 foot consists of the general debris of the forest floor. Un-

peat, shows an elevation of 387 feet above sea level. Iron Mountain, the summit of which is about a mile east of the peat, has an elevation of 1,085 feet. The South Fork Stillaguamish River is about a mile north of the town. It flows over granite at the falls about 2 miles northeast of the town, but the soils along the river directly north of the town are mapped in the soil survey of Snohomish County (Anderson et al., 1947) as rough mountainous land whose soils are developed mainly in place from hard metamorphic rocks. The Pilchuck River is less than a mile southwest of the town, and there is drainage to it from the vicinity of the peat but not directly from the peat area. The soils bordering the peat are stony and sandy. The road shown on the map (fig. 187) is corduroyed where it crosses the peat area.

On the soil map of Snohomish County the northern and central parts of the peat area are mapped as Greenwood peat, and the southern part as Rifle peat.

The map shows the location of the profile bored by Rigg and Richardson (1938), and also of three holes bored in 1949 and 1951 during the course of the field work on which the present bulletin is based. The map is based on the soil survey (Anderson et al., 1947), while the 1938 profile covers the sphagnum area only, hence the former is wider than the latter. The profile and hole A are in the sphagnum bog, on which the usual bog shrubs and herbaceous plants grow with *Sphagnum* moss and *Hypnum* moss among them. The trees are relatively small hemlock and spruce with some Douglas fir. Hole B is near a small commercial cranberry bog, and hole C is in that bog.

Figure 187 shows the materials found in the profile (Rigg and Richardson, 1938) and holes A, B, and C. The material shown as lake mud in the profile would probably be called sedimentary peat if the criteria used in later years had been used in 1938. The sphagnum in the profile is graded on the von Post scale mentioned in chapter II (p. 5). In hole A it is raw at the top of the layer and disintegrated at the bottom. In holes B and C it is decomposed. The sedimentary peat in holes A, B, and C varies from light olive to light brown. In hole A white pumicite forms a layer half an inch thick. The clay at the bottom of holes A and B is bluish gray. The gravel at the bottom of hole C is fine.

Hansen (1947) shows 8.0 meters (26 feet 3 inches) of materials in his sedimentary column in this peat. This includes 2.5 meters (8 feet 2 inches) of fibrous peat, 4.75 meters (15 feet 7 inches) of limnic (sedimentary) peat, 0.25 meter (10 inches) of silt, and 0.25 meter of sand. He found volcanic ash (pumicite) at a depth of 5.3 meters (17 feet 4 inches). A comparison of these data with the thickness of the layers of materials shown in hole 1 (fig. 187) indicates a general similarity except that he shows the upper layer as fibrous peat, while hole 1 shows it as sphagnum.

A quarter-acre patch of commercial cranberries owned by L. J. Bogart was planted in the Granite Falls peat area in 1947, using vines obtained from a grower near Grayland, Pacific County. Some berries have been produced and sold locally. No facilities for irrigation or flooding are provided, and the bog is dry in summer.

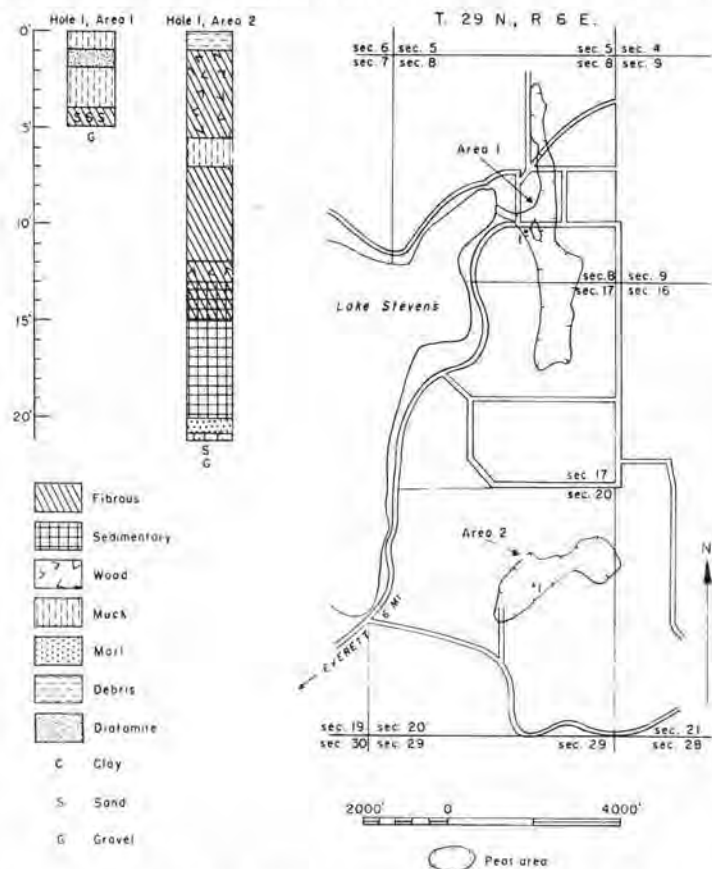

FIGURE 186.—Map and graphic logs of two holes in Lake Stevens peat areas (82 acres and 65 acres). Map adapted from U. S. Department of Agriculture soil map of Snohomish County and U. S. Army Map Service photomosaic.

der this is 4½ feet of brown fibrous decomposed peat with which some woody peat is mixed. Under this is a 1½-foot layer of black muck. Next is a 5-foot layer of brown fibrous peat which is mostly decomposed. The sedimentary peat is olive green.

Granite Falls peat area

The Granite Falls peat area (42 acres) is in sec. 18, T. 30 N., R. 7 E., adjoining the eastern border of the town of Granite Falls. The topography of the region is shown on the Stillaguamish quadrangle. The benchmark at the town, which is not more than 10 feet higher than the

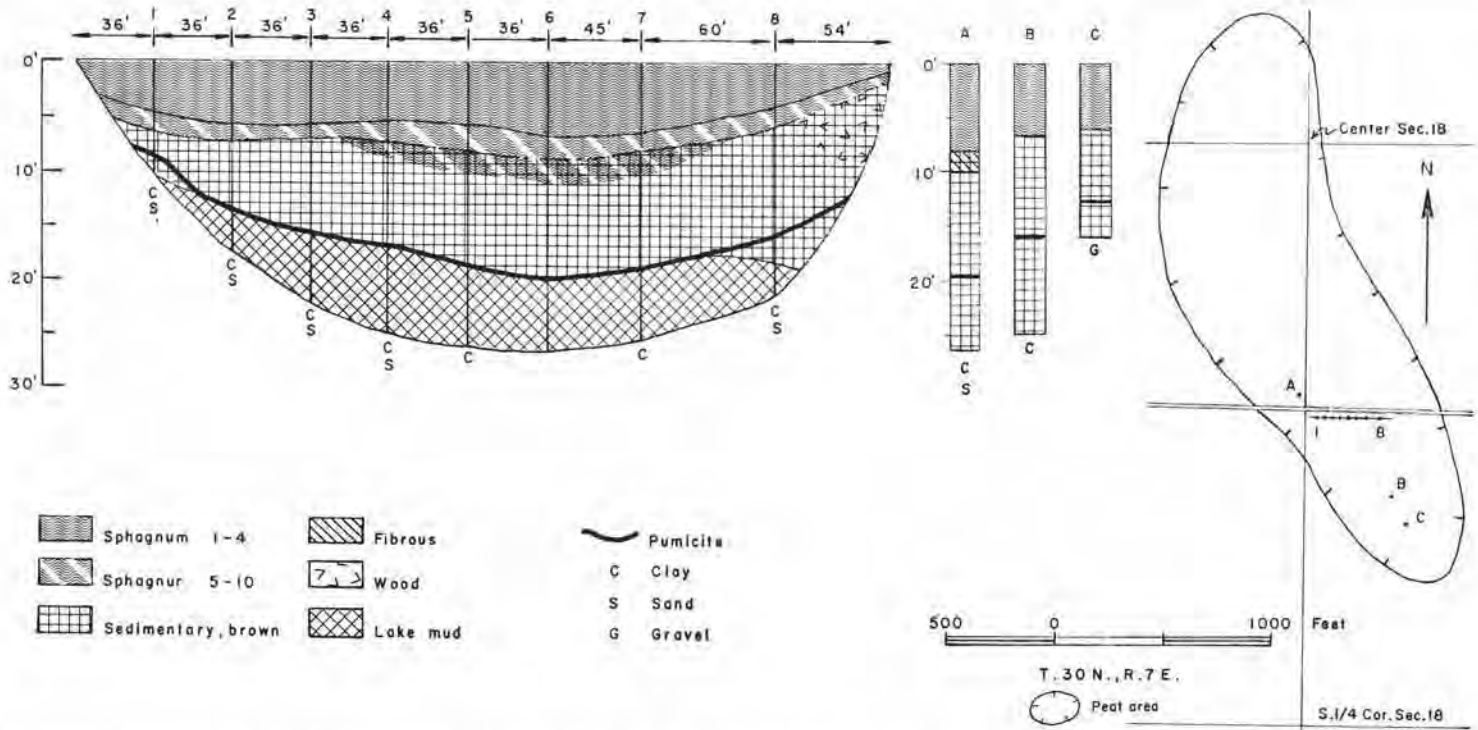

FIGURE 187.—Map, profile, and graphic logs of three holes in Granite Falls peat area (42 acres). Map adapted from U. S. Department of Agriculture soil map of Snohomish County and U. S. Army Map Service photomosaic.

Lake Ballinger peat area

The Lake Ballinger peat area (41 acres) is in sec. 32, T. 27 N., R. 4 E., about 3 miles southeast of Edmonds. It borders the north shore of the lake (map, fig. 188). A small stream flows across the peat to the lake, and another one (McAleer Creek) flows from the lake to Lake Washington. On the Snohomish quadrangle the lake now known as Ballinger is called McAleer. The elevation of the peat is about 280 feet above sea level.

On the soil map of Snohomish County (Anderson et al., 1947) the peat area is mapped as Mukilteo peat with a small area of Carbondale muck, shallow phase, in the northwestern part. The profile (1,250 feet long) extends from west to east along an old road 150 feet north of the north shore of the lake. At the west end of the profile the land slopes steeply up 50 feet or more. On the east the profile ends at an alluvial fan which extends 300

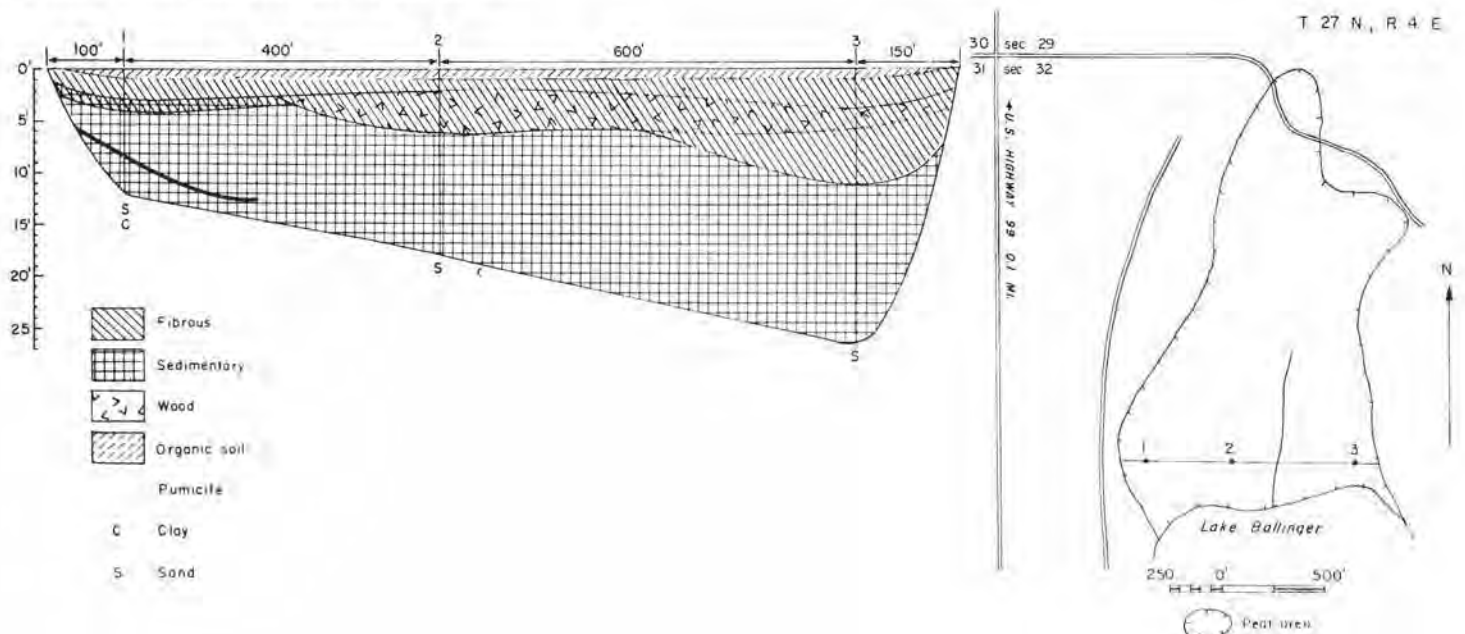

FIGURE 188.—Map and profile of Lake Ballinger peat area (41 acres). Map adapted from U. S. Army Map Service photomosaic.

or 400 feet into the valley, and there may be some peat under this fan.

The line of the profile is in a pasture. In summer the peat surface near this line is dry near its margins but is wet in the center. The vegetation near the margins consists of pasture grasses, hardhack, and weeds. In the center, skunk cabbage, reeds, and mint occur with the grasses and hardhack. It seems probable that the level of the lake was lowered somewhat several years ago.

The materials found in the profile (fig. 188) are organic soil, fibrous peat, woody peat, and sedimentary peat. The peat soil is brown to dark brown and is rather strongly acidic (pH 4.7). The fibrous peat is brown to dark brown. Some of it is raw and coarse, but most of it is disintegrated. The sedimentary peat is olive to olive brown and is weakly acidic (pH 5.0). Pumicite was found in hole 1 only. It is white and forms a layer half an inch thick. The deposit rests on gray sand, which is mixed with clay at the bottom of hole 1.

Riley Lake peat area

The Riley Lake peat area (38 acres) is in secs. 19 and 20, T. 32 N., R. 7 E., about 13 miles by road northeast of Arlington. The road extends along the Skagit power line of the Seattle city light system and crosses the southern part of the peat. The peat entirely surrounds the lake (map, fig. 189). The elevation of the lake (525 feet) and the topography of the region are shown on the

Stillaguamish quadrangle. There is some drainage from the lake to the Stillaguamish River through Jim Creek and a tributary. The lake and the peat occupy a depression formed through glacial or glaciofluvial agencies in Pleistocene time.

The area is mapped as Greenwood peat on the soil map of Snohomish County (Anderson et al., 1947). Profile A begins at the southeast end of the lake in a sphagnum bog and extends 400 feet southeast to the margin of an open forest of cedar and hemlock.

The sphagnum peat, fibrous peat, woody peat, peat slime, and sedimentary peat in the profile form a complicated pattern (fig. 189). The sphagnum at the surface is dark brown and disintegrated. The 2-foot layer of sphagnum beginning at the 4-foot depth in hole 1 is dark brown, decomposed, and watery. The peat slime above it contains some remains of sphagnum. The fibrous peat, whether alone or mixed with woody peat, is brown to dark brown and is disintegrated to decomposed. The sedimentary peat is olive green. The layer of pumicite in hole 1 is white and is 1/4 inch thick; in hole 3 it is brown and 1/2 inch thick. The deposit rests on fine gray sand.

Profile B extends 400 feet northeast from the northeast shore of the lake. The vegetation at hole 1 consists of Labrador tea, hardhack, beak rush, mint, and sundew. The only trees on this part of the bog are a few scattered hemlocks, mostly 1 to 4 feet tall, but a few are 6 to 30 feet tall. At hole 2 the vegetation consists of Labrador tea,

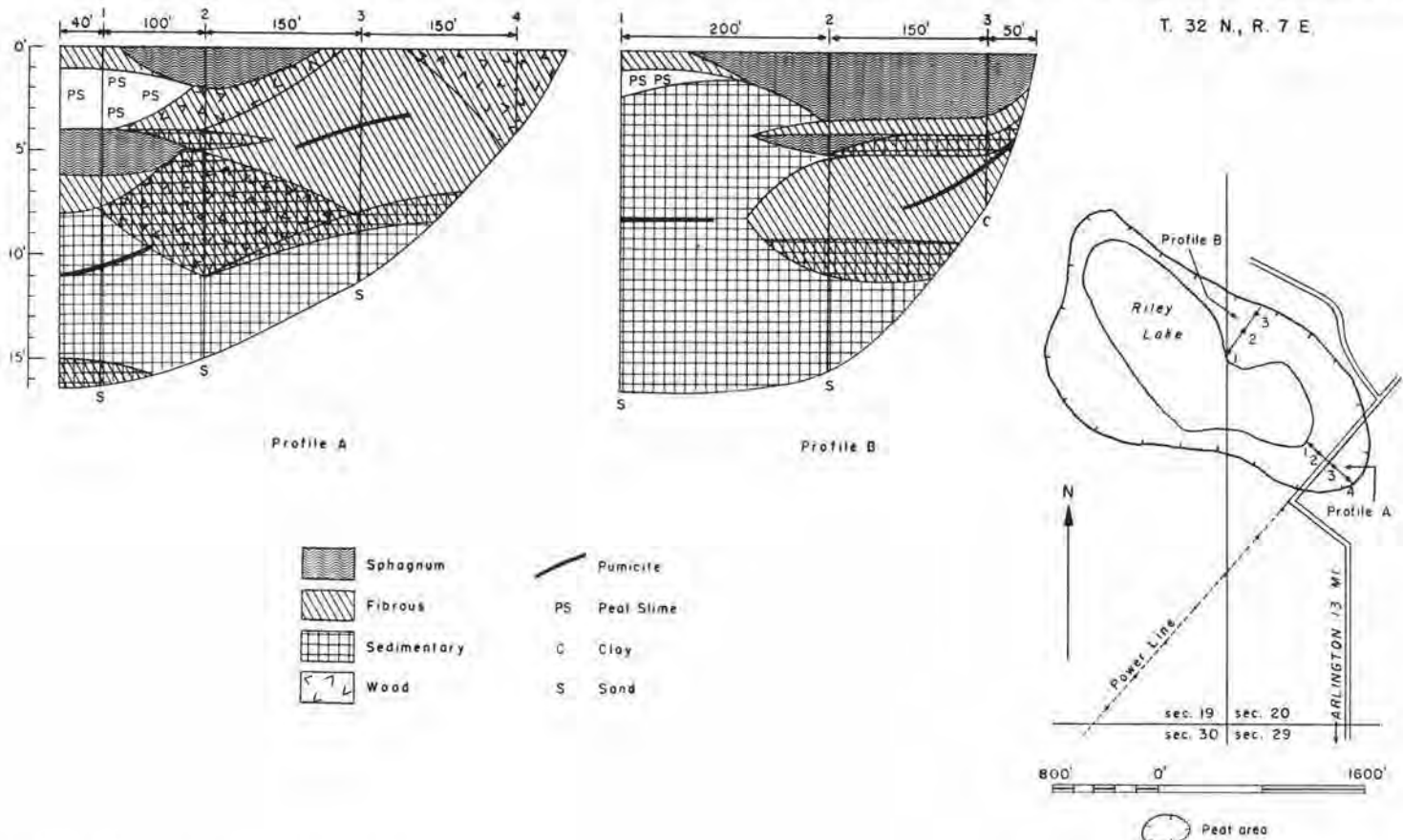

FIGURE 189.—Map and profiles of Riley Lake peat area (38 acres). Map adapted from U. S. Department of Agriculture soil map of Snohomish County and U. S. Army Map Service photomosaic.

bog laurel, salal, and bracken fern. At hole 3 the only vegetation is a dense growth of tall bracken fern. The surface at the end of the profile is bedrock.

The characteristics of the materials in profile B are not essentially different from those of the materials in profile A. In hole 3 the sphagnum peat and the sedimentary peat are strongly acidic (pH 4.0).

The owner stated that the part of the bog now covered with bracken fern was plowed some years ago and a crop of oats was grown on it. A small vegetable garden now occupies part of it. Beets and carrots were growing well there in July 1951, but peas were not doing well.

Hooven peat area

The Hooven peat area (20 acres) is in secs. 35 and 36, T. 27 N., R. 5 E. (map, fig. 190), about a mile west of the Crystal Lake-Little Lake peat area and about 3 miles by road northeast of Woodinville. The peat lies in a depression in glacial drift. The location of the small lake which it encircles and its relation to the topography of the surrounding region are shown on the Everett quadrangle. The elevation of the lake is between 375 and 400 feet above sea level. A stream flows from the lake to the Crystal Lake-Little Lake peat area. On the soil map of Snohomish County (Anderson et al., 1947) the area is mapped as Greenwood peat.

This is a typical sphagnum bog with a natural "marginal ditch" surrounding it. It was inspected by Rigg in 1929,

and the changes in it since that date have been very slight. It has the usual vegetation of bog shrubs and herbaceous species. Living *Sphagnum* is abundant. Hemlock is the most abundant tree in some parts of the bog, and lodgepole pine in others. Cedar also occurs, and white pine is occasional. Many aquatic species grow in the margin of the lake, and the usual transition species from lake to the wet margin of the bog are abundant. The growth of hardhack in the "marginal ditch" is dense, and some cascara trees grow with it.

Profile A (fig. 190) was published by Rigg and Richardson (1938). The material shown in this profile as lake mud would be called sedimentary peat if the criteria now used had been used then. The sphagnum is classified on the von Post scale mentioned in chapter II (p. 5).

Profile B was bored in 1951. Hole 1 is in a dense growth of hardhack in the "marginal ditch." Holes 2 and 3 are in the sphagnum bog in which lodgepole pine trees are abundant and hemlock trees are scarce. The shrubs at hole 4 are hardhack and Labrador tea.

The materials shown in the profile are sphagnum peat, fibrous peat, woody peat, and sedimentary peat. Some peat slime is present. The sphagnum is brown. It is raw at the top of the layer and is moderately disintegrated at the bottom. The fibrous peat is dark brown and decomposed. The sedimentary peat is olive to olive brown. In holes 2, 3, and 4 it is too compact to be penetrated below

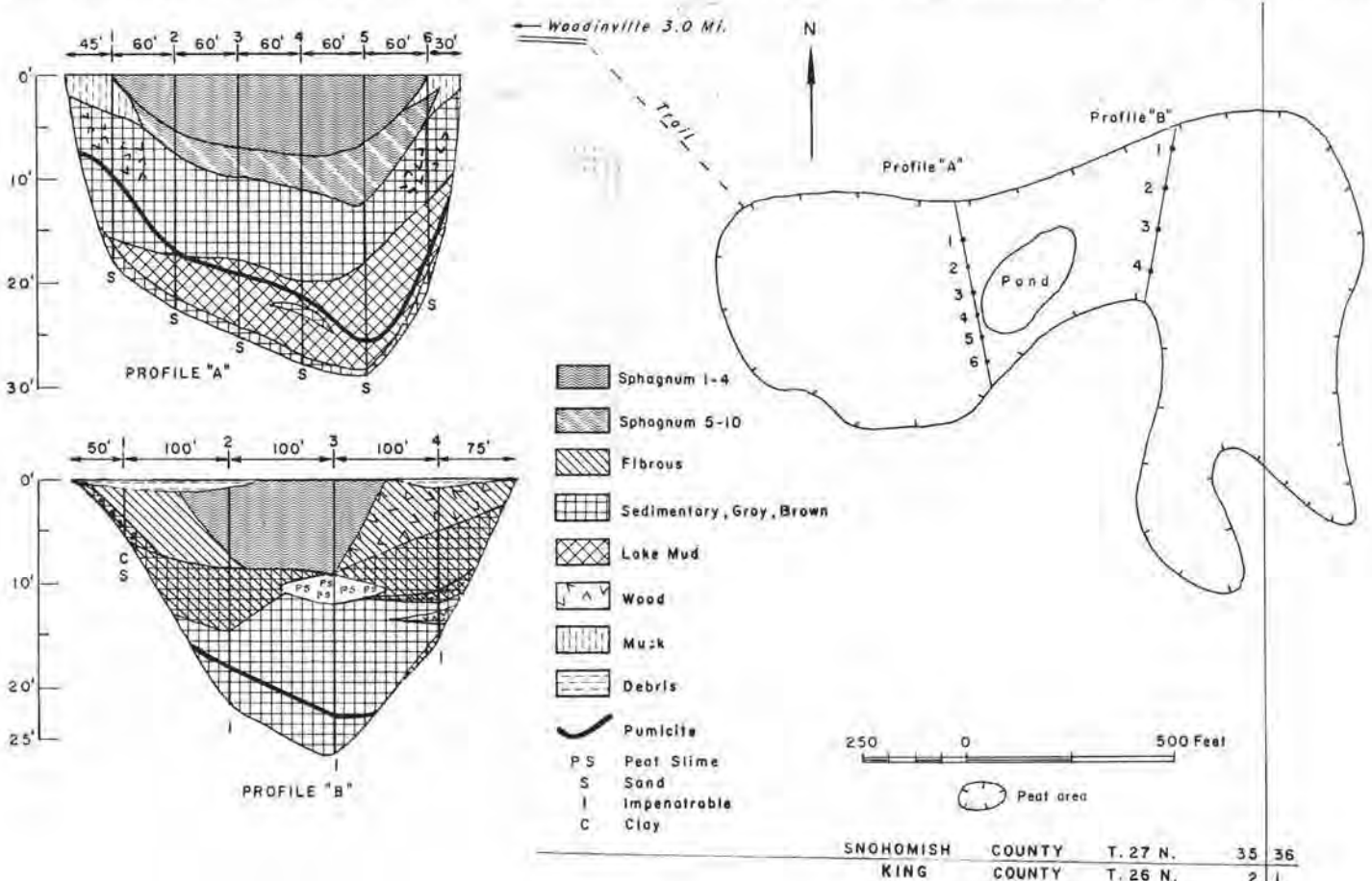

FIGURE 190.—Map and profiles of Hooven peat area (20 acres). Map adapted from U. S. Department of Agriculture soil map of Snohomish County, U. S. Army Map Service photomosaic, and Rigg and Richardson (1938).



FIGURE 191.—The late Dr. A. P. Dachnowski-Stokes at work in Hooven sphagnum bog, about 1930.

the depth shown in figure 190. The layer of pumicite is 1 inch thick. It is tan in hole 2 and light gray in hole 3.

Dachnowski-Stokes (1930) found a maximum depth of 28 feet of peat in this bog. He reports that the sphagnum moss peat is relatively pure, is reddish to yellowish

brown, and is poorly decomposed, and that the sedimentary peat contains numerous diatoms.

Scriber Lake peat area

The Scriber Lake peat area (estimated 20 acres) is in secs. 16 and 21, T. 27 N., R. 4 E., about ¼ mile east of Lynnwood and about 3 miles east of Edmonds. It borders the east, north, and west shores of the lake. The lake and the topography of the surrounding region are shown on the Edmonds quadrangle. The elevation of the lake and the peat is approximately 350 feet above sea level. The slopes bordering the peat are gentle, but the slope from the south side of the lake is steeper. The lake and the peat lie in a depression in the glacial drift of the region. A stream with a strong current flows from the eastern end of the lake, and the water eventually reaches Lake Washington. On the soil map of Snohomish County (Anderson et al., 1947) the area is mapped as Carbondale muck.

A sphagnum bog, whose area is estimated to be 1½ acres, borders the west end of the lake, and a smaller one borders the east end. A sketch map of the lake and these bogs and a profile of each of the bogs was published by Rigg and Richardson (1938), and the peat area has been inspected by Rigg several times since then, the last visit being April 3, 1953. The vegetation on the bogs includes Labrador tea, bog laurel, and cranberry. *Sphagnum* moss is still growing among the shrubs.

The bog at the west end of the lake and the brushy area bordering it have been considerably changed by the establishment of a resort there. Peat has been recently removed and marketed from the area just south of the road east of the lake.

The sketch map and the profiles (fig. 192) are redrawn from those published by Rigg and Richardson (1938). The degree of disintegration of the sphagnum in these profiles is graded on the von Post scale mentioned in chapter II (p. 5). The lake mud shown in the profiles would be called sedimentary peat if the criteria used later had been applied. It will be noted that the layer of pumicite is entirely in this material.

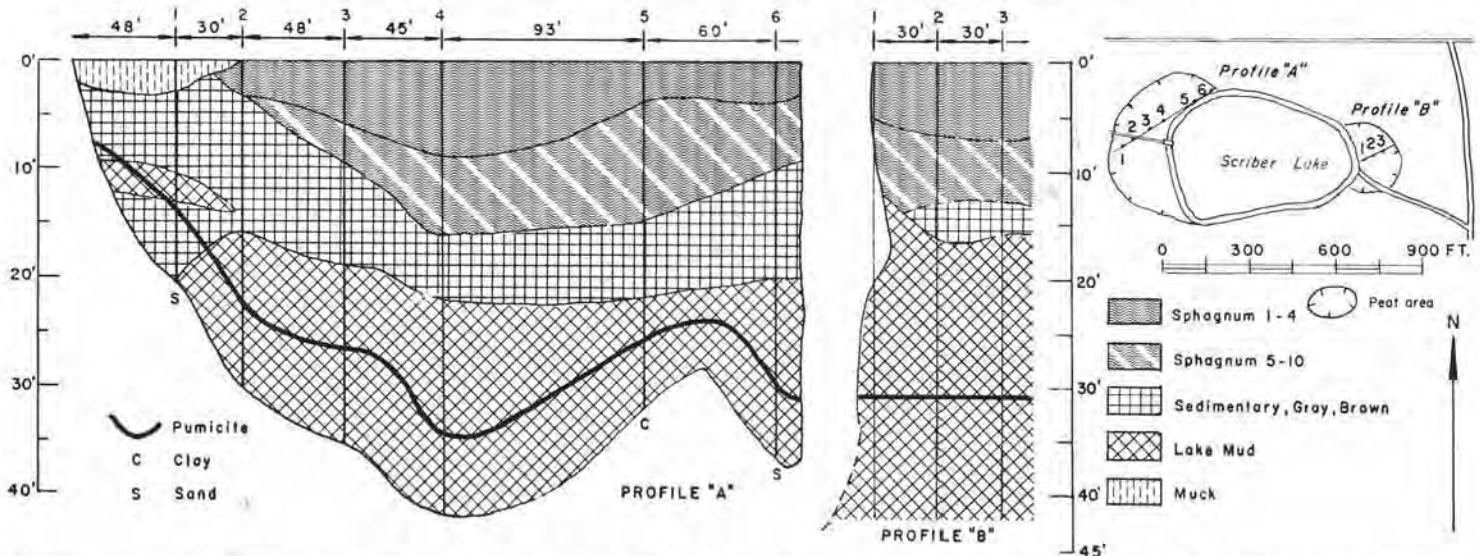

FIGURE 192.—Map and profiles of Scriber Lake peat area (20 acres, estimated). Map adapted from Rigg and Richardson (1938).